

FOREWORD

UNIFORM STANDARD DRAWINGS FOR PUBLIC WORKS' CONSTRUCTION, OFFSITE IMPROVEMENTS, CLARK COUNTY AREA, NEVADA VOLUME II

The following participating entities of the Clark County, Nevada area have adopted these standard drawings.

CITY OF LAS VEGAS	
Adopted by City Council action	November 4, 1987
CITY OF HENDERSON	
Adopted by City Council action	October 20, 1987
CITY OF NORTH LAS VEGAS	
Adopted by City Council action	November 4, 1987
CITY OF BOULDER CITY	
Adopted by City Council action	January 26, 1988
CITY OF MESQUITE	
Adopted by City Council action	January 26, 1988
CLARK COUNTY	
Adopted by Board action	April 1998
REGIONAL STREET AND HIGHWAY COMMISSION	
Adopted by Commission Action	October 8, 1987

The Uniform Standard Drawings for Public Works Construction may be revised by issuance of revisions or supplements to correct errors and omissions found in these drawings and to reflect advanced thinking and the changing technology of the construction industry. Each revision will supersede any previous pertinent drawing. Upon approval by the RTC, revisions will become effective and be posted on the RTC web-site, www.rtcsonthernnevada.com, by the first day of the month of January and July.

To implement this end a Specifications Committee has been established as a permanent organization to continually study and recommend changes to the standard drawings. Interested parties may address suggested changes and questions to the Regional Transportation Commission, 600 South Grand Central Parkway, Suite 350, Las Vegas, Nevada, 89106-4512.

PROPOSED EXISTING



PULL BOX



SIGNAL LUMINAIRE POLE, POST



UTILITY POLE



CONTROL CABINET

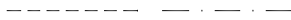

CONDUIT RUN



AERIAL CABLE



DETECTOR LOOP



PADMOUNT, ELECTRICAL SERVICE OR SPLICE BOX



FLUORESCENT LUMINAIRE



HIGH PRESSURE
SODIUM LUMINAIRE - 750 WATT



HIGH PRESSURE
SODIUM LUMINAIRE - 400 WATT

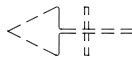

TRAFFIC SIGNAL INDICATION WITH BACKPLATE

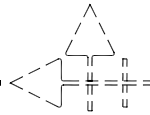
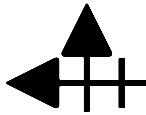

TRAFFIC SIGNAL INDICATION WITH DIRECTIONAL
ARROW AND BACKPLATE



PEDESTRIAN INDICATION AND DIRECTION



HAZARD BEACON, ONE WAY

SPECIFICATION REFERENCE

UNIFORM STANDARD DRAWINGS
CLARK COUNTY AREA

STANDARD SYMBOLS FOR
TRAFFIC SIGNAL DRAWINGS

DATE 12-12-96

DWG. NO. 404.001

SHEET 1 OF 2

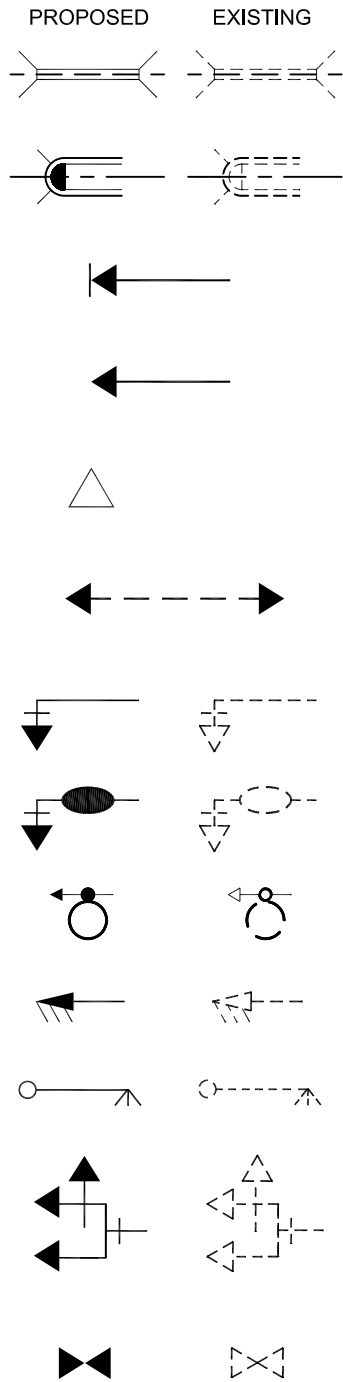

STREET NAME SIGN
INTERNALLY ILLUMINATED

CURB FLASHER

VEHICLE MOVEMENT (STOPPED)

VEHICLE MOVEMENT (MOVING)

CONDUIT RUN NUMBER

PEDESTRIAN MOVEMENT

TRAFFIC SIGNAL ON MAST ARM

TRAFFIC SIGNAL AND LUMINAIRE
ON MAST ARMS

PEDESTRIAN PUSH BUTTON
INDICATING DIRECTION OF CONTROL

TRAFFIC SIGNAL WITH
ALL COLORS LOUVERED

SCHOOL FLASHER

5 SECTION SIGNAL HEAD WITH DIRECTIONAL
ARROW AND BACKPLATE

PRIORITY VEHICLE PREEMPTION OPTICAL DETECTOR
(OPTICOM OR APPROVED EQUAL)

SPECIFICATION REFERENCE

UNIFORM STANDARD DRAWINGS
CLARK COUNTY AREA

STANDARD SYMBOLS FOR
TRAFFIC SIGNAL DRAWINGS

DATE 12-12-96

DWG. NO. 404.001

SHEET 2 OF 2

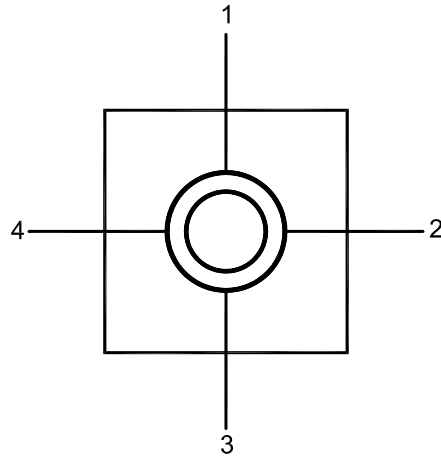

QUADRANT
 ARM OR SIGNAL LOCATION
 (TOP VIEW)

NOTE: QUADRANT IS IN RELATION WITH SHEET - NOT WITH NORTH ARROW

SPECIFICATION REFERENCE

UNIFORM STANDARD DRAWINGS
 CLARK COUNTY AREA

QUADRANT DETAIL

DATE

DWG. NO. 404.002

SHEET 1 OF 1

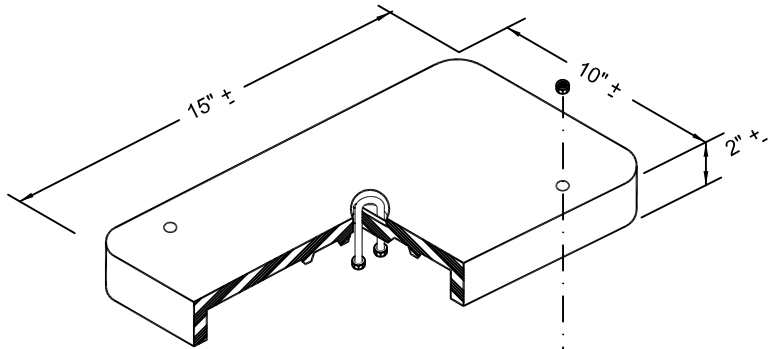

CAST IRON SIDEWALK COVER
MARKED "TRAFFIC SIGNAL"

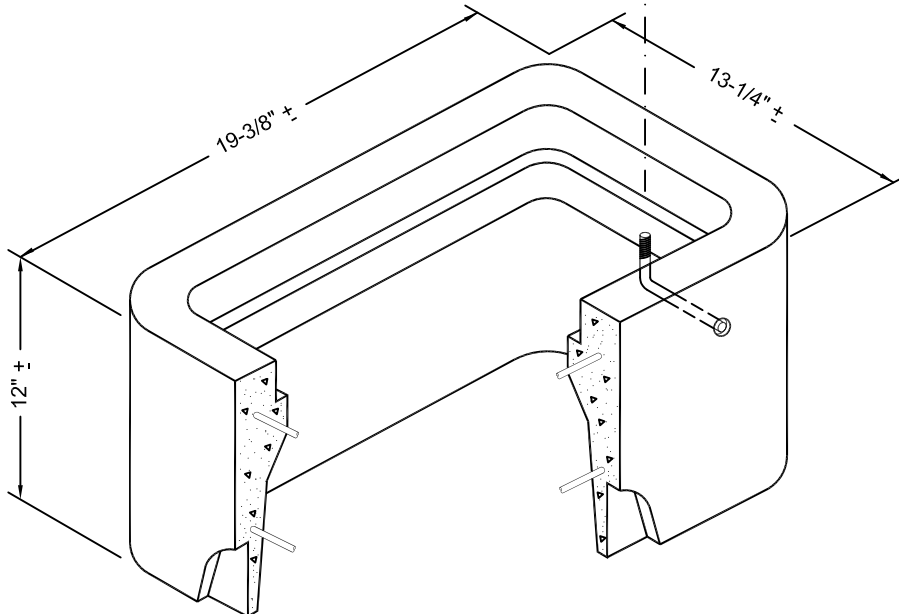

PRECAST REINFORCED
CONCRETE BODY

NOTES:

1. THIS PULL BOX SHALL NOT BE USED IN TRAFFIC OR PARKING LANES.
2. ALL DIMENSIONS ARE NOMINAL.

Effective 01/01/09 - 06/30/09

SPECIFICATION REFERENCE	UNIFORM STANDARD DRAWINGS CLARK COUNTY AREA		
	NO. 3-1/2 PULL BOX		
	DATE	DWG. NO. 404.110	SHEET 1 OF 1

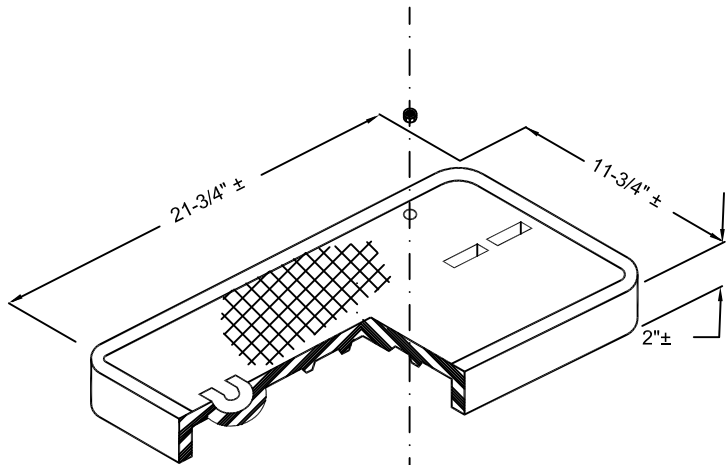

CAST IRON SIDEWALK COVER
MARKED "TRAFFIC SIGNAL"

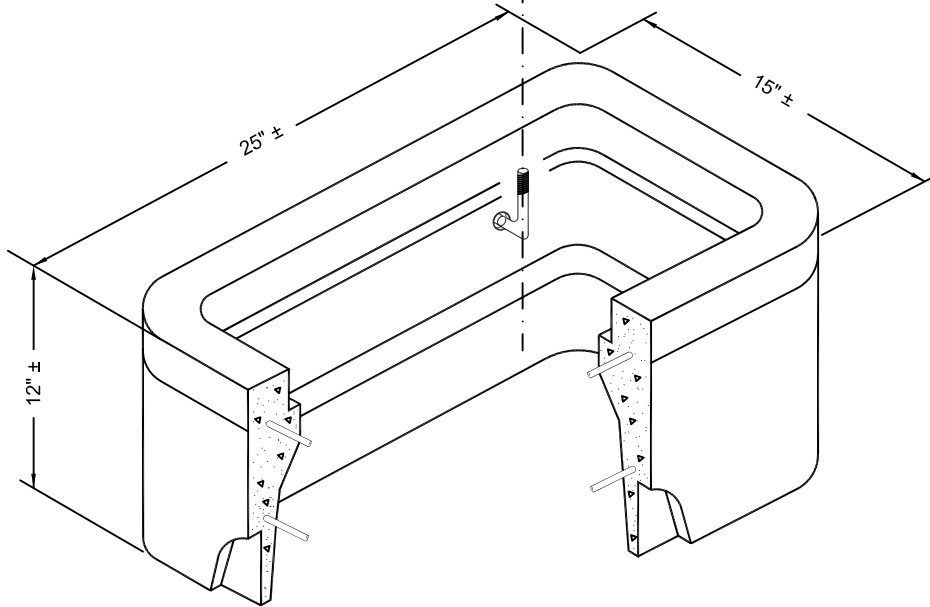

PRECAST REINFORCED
CONCRETE BODY

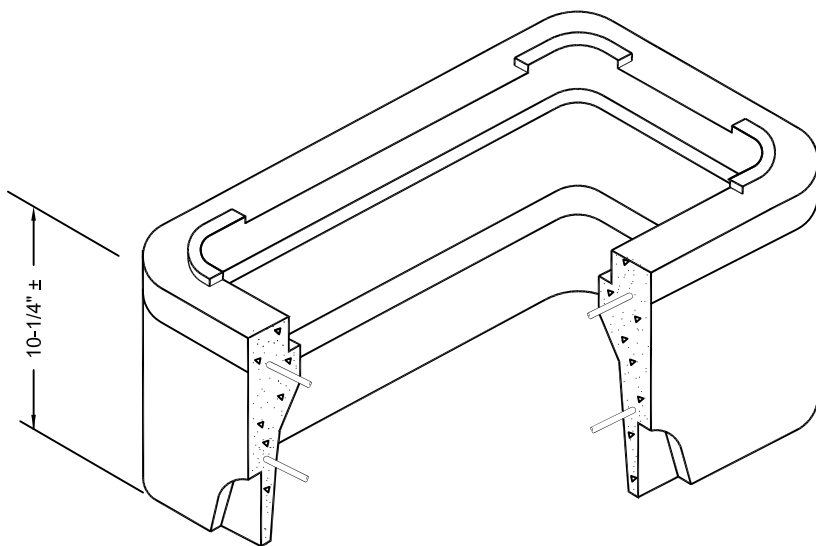

PRECAST REINFORCED CONCRETE
EXTENSION. (MUST NOT BE
USED UNLESS SPECIFIED.)

NOTES:

1. CAST IRON COVER SHALL BE USED IN SIDEWALK ONLY.
2. SEE DRAWING NO. 404.140 FOR COVER TO BE USED IN STREET AND UNDEVELOPED AREAS.
3. ALL DIMENSIONS ARE NOMINAL.

SPECIFICATION REFERENCE

UNIFORM STANDARD DRAWINGS
CLARK COUNTY AREA

NO. 5 PULL BOX

DATE

DWG. NO. 404.120

SHEET 1 OF 1

PLASTIC MORTAR REINFORCED
SIDEWALK COVER MARKED
"TRAFFIC SIGNAL"

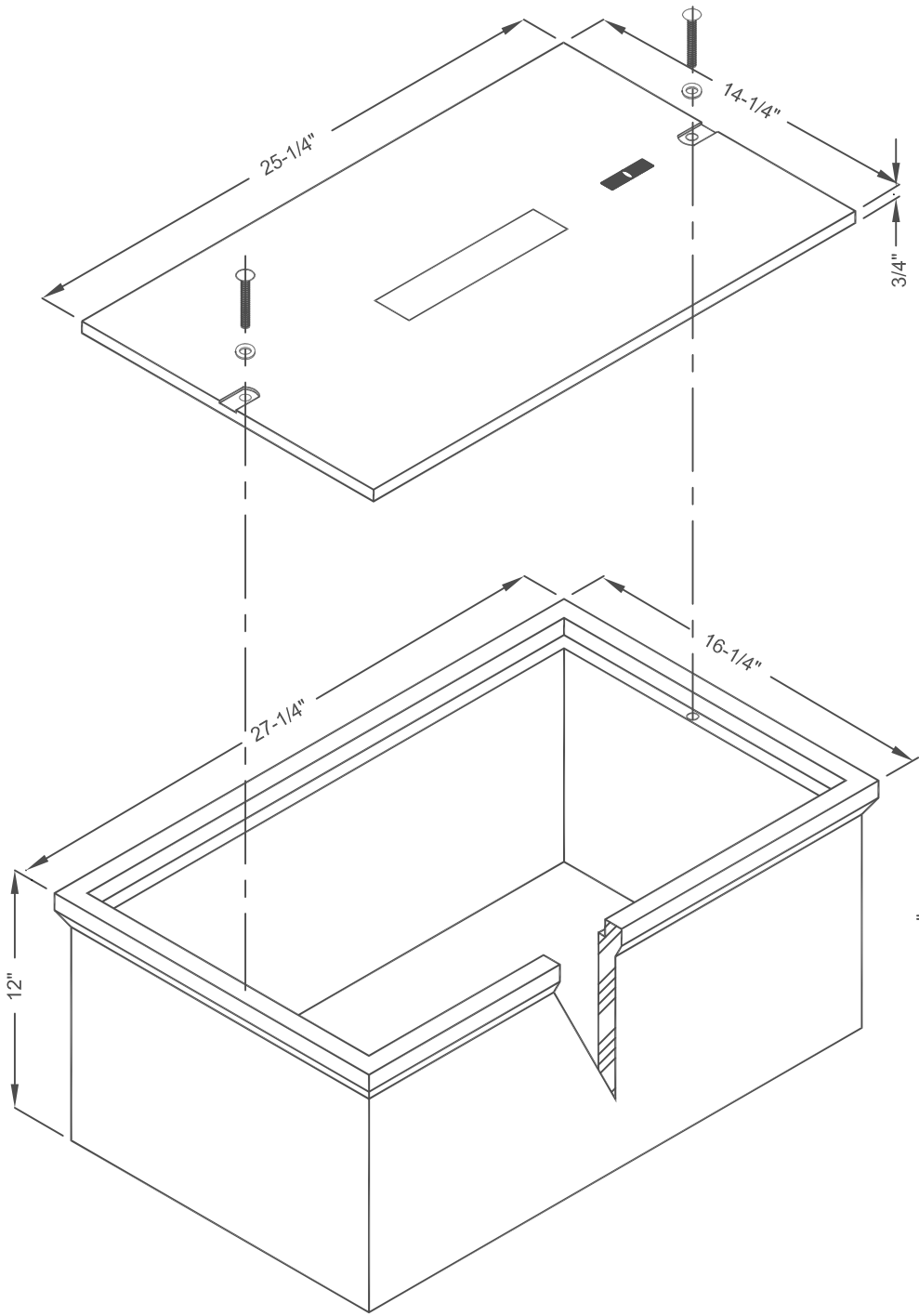

REINFORCED PLASTIC
MORTAR EXTENSION.

NOTES:

1. THIS PULL BOX SHALL NOT BE USED IN VEHICLE TRAVEL AREAS.
2. PULL BOX TO BE USED IN CONCRETE SIDEWALKS ONLY.

SPECIFICATION REFERENCE

UNIFORM STANDARD DRAWINGS
CLARK COUNTY AREA

REINFORCED PLASTIC MORTAR
SERVICE BOX ASSEMBLY #5

DATE

DWG. NO. 404.121

SHEET 1 OF 1

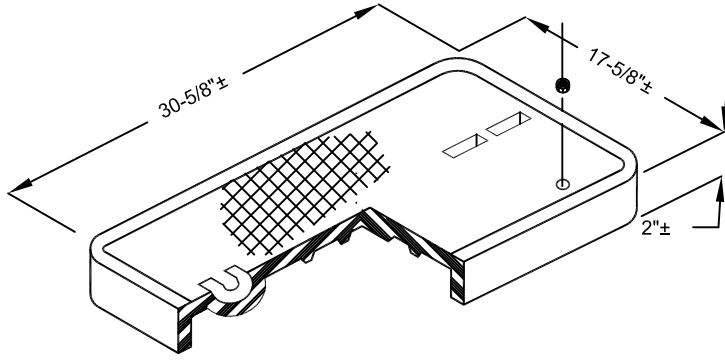

CAST IRON SIDEWALK COVER
 MARKED "TRAFFIC SIGNAL"
 STEEL PULL BOX COVER,
 DRAWING NO. 404.140 IS
 PREFERRED FOR ALL USES,
 THIS PULL BOX ONLY.

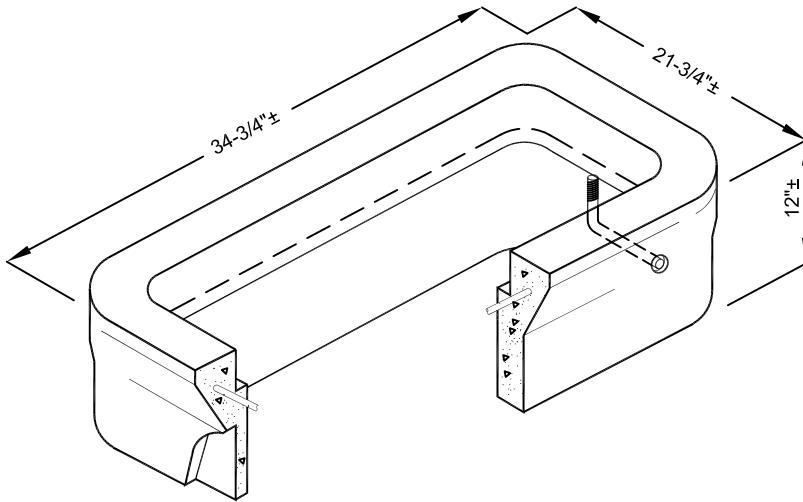

PRECAST REINFORCED
 CONCRETE BODY.

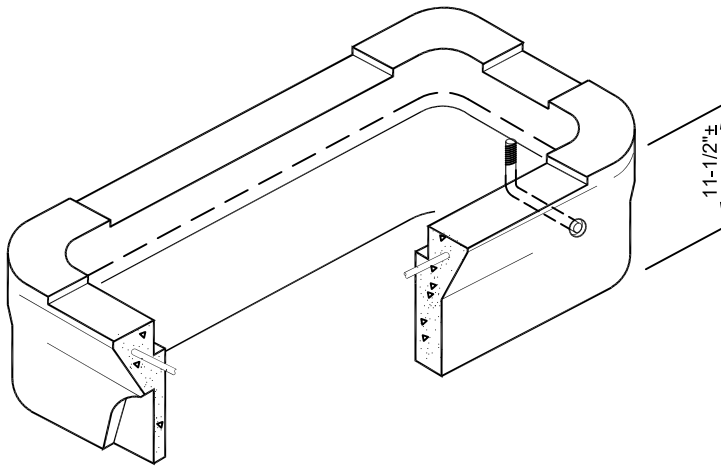

PRECAST REINFORCED CONCRETE
 EXTENSION. (MUST NOT BE
 USED UNLESS SPECIFIED.)

NOTES:

1. THIS PULL BOX SHALL NOT BE USED IN TRAFFIC OR PARKING LANES.
2. SEE DRAWING NO. 404.140 FOR ALTERNATE COVER.

SPECIFICATION REFERENCE

UNIFORM STANDARD DRAWINGS
 CLARK COUNTY AREA

NO. 7 PULL BOX

DATE

DWG. NO. 404.130

SHEET 1 OF 1

PLASTIC MORTAR REINFORCED
SIDEWALK COVER MARKED
"TRAFFIC SIGNAL"

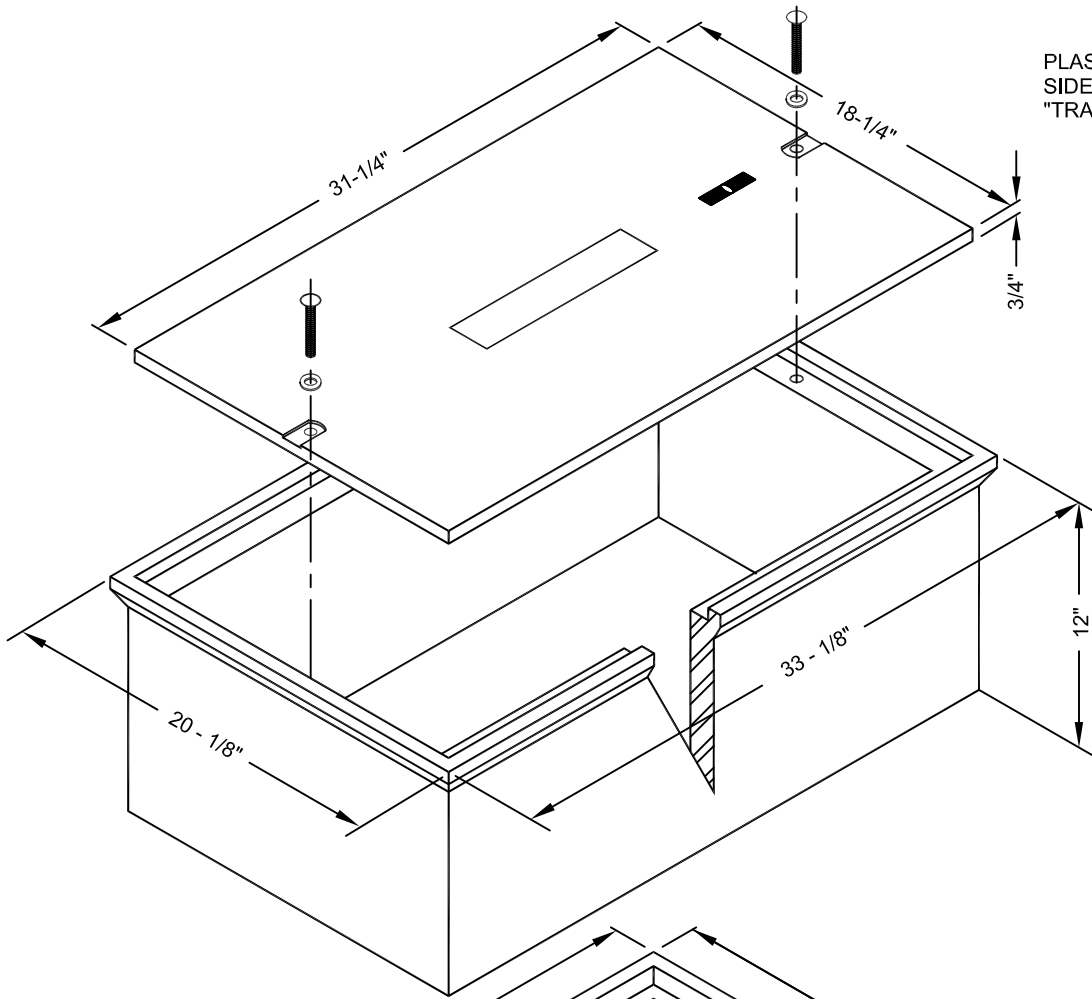

REINFORCED PLASTIC
MORTAR BODY.

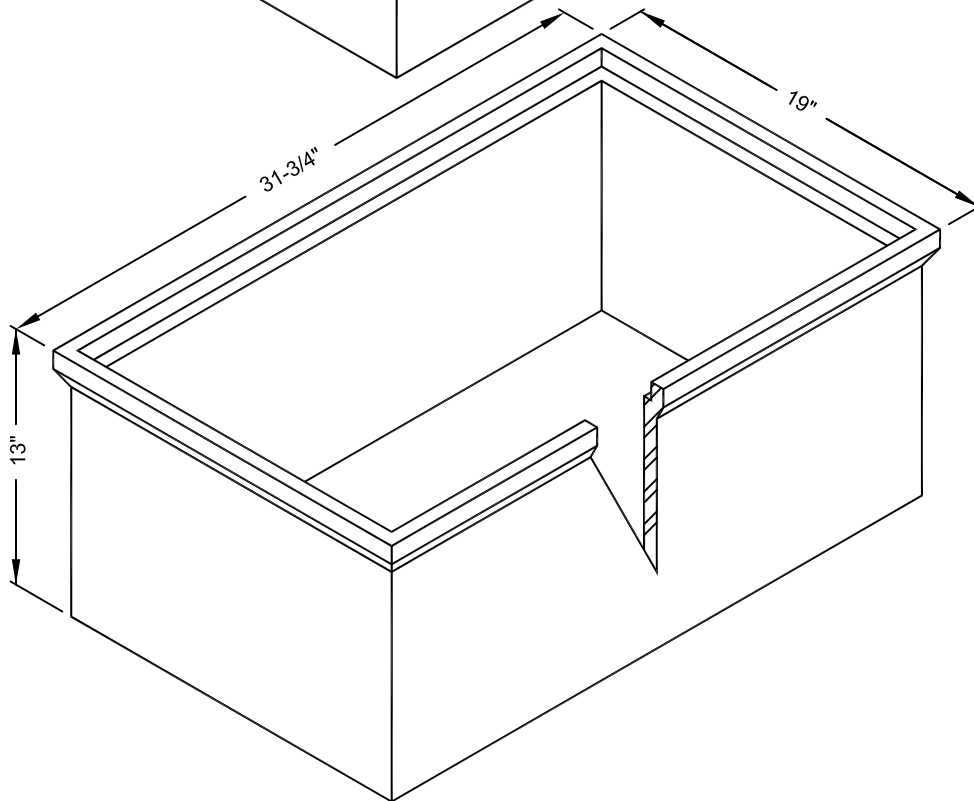

REINFORCED PLASTIC
MORTAR EXTENSION.

NOTES:

1. THIS PULL BOX SHALL NOT BE USED IN VEHICLE TRAVEL AREAS.
2. PULL BOX TO BE USED IN CONCRETE SIDEWALKS ONLY.

SPECIFICATION REFERENCE

UNIFORM STANDARD DRAWINGS
CLARK COUNTY AREA

REINFORCED PLASTIC MORTAR
SERVICE BOX ASSEMBLY #7

DATE

DWG. NO. 404.131

SHEET 1 OF 1

REINFORCED POLYMER
CONCRETE COVER
MARKED "FIBER OPTIC"

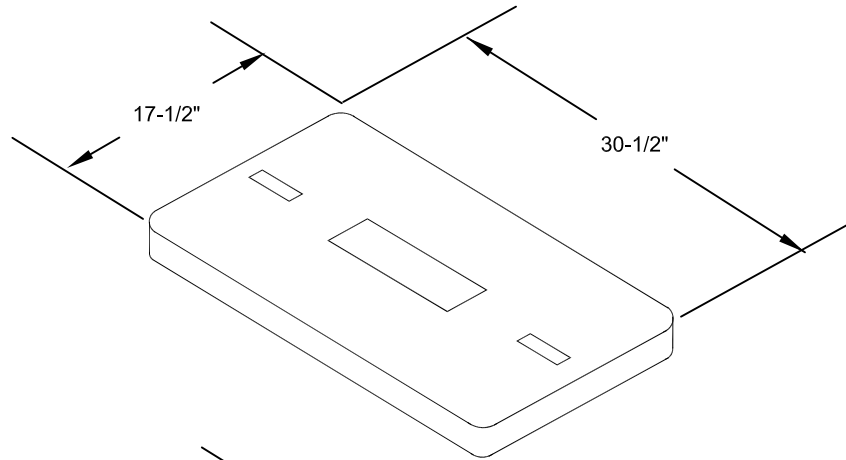

POLYMER COMPOSITE
BODY

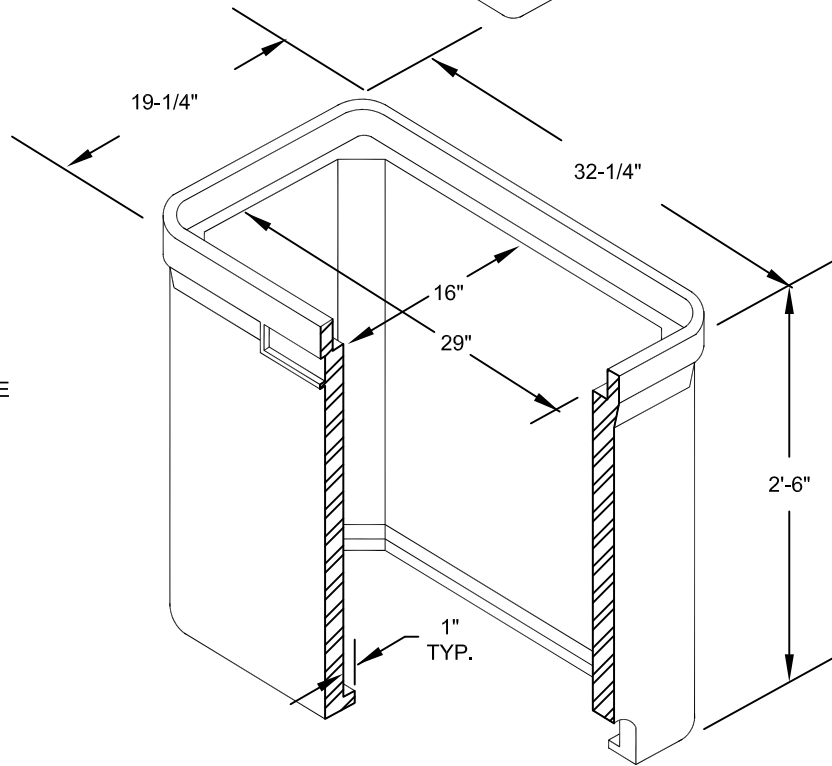

NOTES:

1. THIS PULL BOX SHALL NOT BE USED IN TRAVEL OR PARKING LANES.

SPECIFICATION REFERENCE

UNIFORM STANDARD DRAWINGS
CLARK COUNTY AREA

"P30" PULLBOX

(FOR USE IN INTERCONNECT AND
COMMUNICATIONS INSTALLATIONS)

DATE 3-13-03

DWG. NO.

404.132

SHEET 1 OF 1

ADJUSTABLE TORSION
 SPRING ASSISTED STEEL
 COVER MARKED "FIBER OPTIC"

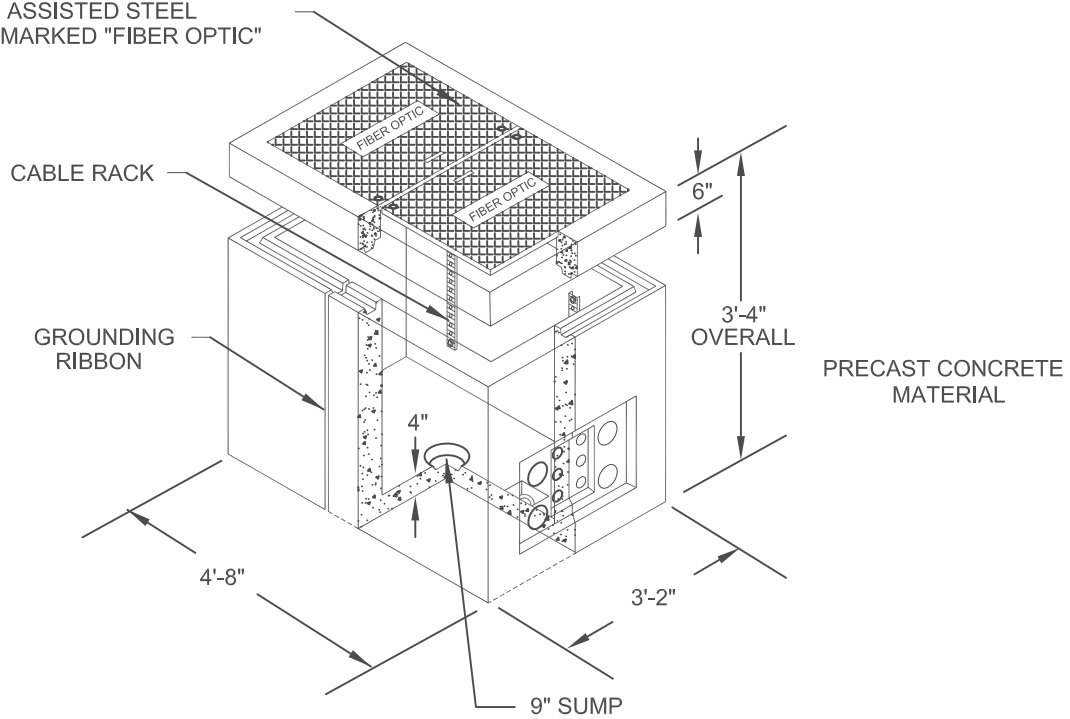

NOTES:

1. DESIGN LOAD: H-20 WHEEL LOADINGS.
2. SUITABLE FOR USE IN OFF STREET LOCATIONS WHERE NOT SUBJECT TO HIGH DENSITY TRAFFIC. IT SHALL NOT BE USED IN TRAVEL OR PARKING LANES.
3. INSIDE DIMENSIONS - 30"X48"X36"
4. FOR USE AT FIBER OPTIC SPLICE POINTS.

TYPE 200 VAULT

SPECIFICATION REFERENCE

UNIFORM STANDARD DRAWINGS
 CLARK COUNTY AREA

TYPE 200 VAULT
 (FOR USE AT FIBER OPTIC SPLICE POINTS)

DATE 3-13-08

DWG. NO. 404.133

SHEET 1 OF 1

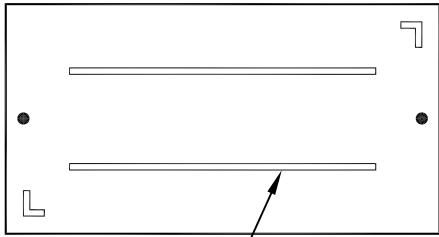

WELD PLATE STIFFENERS

BOTTOM VIEW

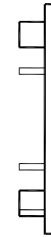

SIDE VIEW

BEAD WELD INSCRIPTION

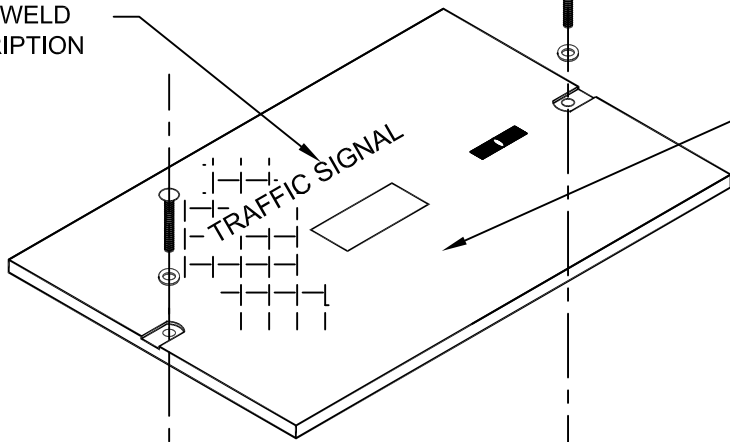

3/8" DIAMOND PLATE

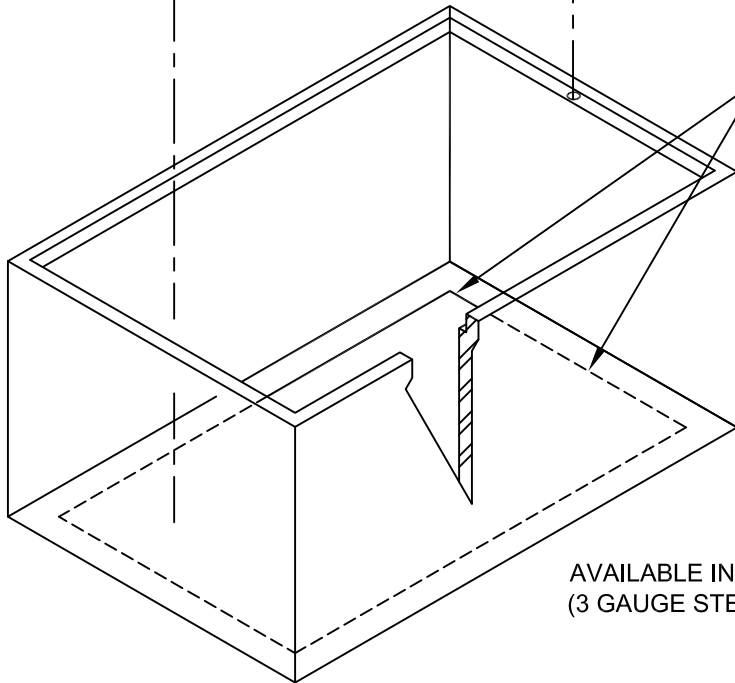

2" LIP AROUND INSIDE OF PULL BOX

NOTE:

1. THIS PULL BOX SHALL BE USED IN VEHICLE TRAVEL AREAS.

AVAILABLE IN #3, #5, & #7 SIZES
(3 GAUGE STEEL)

SPECIFICATION REFERENCE

UNIFORM STANDARD DRAWINGS
CLARK COUNTY AREA

STEEL PULL BOXES

DATE

DWG. NO.

404.139

SHEET

1 OF 1

ACCESS HOLE TO PULL BOX "L" BOLTS

BEAD WELD INSCRIPTION

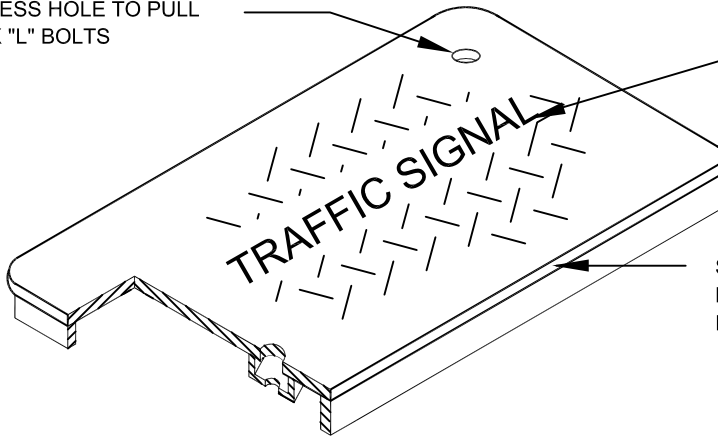

STEEL FLOOR PLATE, 3/8" THICK, ROUND CORNERS TO MATCH EDGES OF PULL BOX

COVER

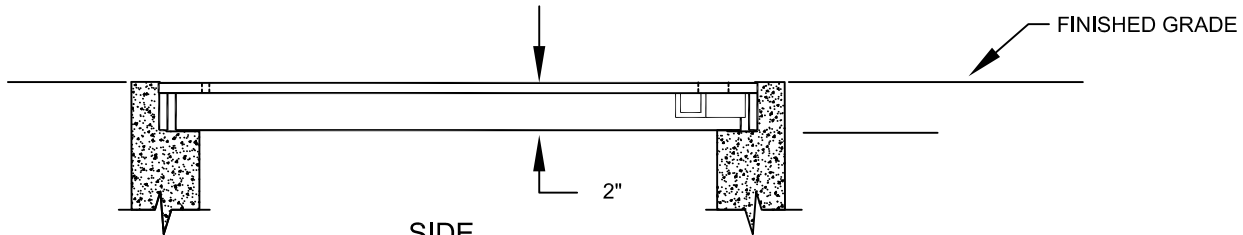

SIDE

MOUNTING BRACKET, WELDED TO COVER, TYP. LOCATE TO MATCH PULL BOX "L" BOLTS

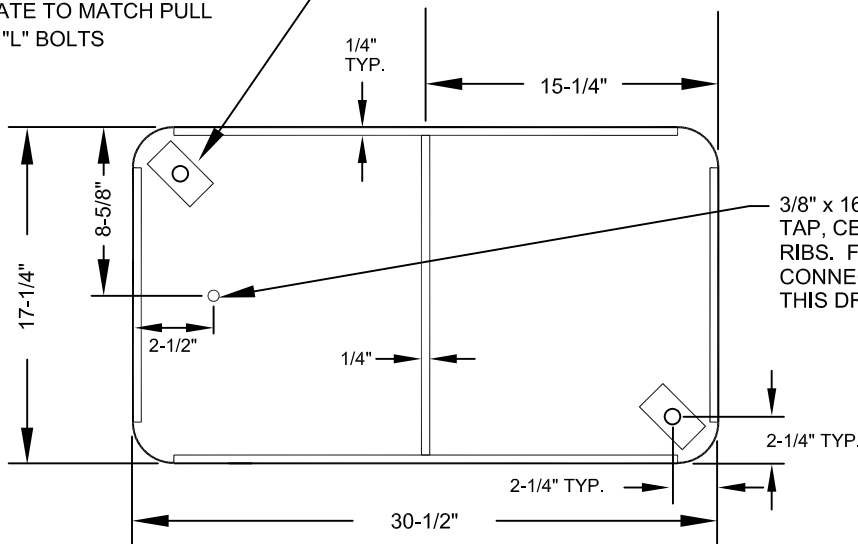

3/8" x 16 COARSE THREAD TAP, CENTERED BETWEEN RIBS. FOR COVER GROUND CONNECTION SEE SHEET 2 OF THIS DRAWING NO.

BOTTOM

NOTES:

1. THIS COVER TO BE USED IN STREET AREAS AND UNDEVELOPED AREAS ONLY.
2. TYPICAL NO. 7 PULL BOX COVER SHOWN. SUBMIT OTHERS TO THE ENGINEER FOR APPROVAL.
3. ALL TRAFFIC AND OPEN AREA COVERS SHALL BE H 20 RATED.
4. GROUNDING OF STEEL PULL BOX COVERS IS NOT NECESSARY FOR PULL BOXES CONTAINING LOW VOLTAGE, POWER-LIMITED CONNECTIONS.

SPECIFICATION REFERENCE

506	STEEL STRUCTURES
623	TRAFFIC SIGNALS & STREETLIGHTING

UNIFORM STANDARD DRAWINGS
CLARK COUNTY AREA

PULL BOX STREET COVER

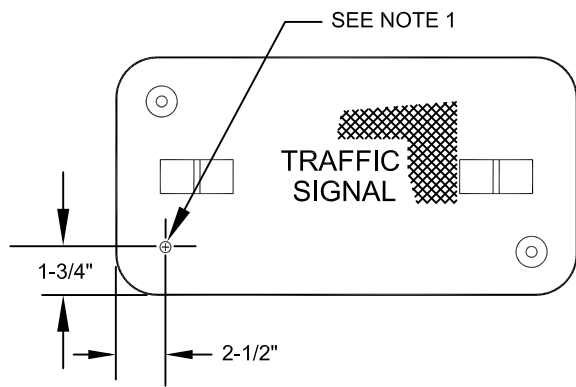

PULL BOX COVER - TOP VIEW

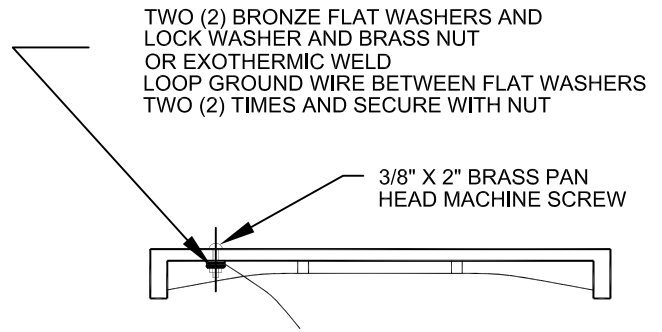

PULL BOX COVER - SIDE VIEW

TWO (2) BRONZE FLAT WASHERS AND LOCK WASHER AND BRASS NUT OR EXOTHERMIC WELD LOOP GROUND WIRE BETWEEN FLAT WASHERS TWO (2) TIMES AND SECURE WITH NUT

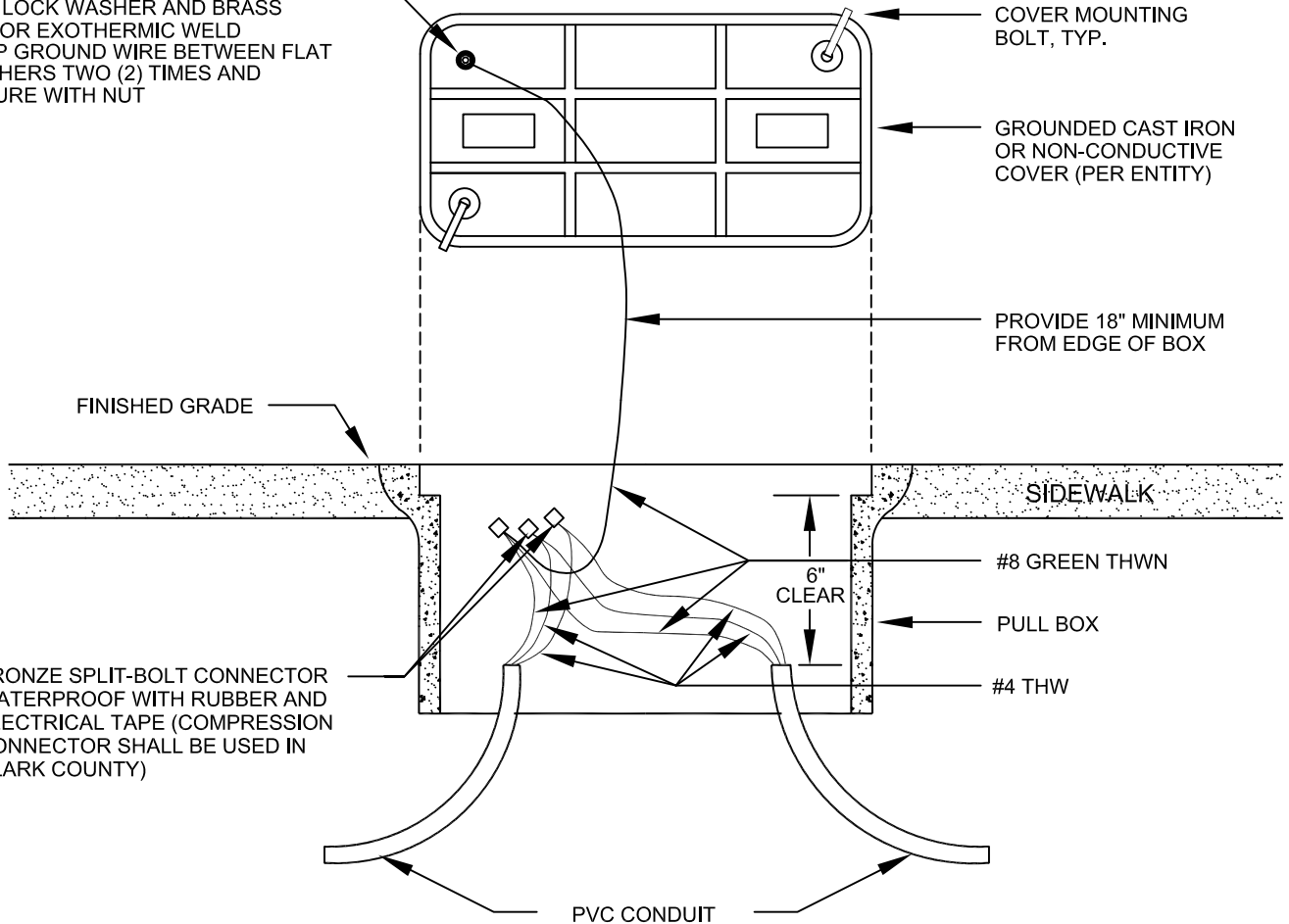

(TYPICAL CAST IRON LID SHOWN)

NOTES:

1. PULL BOX LID SHOULD BE TAPPED WITH A 3/8" X 16 COURSE THREAD TAP.
2. FOR TYPICAL NO. 7 PULL BOX COVER GROUNDING, SEE SHEET 1 OF THIS DRAWING NO.

SPECIFICATION REFERENCE

623 TRAFFIC SIGNALS & STREETLIGHTING

UNIFORM STANDARD DRAWINGS
CLARK COUNTY AREA

PULL BOX COVER
BONDING DETAIL

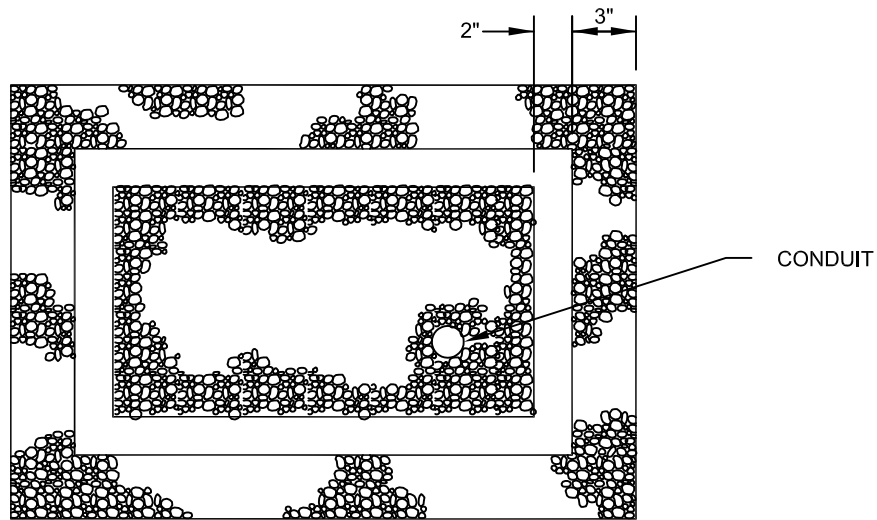
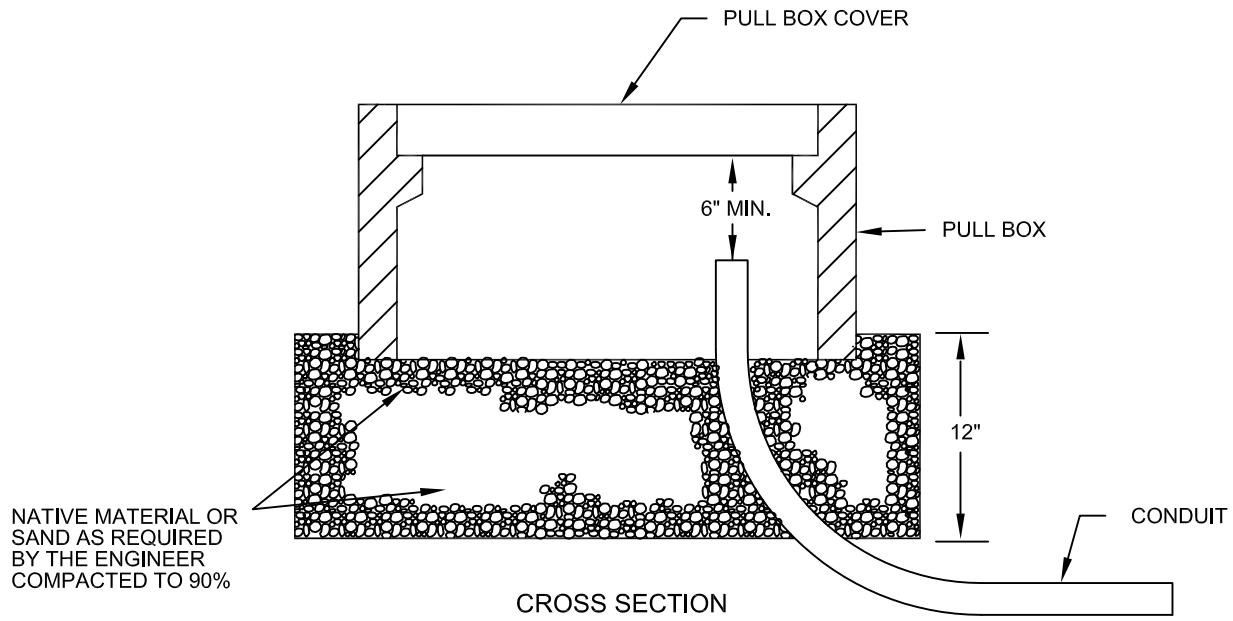

TOP VIEW

SPECIFICATION REFERENCE

UNIFORM STANDARD DRAWINGS
CLARK COUNTY AREA

PULL BOX
FOUNDATION

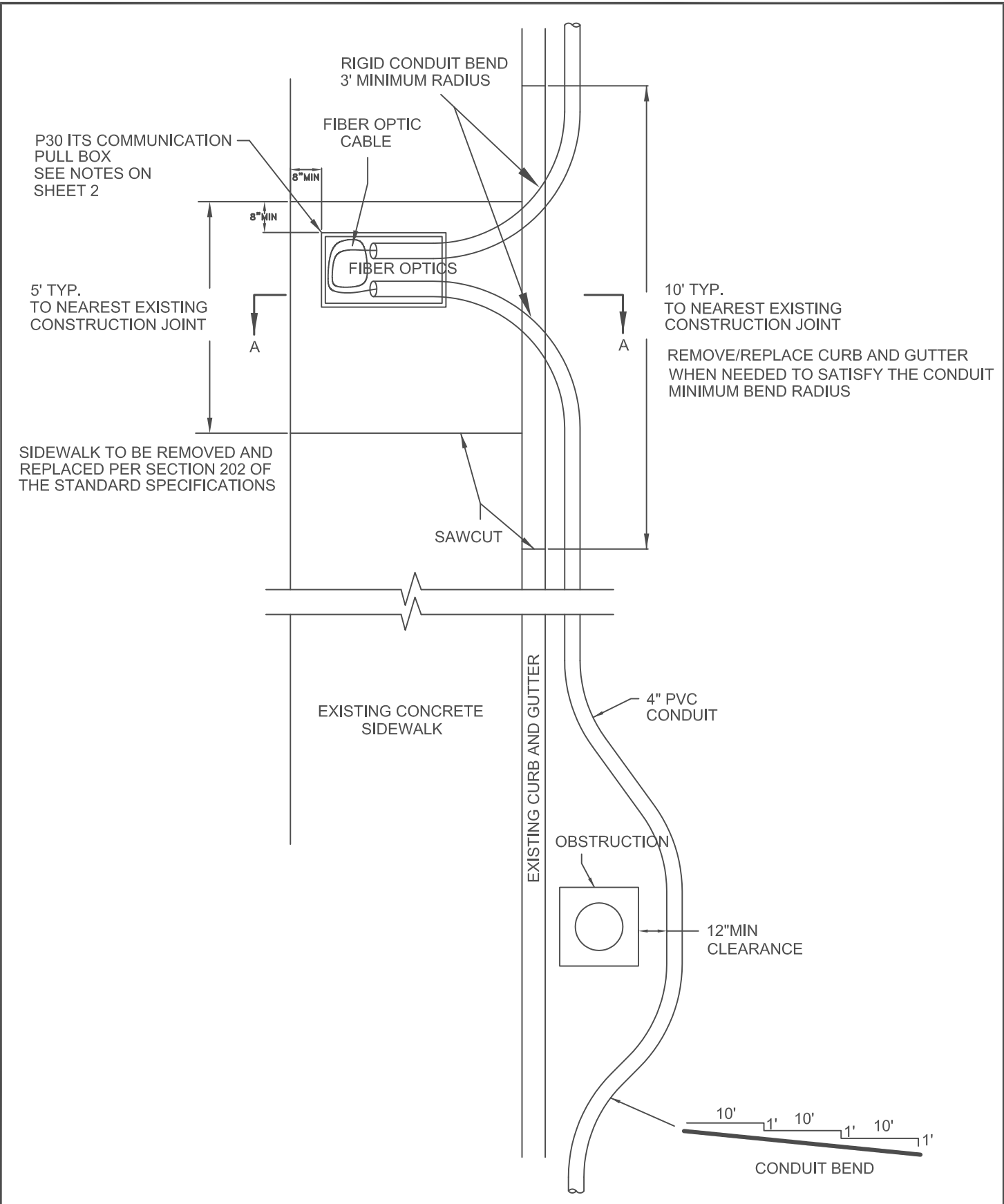

SPECIFICATION REFERENCE

UNIFORM STANDARD DRAWINGS
CLARK COUNTY AREA

ITS COMMUNICATION CONDUIT
AND PULL BOX DETAIL
(FOR EXISTING CURB & GUTTER)

DATE 3-13-08

DWG. NO. 404.142

SHEET 1 OF 2

PULL BOX MAY ALSO BE PLACED NEAR THE BACK OF CURB WITH A MIN. 8" CLEARANCE

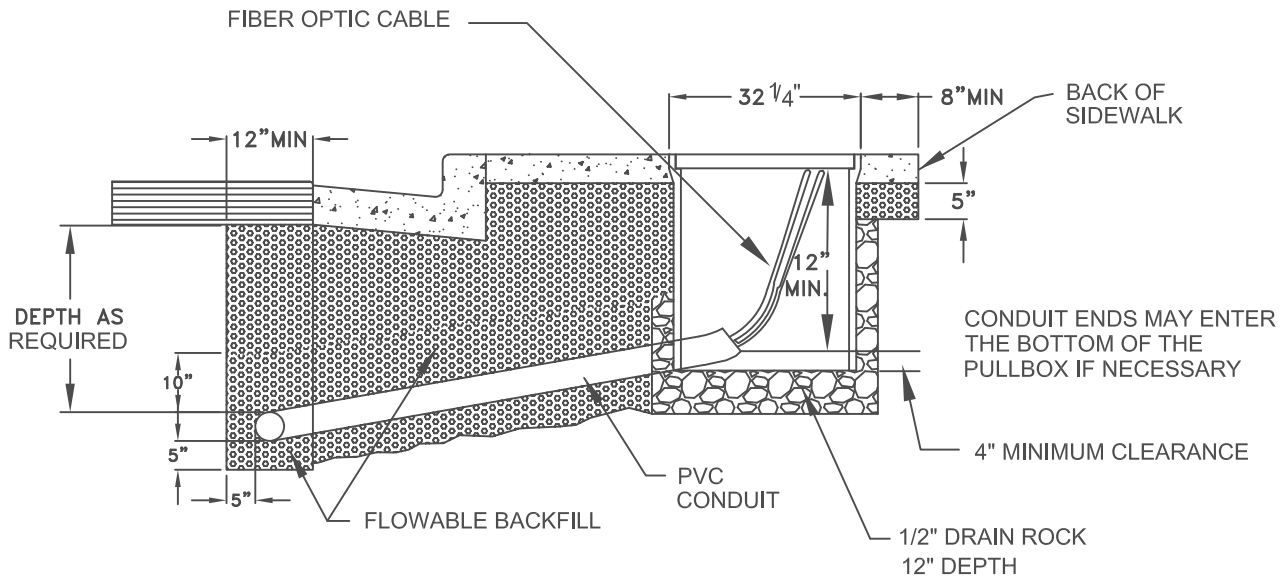

SECTION A-A

NOTES:

1. P30 PULL BOX SHALL BE INSTALLED FOR THE TRAFFIC SIGNAL ITS COMMUNICATIONS PER APPLICABLE STANDARDS.
2. PULL BOX COVER SHALL BE INSCRIBED "FIBER OPTICS".
3. APPROXIMATE LOCATIONS OF THE PROPOSED P30 ITS COMMUNICATION PULL BOXES ARE SHOWN ON THE PLANS. THE CONTRACTOR SHALL BE RESPONSIBLE FOR MARKING THE LOCATIONS OF THE PROPOSED ITS COMMUNICATION PULL BOXES IN THE FIELD PER STANDARD STANDARD SPECIFICATION INTERVALS AND THESE LOCATIONS SHALL BE SUBJECT TO APPROVAL OF THE ENGINEER BEFORE INSTALLATION.
4. DETAIL SHOWS METHOD OF INSTALLATION WHEN FIBER OPTIC CABLE IS REQUIRED.

SPECIFICATION REFERENCE

UNIFORM STANDARD DRAWINGS
CLARK COUNTY AREA

ITS COMMUNICATION CONDUIT
AND PULL BOX DETAIL
(FOR EXISTING CURB & GUTTER)

DATE 3-13-08

DWG. NO. 404.142

SHEET 2 OF 2

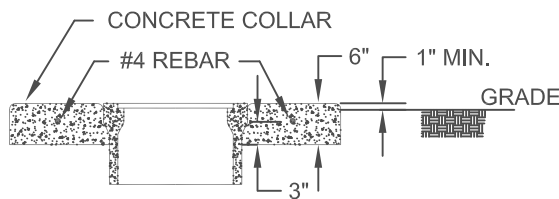
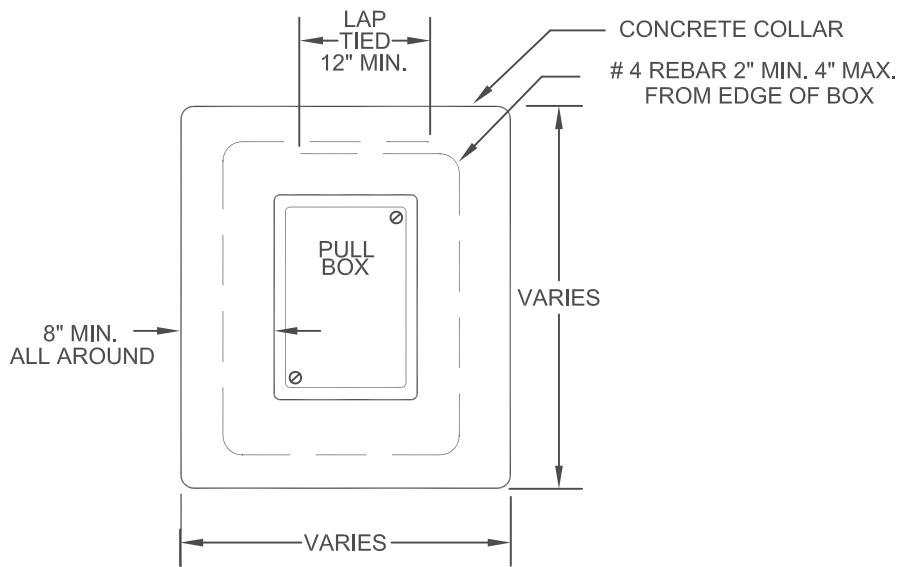

TYPICAL SECTION

PULL BOX CONCRETE COLLAR
IN UNDEVELOPED AREAS

NOTES:

1. P30 PULL BOXES SHALL BE INSTALLED FOR THE SIGNAL ITS COMMUNICATIONS PER APPLICABLE STANDARDS.
2. PULL BOX COVER SHALL BE INSCRIBED "FIBER OPTIC".
3. LOCATIONS OF THE PROPOSED P30 ITS COMMUNICATION PULL BOXES SHOWN ON THE PLANS ARE APPROXIMATE. THE CONTRACTOR SHALL BE RESPONSIBLE FOR MARKING THE LOCATIONS IN THE FIELD AT APPROXIMATELY 500 FEET INTERVALS. THESE LOCATIONS SHALL BE SUBJECT TO APPROVAL BY THE ENGINEER BEFORE INSTALLATION.
4. DETAIL SHOWS METHOD OF INSTALLATION WHEN FIBER OPTIC CABLE IS REQUIRED.
5. CONDUIT SIZES SHALL BE PER UNIFORM STANDARD SPECIFICATIONS, SECTION 623.
6. ALL CONDUITS SHALL HAVE A CONTINUOUS RUN OF 6 PAIR PE39 #22 AWG INTERCONNECT CABLE.
7. UNDERGROUND ORANGE MARKING TAPE SHALL BE PLACED 12 INCHES ABOVE THE INSTALLED CONDUIT AND MARKED WITH THE LEGEND "FIBER OPTIC".

SPECIFICATION REFERENCE		UNIFORM STANDARD DRAWINGS CLARK COUNTY AREA		
		PULL BOX CONCRETE COLLAR IN UNDEVELOPED AREAS		
		DATE	3-13-08	DWG. NO. 404.143
				SHEET 1 OF 1

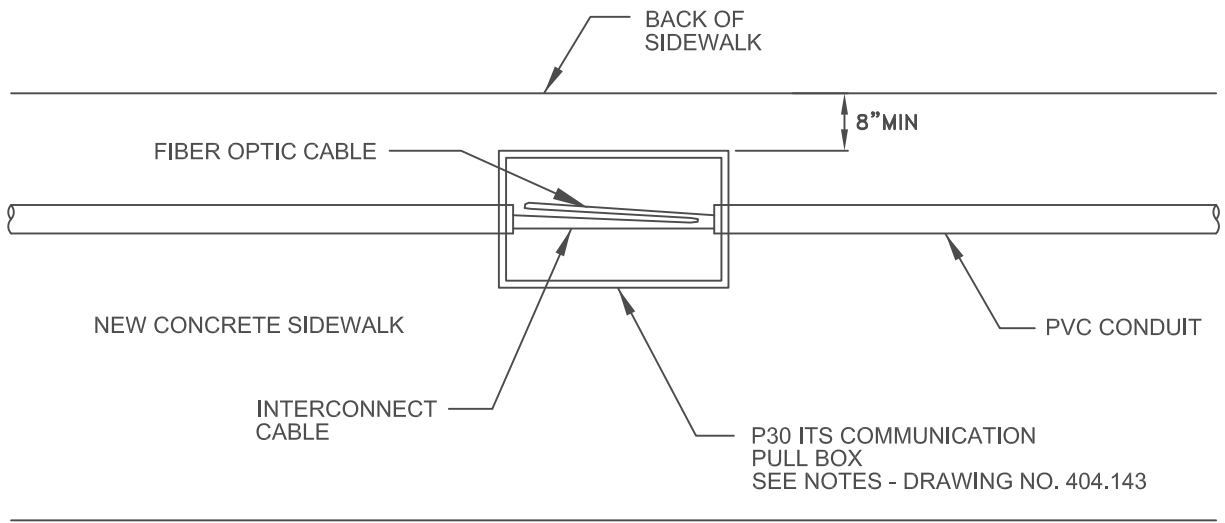

P30 ITS COMMUNICATION
PULL BOX
SEE NOTES - DRAWING NO. 404.143

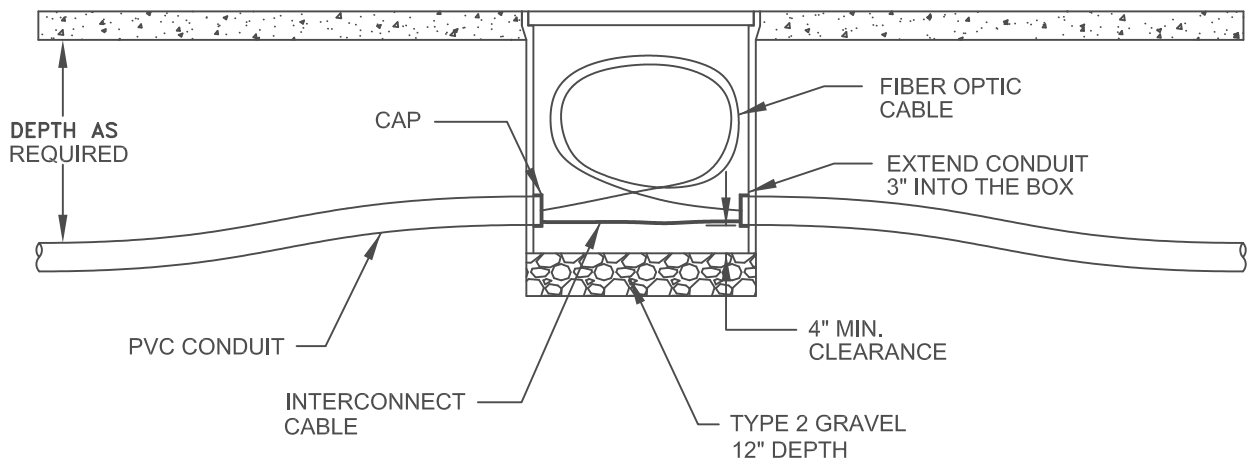

Effective 01/01/09 - 06/30/09

SPECIFICATION REFERENCE		UNIFORM STANDARD DRAWINGS CLARK COUNTY AREA			
		ITS COMMUNICATION CONDUIT AND PULL BOX DETAIL INSTALLED UNDER NEW SIDEWALK			
		DATE 3-13-08	DWG. NO. 404.144	SHEET	1 OF 1

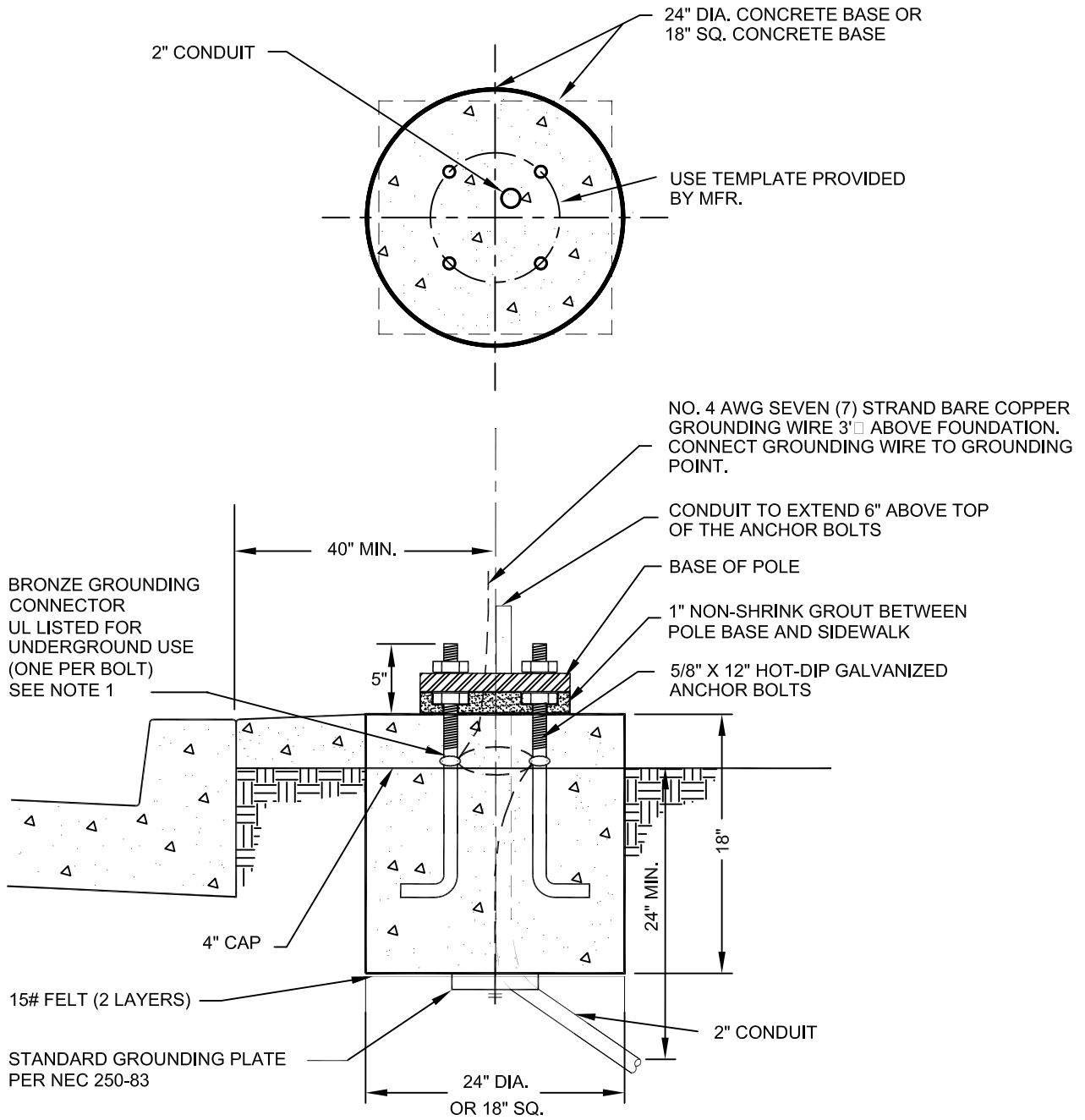

NOTE:

1. CONTINUOUS BARE COPPER GROUNDING WIRE SHALL BE LOOPED AROUND ANCHOR BOLTS ONE TIME AND CONNECTED TO EACH ANCHOR BOLT BEFORE CONTINUING DOWN TO THE GROUNDING PLATE.

SPECIFICATION REFERENCE

623G.03.06 FOUNDATION
623T.02.02 ANCHOR BOLT

UNIFORM STANDARD DRAWINGS
CLARK COUNTY AREA

TYPE "A" FOUNDATION

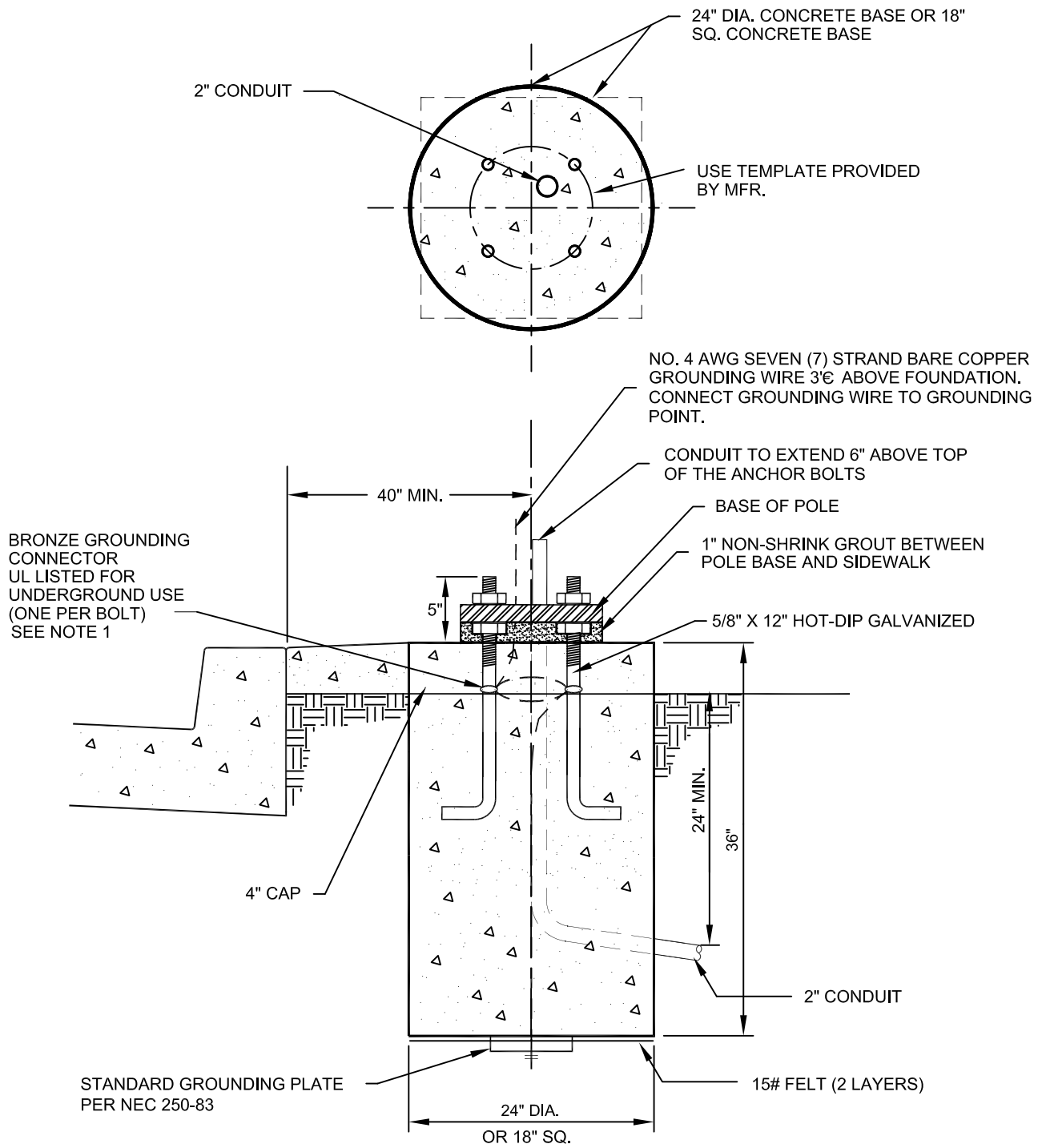

NOTE:

1. CONTINUOUS BARE COPPER GROUNDING WIRE SHALL BE LOOPED AROUND ANCHOR BOLTS ONE TIME AND CONNECTED TO EACH ANCHOR BOLT BEFORE CONTINUING DOWN TO THE GROUNDING PLATE.

SPECIFICATION REFERENCE

623G.03.06 FOUNDATION
 623T.02.02 ANCHOR BOLT

**UNIFORM STANDARD DRAWINGS
 CLARK COUNTY AREA**

TYPE "B" FOUNDATION

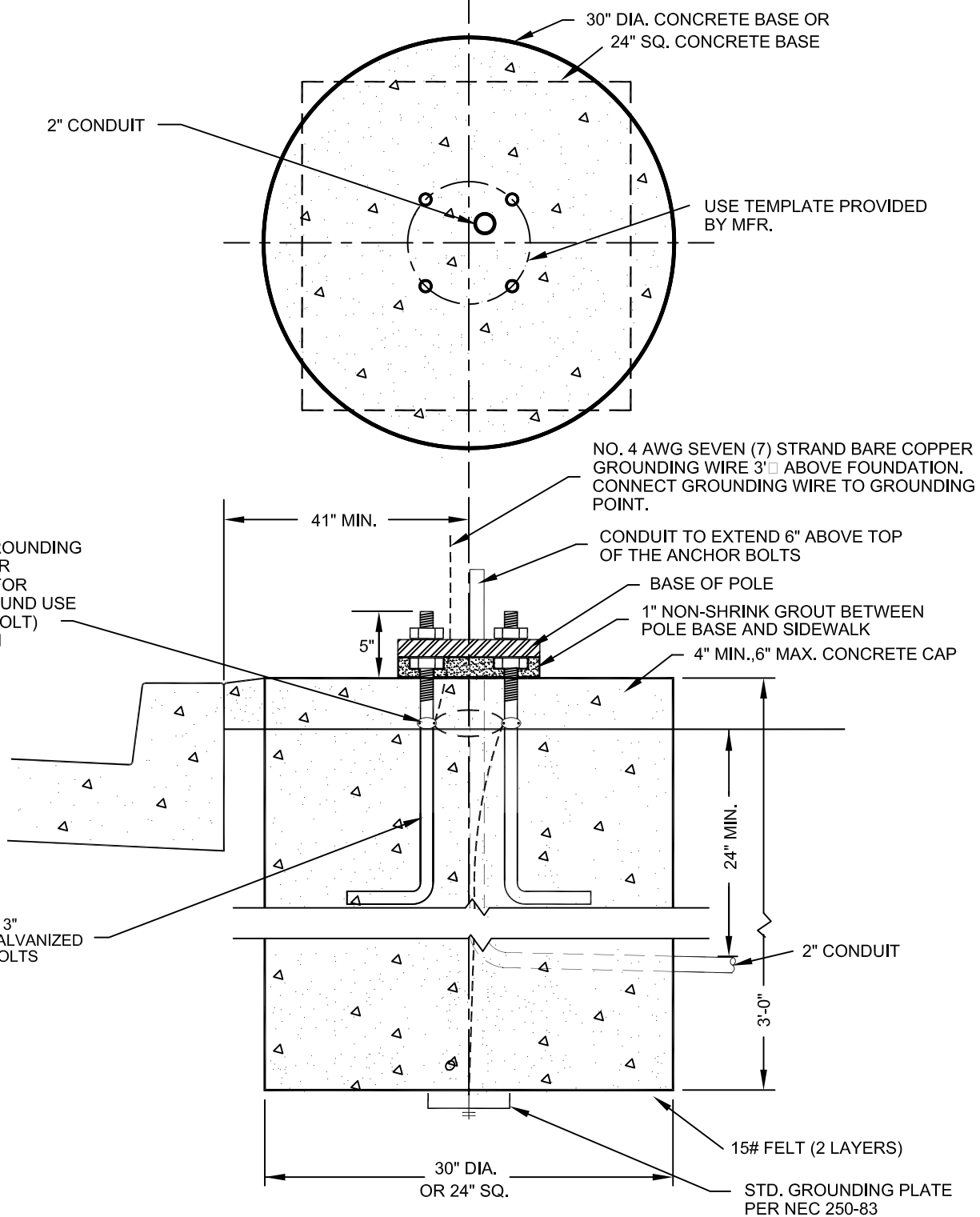

NOTE:

1. CONTINUOUS BARE COPPER GROUNDING WIRE SHALL BE LOOPED AROUND ANCHOR BOLTS ONE TIME AND CONNECTED TO EACH ANCHOR BOLT BEFORE CONTINUING DOWN TO THE GROUNDING PLATE.

Effective 01/01/09 - 06/30/09

SPECIFICATION REFERENCE		UNIFORM STANDARD DRAWINGS CLARK COUNTY AREA	
623G.03.06 FOUNDATION		TYPE "C" FOUNDATION	
623T.02.02 ANCHOR BOLT			
		DATE 9-14-00	DWG. NO. 404.203
		SHEET 1 OF 1	

NOTES:

1. ANCHOR BOLTS SHALL BE HOT-DIP GALVANIZED STEEL WITH NUT AND WASHER.
2. CONTINUOUS BARE COPPER GROUNDING WIRE SHALL BE LOOPED AROUND ANCHOR BOLTS ONE TIME AND CONNECTED TO EACH ANCHOR BOLT BEFORE CONTINUING DOWN TO THE GROUNDING PLATE.

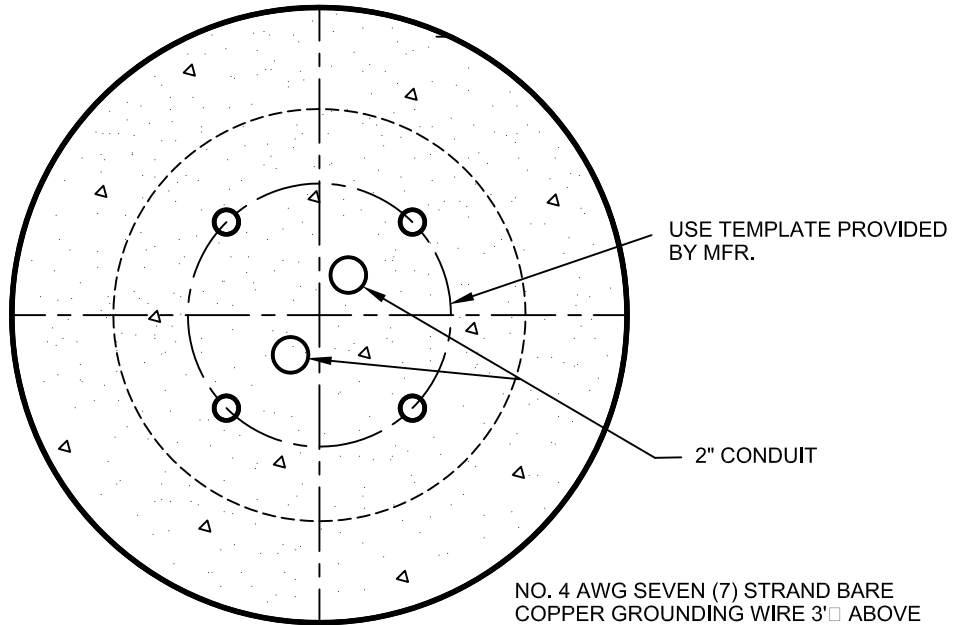

ANCHOR BOLTS	
POLE GA.	BOLT "E"
11	SEE POLE DRAWING
7	1-1/8" X 40" X 4"
3	1-1/4" X 44" X 4"

BRONZE GROUNDING CONNECTOR UL LISTED FOR UNDERGROUND USE (ONE PER BOLT) SEE NOTE 2

NO. 4 AWG SEVEN (7) STRAND BARE COPPER GROUNDING WIRE 3' ABOVE FOUNDATION. CONNECT GROUNDING WIRE TO GROUNDING POINT.

CONDUIT TO EXTEND 6" ABOVE TOP OF THE ANCHOR BOLTS
 BASE OF POLE
 1" NON-SHRINK GROUT BETWEEN POLE BASE AND SIDEWALK
 4" MIN.-6" MAX. CONCRETE CAP

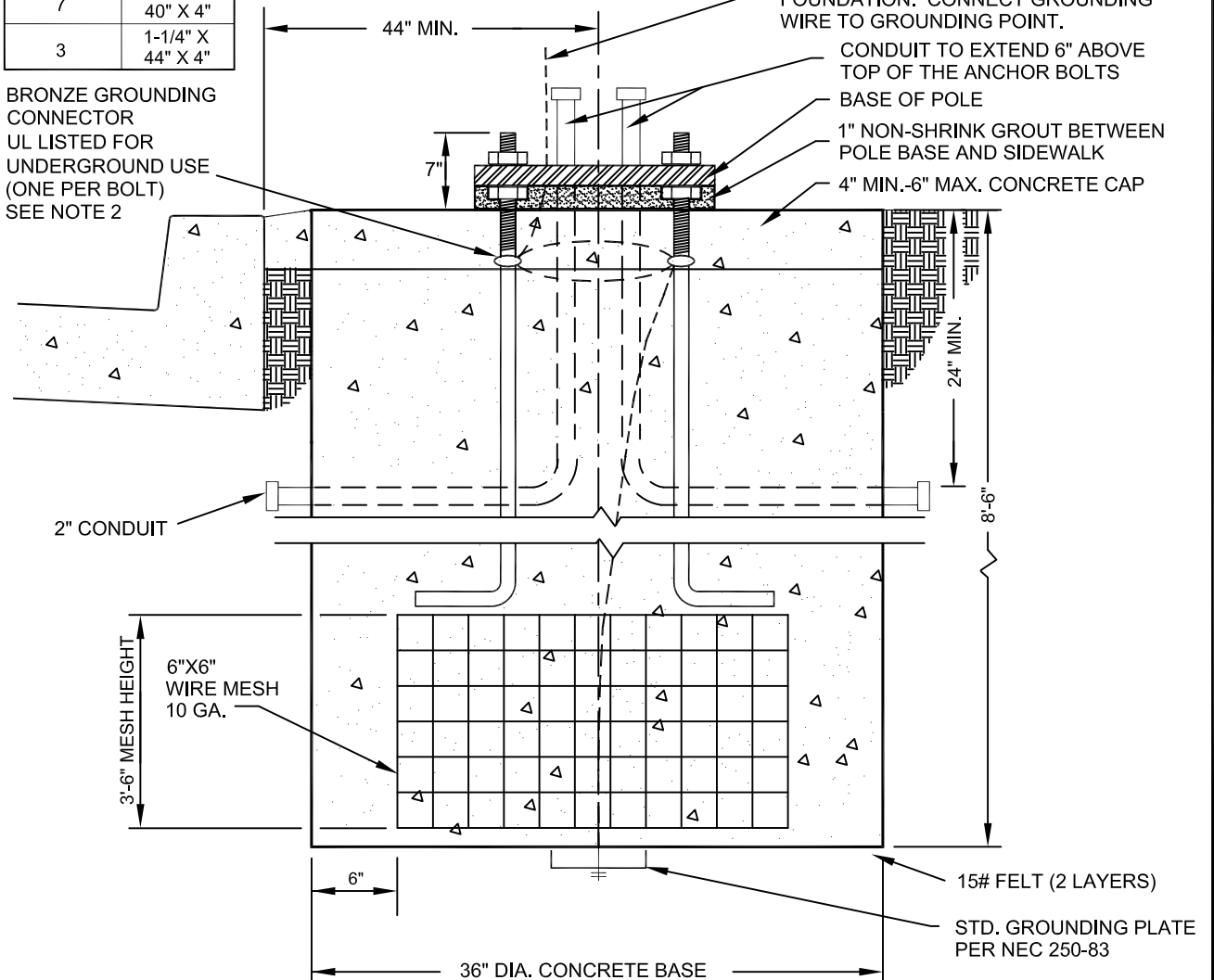

Effective 01/01/09 - 06/30/09

SPECIFICATION REFERENCE		UNIFORM STANDARD DRAWINGS CLARK COUNTY AREA	
623G.03.06 FOUNDATION		TYPE "E" FOUNDATION	
DATE	9-14-00	DWG. NO.	404.205
		SHEET	1 OF 1

NOTES:

- ANCHOR BOLTS SHALL BE HOT-DIP GALVANIZED STEEL WITH NUT AND WASHER.
- CONTINUOUS BARE COPPER GROUNDING WIRE SHALL BE LOOPED AROUND ANCHOR BOLTS ONE TIME CONNECTED TO EACH ANCHOR BOLT BEFORE CONTINUING DOWN TO THE GROUNDING PLATE.

ANCHOR BOLTS	
POLE GA.	BOLT "E"
11	SEE POLE DRAWING
7	1-1/8" X 40" X 4"
3	1-1/4" X 44" X 4"

BRONZE GROUNDING CONNECTOR UL LISTED FOR UNDERGROUND USE (ONE PER BOLT) SEE NOTE 2

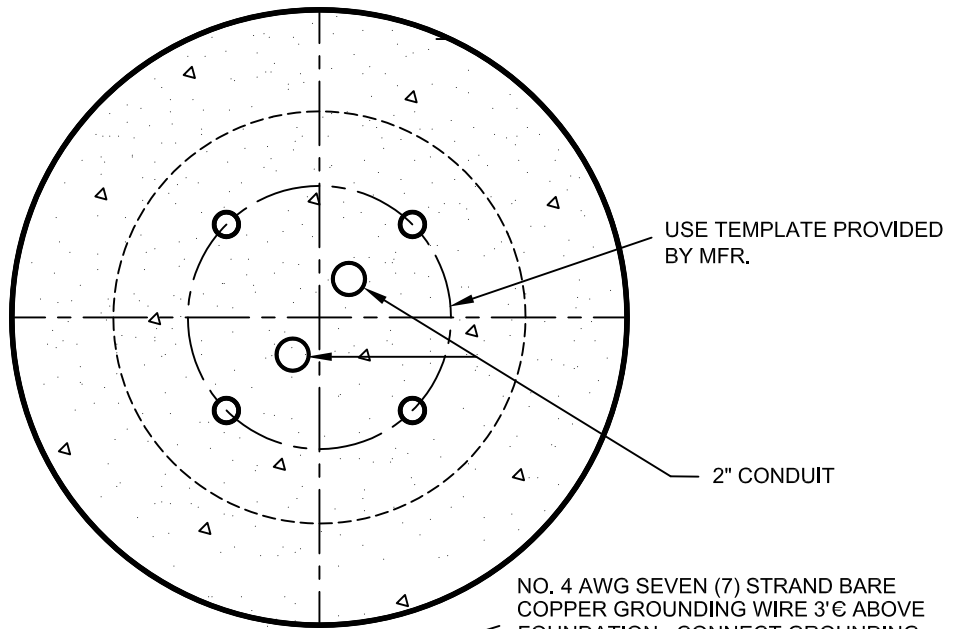

NO. 4 AWG SEVEN (7) STRAND BARE COPPER GROUNDING WIRE 3'± ABOVE FOUNDATION. CONNECT GROUNDING WIRE TO GROUNDING POINT.

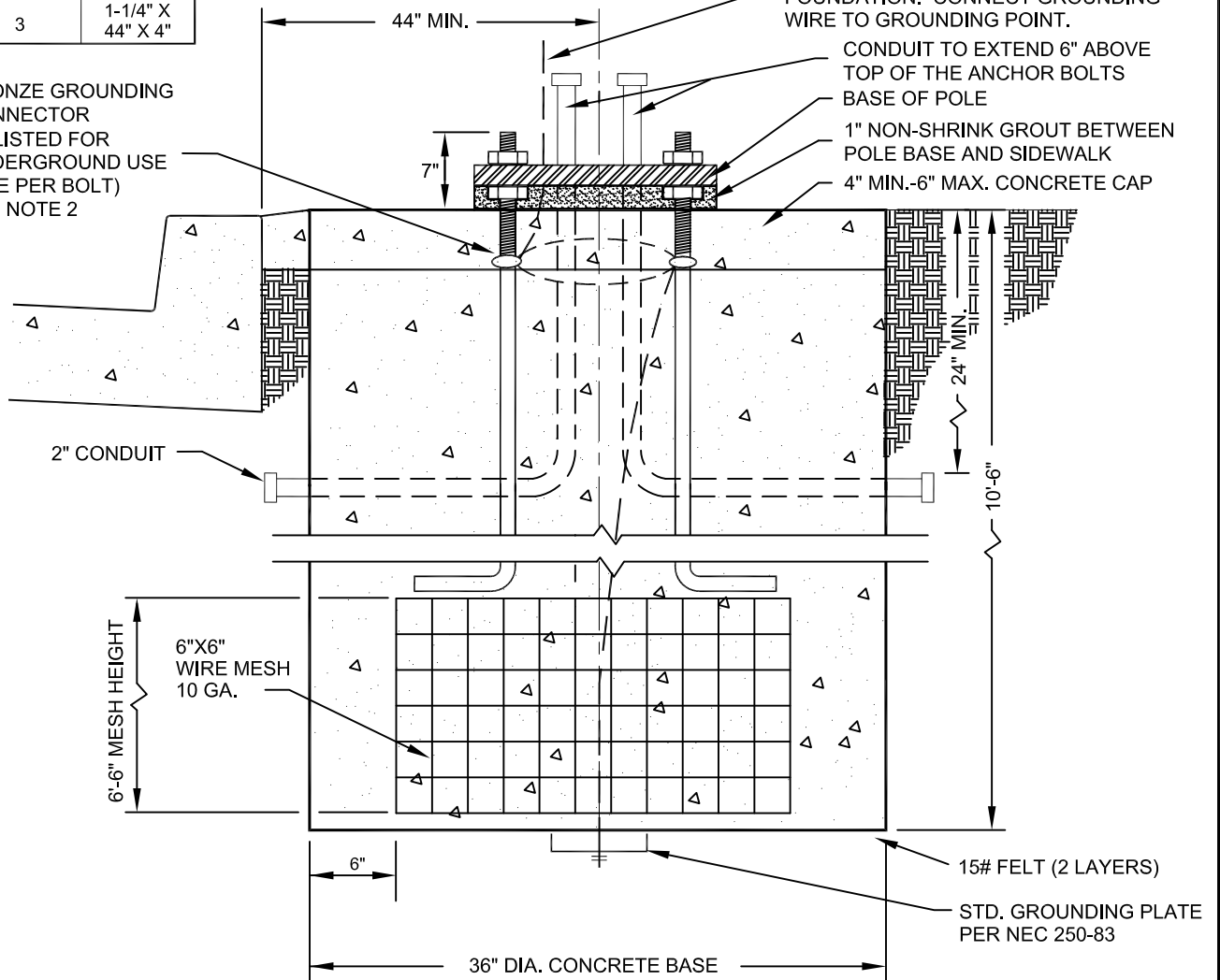

SPECIFICATION REFERENCE

UNIFORM STANDARD DRAWINGS
CLARK COUNTY AREA

623G.03.06 FOUNDATION

TYPE "F" FOUNDATION

NOTES:

- ANCHOR BOLTS SHALL BE HOT-DIP GALVANIZED STEEL WITH NUT AND WASHER.
- CONTINUOUS BARE COPPER GROUNDING WIRE SHALL BE LOOPED AROUND ANCHOR BOLTS ONE TIME CONNECTED TO EACH ANCHOR BOLT BEFORE CONTINUING DOWN TO THE GROUNDING PLATE.

ANCHOR BOLTS	
POLE GA.	BOLT "E"
11	SEE POLE DRAWING
7	1-1/8" X 40" X 4"
3	1-1/4" X 44" X 4"

BRONZE GROUNDING CONNECTOR UL LISTED FOR UNDERGROUND USE (ONE PER BOLT) SEE NOTE 2

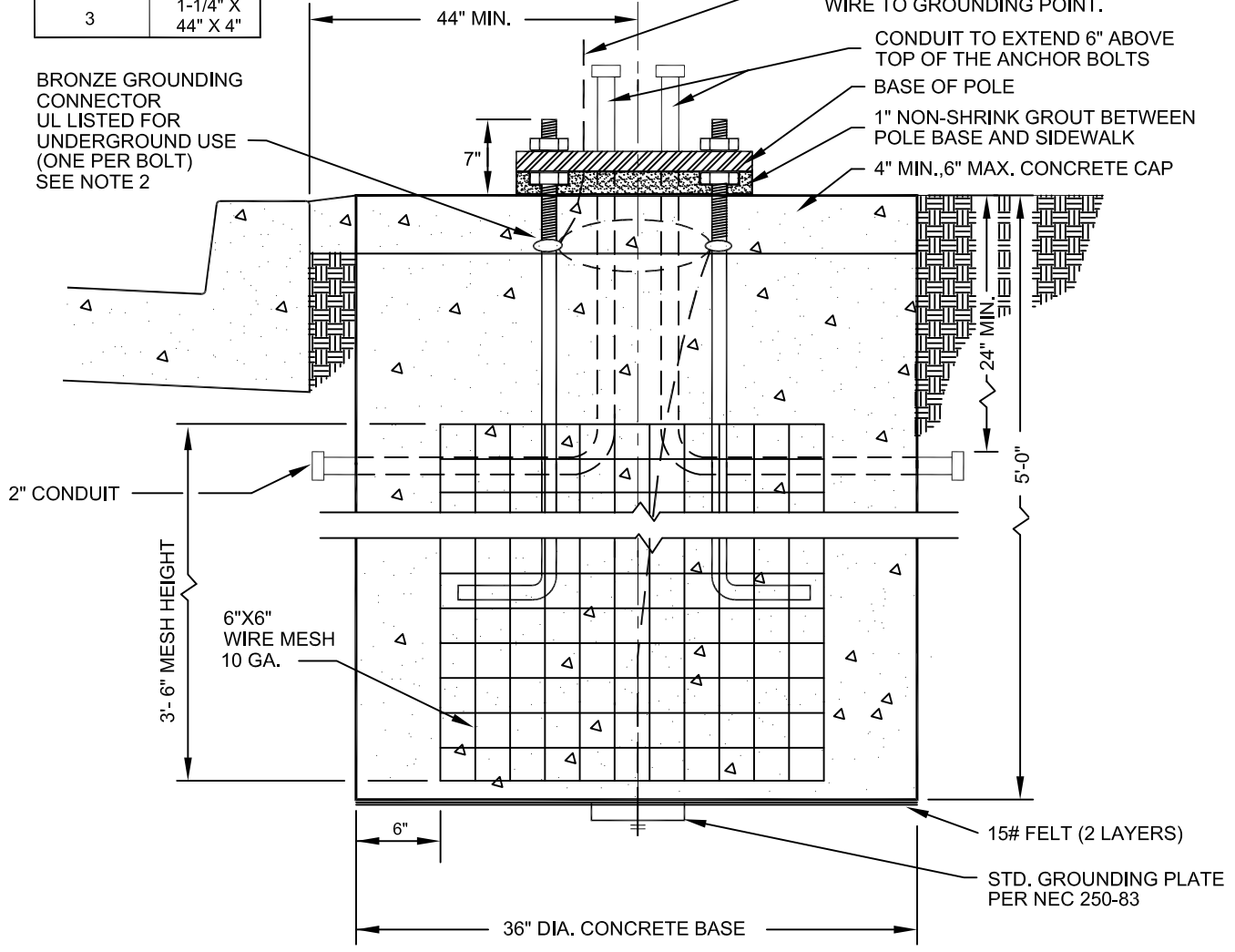
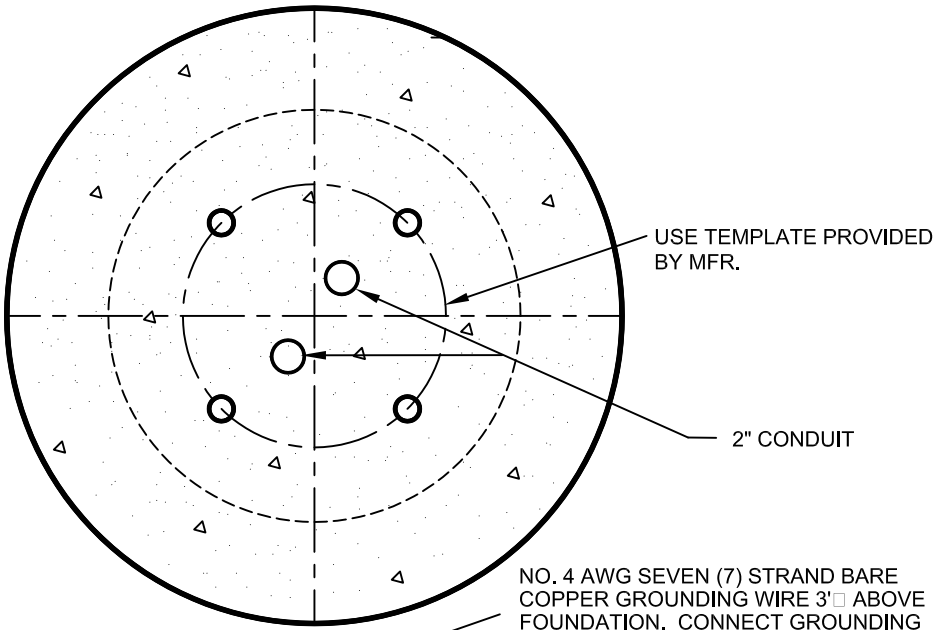

Effective 01/01/09 - 06/30/09

SPECIFICATION REFERENCE		UNIFORM STANDARD DRAWINGS CLARK COUNTY AREA			
623G.03.06 FOUNDATION		TYPE "G" FOUNDATION			
DATE	9-14-00	DWG. NO.	404.207	SHEET	1 OF 1

NOTES:

1. ANCHOR BOLTS SHALL BE HOT-DIP GALVANIZED STEEL WITH NUT AND WASHER.
2. CONTINUOUS BARE COPPER GROUNDING WIRE SHALL BE LOOPED AROUND ANCHOR BOLTS ONE TIME AND CONNECTED TO EACH ANCHOR BOLT BEFORE CONTINUING DOWN TO THE GROUNDING PLATE.

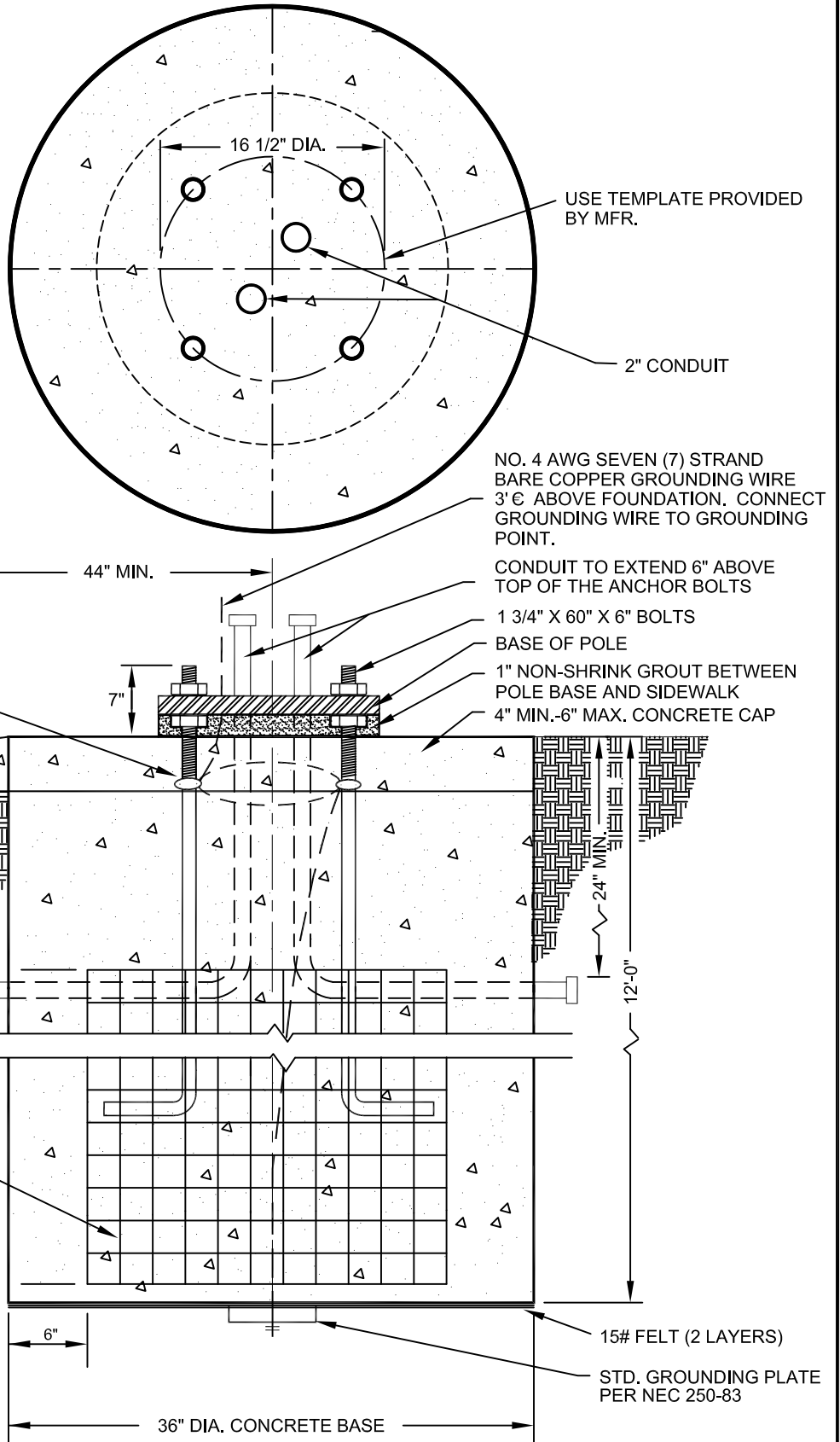

SPECIFICATION REFERENCE

UNIFORM STANDARD DRAWINGS
CLARK COUNTY AREA

623G.03.06 FOUNDATION

TYPE "H" FOUNDATION

NOTES:

1. ANCHOR BOLTS SHALL BE HOT-DIP GALVANIZED STEEL WITH NUT AND WASHER.
2. ANCHOR BOLT MINIMUM YIELD STRENGTH $F_y = 50$ KSI.
3. SURROUNDING SOIL MUST HAVE SOIL-BEARING PRESSURE S_1 OF 1500 PSF.
4. WRAP 20' OF #4 AWG BARE COPPER GROUNDING WIRE AROUND ENTIRE CAGE. GROUNDING WIRE SHALL BE CONNECTED TO ONE ANCHOR BOLT NEAR TOP OF FOUNDATION AND CONTINUE DOWN AROUND CAGE AND CONNECT TO GROUNDING PLATE AT BOTTOM OF FOUNDATION.
5. STEEL WIRE SHALL BE USED TO TIE ALL BARS AND WIRE MESH FIRMLY TOGETHER.

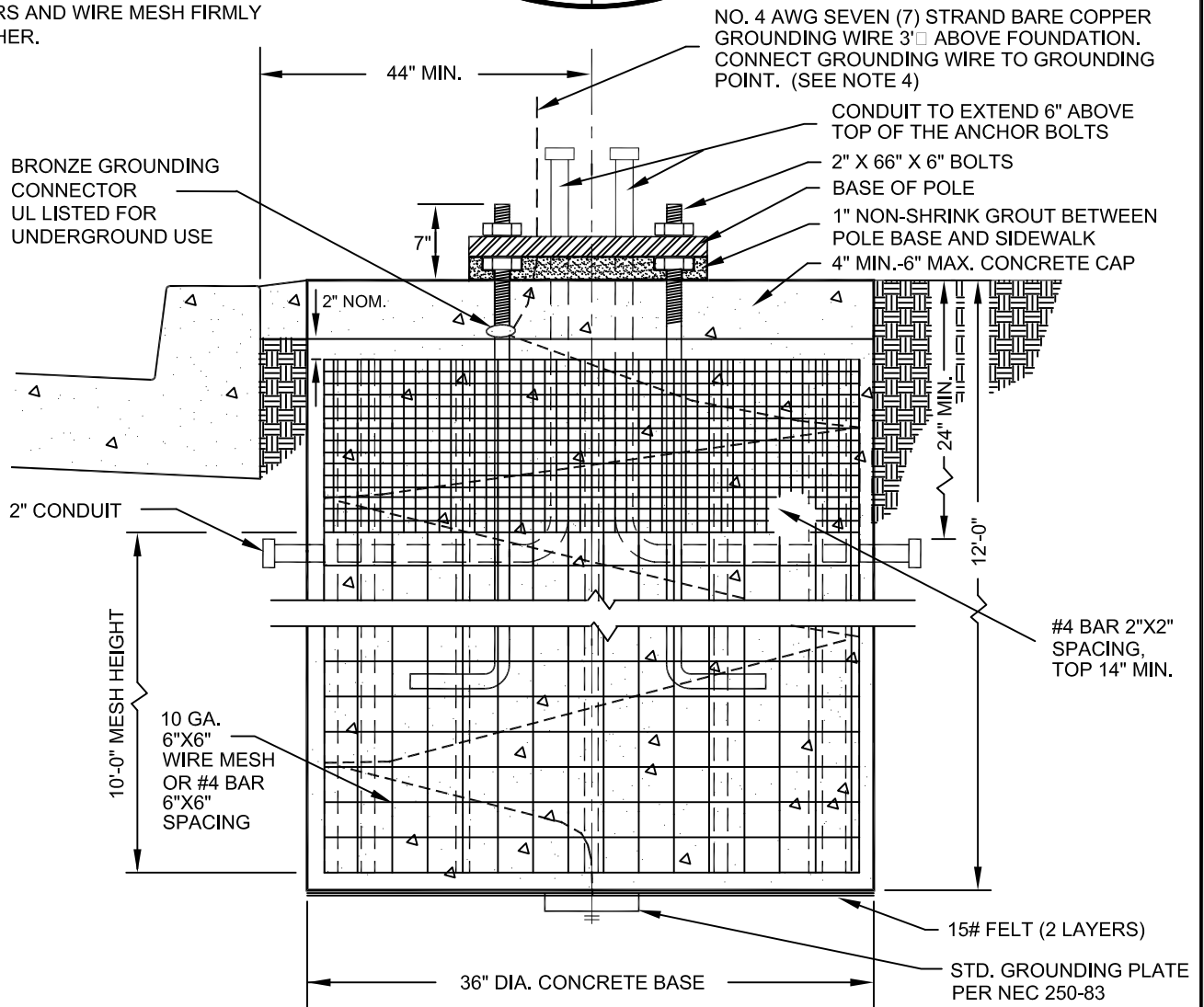
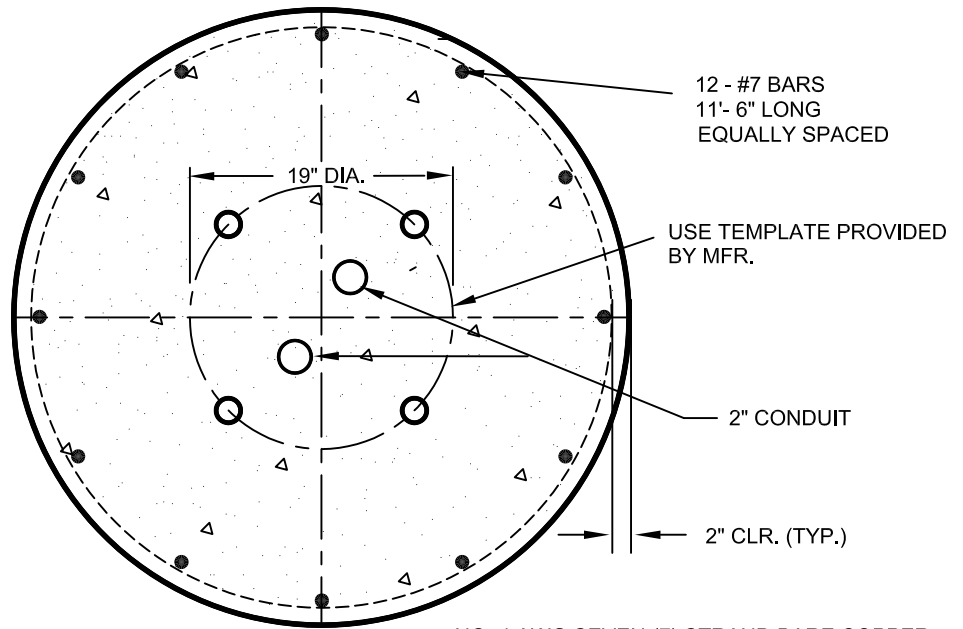

NO. 4 AWG SEVEN (7) STRAND BARE COPPER GROUNDING WIRE 3' ABOVE FOUNDATION. CONNECT GROUNDING WIRE TO GROUNDING POINT. (SEE NOTE 4)

CONDUIT TO EXTEND 6" ABOVE TOP OF THE ANCHOR BOLTS

2" X 66" X 6" BOLTS

BASE OF POLE

1" NON-SHRINK GROUT BETWEEN POLE BASE AND SIDEWALK

4" MIN.-6" MAX. CONCRETE CAP

#4 BAR 2"X2" SPACING, TOP 14" MIN.

15# FELT (2 LAYERS)

STD. GROUNDING PLATE PER NEC 250-83

SPECIFICATION REFERENCE

UNIFORM STANDARD DRAWINGS
CLARK COUNTY AREA

623G.03.06 FOUNDATION

TYPE "L" FOUNDATION

NOTES:

1. ANCHOR BOLTS SHALL BE HOT-DIP GALVANIZED STEEL WITH NUT AND WASHER.
2. WRAP 20' OF #4 AWG BARE COPPER GROUNDING WIRE AROUND ENTIRE CAGE. GROUNDING WIRE SHALL BE CONNECTED TO ONE ANCHOR BOLT NEAR TOP OF FOUNDATION AND CONTINUE DOWN AROUND CAGE AND CONNECT TO GROUNDING PLATE AT BOTTOM OF FOUNDATION.
3. STEEL WIRE SHALL BE USED TO TIE ALL BARS AND SPIRAL FIRMLY TOGETHER.
4. 28 DAY STRENGTH - 4000 PSI MIN. ALL REINFORCING STEEL SHALL BE ASTM A615 GR 60.
5. MAXIMUM ALLOWABLE OVERTURNING MOMENT IS 180 FT-KIPS.
6. MAXIMUM ALLOWABLE TORSION IS 220 FT-KIPS.
7. THE FOUNDATION DESIGN SHOWN ASSUMES A NON-COHESIVE SOIL WITH A MINIMUM INTERNAL FRICTION ANGLE OF 30 DEGREES. IF ACTUAL SOIL CONDITIONS ARE LESSER QUALITY, THE FOUNDATION SHOULD BE DESIGNED FOR THE SPECIFIC SITE CONDITIONS.

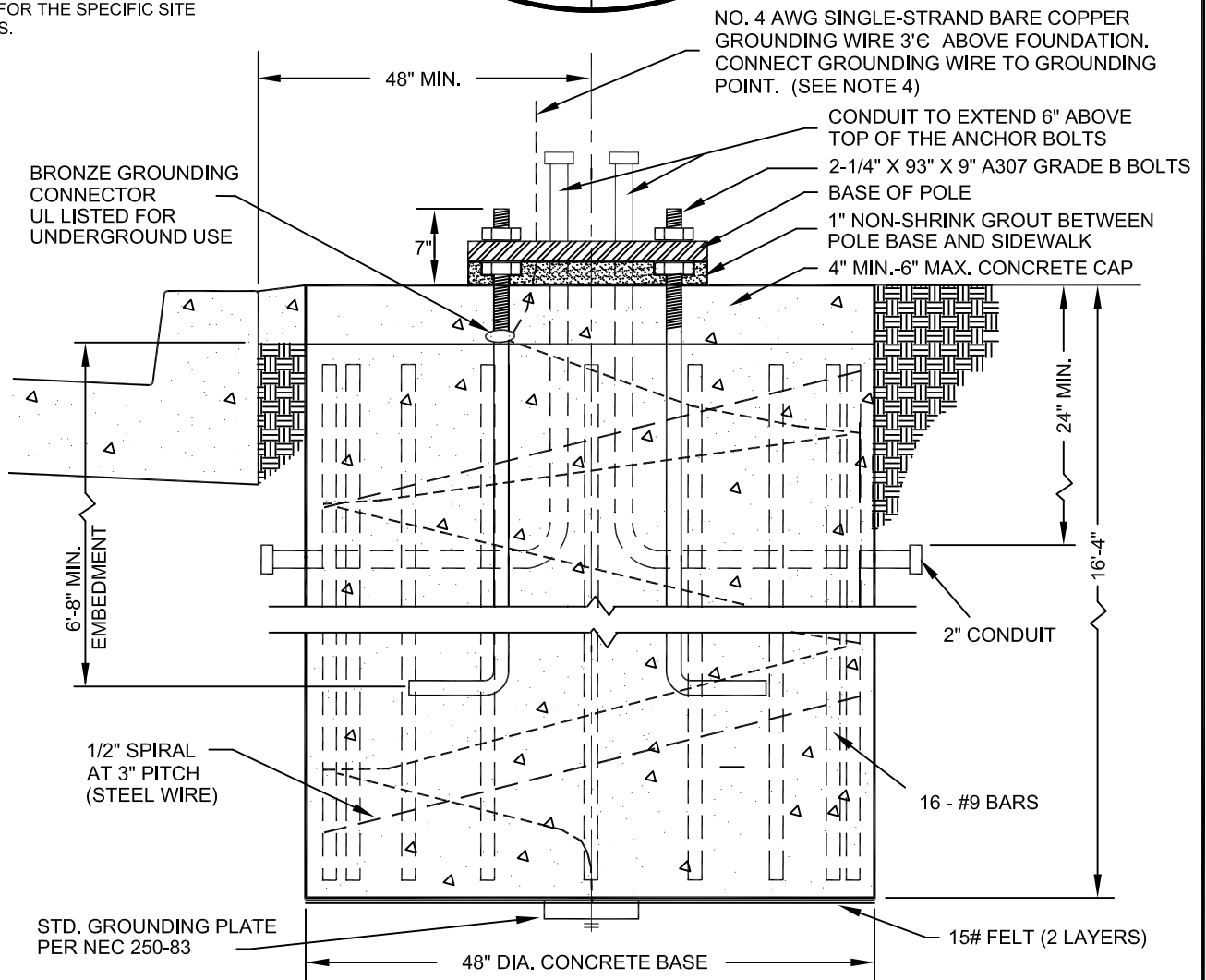
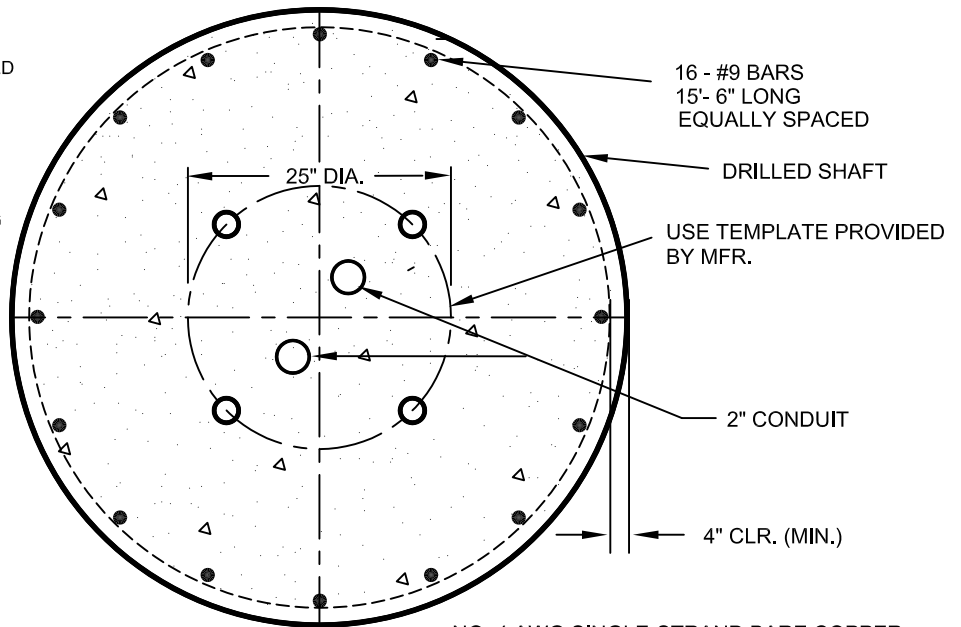

NO. 4 AWG SINGLE-STRAND BARE COPPER GROUNDING WIRE 3'± ABOVE FOUNDATION. CONNECT GROUNDING WIRE TO GROUNDING POINT. (SEE NOTE 4)

CONDUIT TO EXTEND 6" ABOVE TOP OF THE ANCHOR BOLTS
 2-1/4" X 93" X 9" A307 GRADE B BOLTS
 BASE OF POLE
 1" NON-SHRINK GROUT BETWEEN POLE BASE AND SIDEWALK
 4" MIN.-6" MAX. CONCRETE CAP

FOR TYPE XX-B SIGNAL AND LUMINAIRE POLES, SEE STANDARD DRAWING NOS. 404.406, 404.407 AND 404.409.

SPECIFICATION REFERENCE

UNIFORM STANDARD DRAWINGS
 CLARK COUNTY AREA

623G.03.06 FOUNDATION

TYPE "M" FOUNDATION

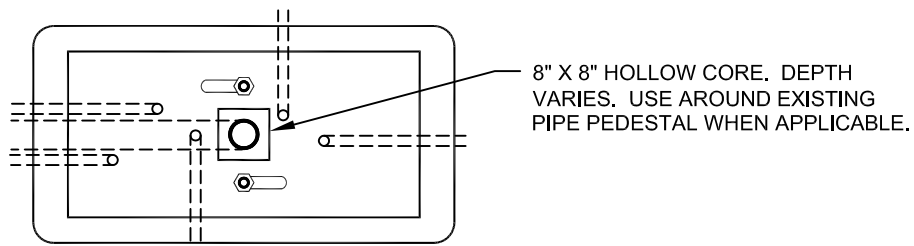

6' OF #4 AWG SEVEN (7) STRAND BARE COPPER GROUNDING WIRE ABOVE FOUNDATION CONNECT GROUNDING WIRE TO GROUNDING POINT.

2" PVC CONDUIT TO BE ADDED IN EVERY FOUNDATION FOR FUTURE USE. POINT TOWARD INTERSECTION.

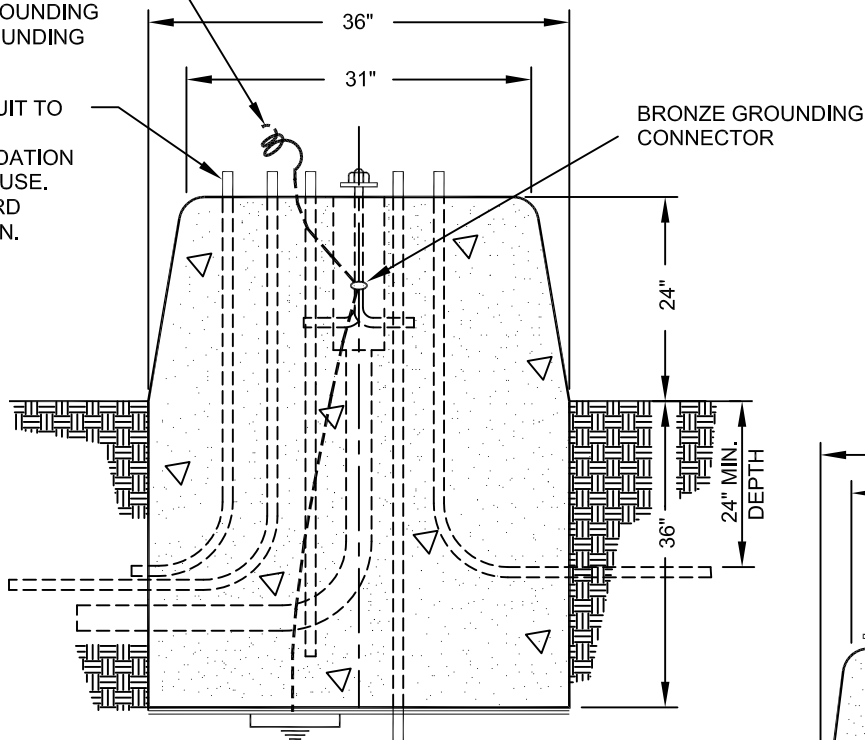

BRONZE GROUNDING CONNECTOR UL LISTED FOR UNDERGROUND USE (ONE PER BOLT) SEE NOTE 5

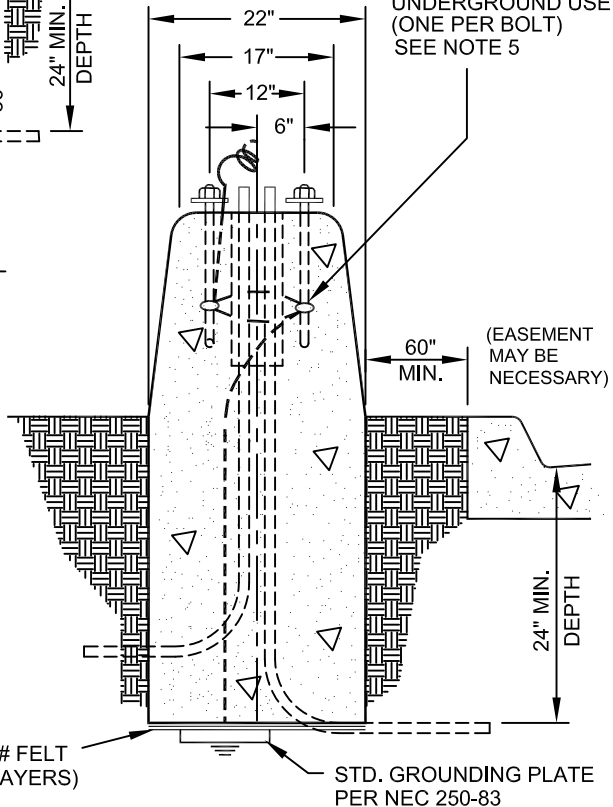

NOTES:

1. FOR CONDUIT SIZE, LOCATION AND QUANTITY, SEE PLANS.
2. ANCHOR BOLTS 3/4" X 18" X 3" SHALL BE HOT-DIP GALVANIZED COMMERCIAL GRADE STEEL WITH NUT AND WASHER.
3. ANCHOR BOLT PROJECTION ABOVE FOUNDATION SHALL BE 3-1/2" MIN., 4-1/2" MAX.
4. CONDUIT PROJECTION ABOVE FOUNDATION SHALL BE 2" MIN., 4" MAX.
5. CONTINUOUS BARE COPPER GROUNDING WIRE SHALL BE LOOPED AROUND ANCHOR BOLTS ONE TIME AND CONNECTED TO EACH ANCHOR BOLT BEFORE CONTINUING DOWN TO THE GROUNDING PLATE.

SPECIFICATION REFERENCE

UNIFORM STANDARD DRAWINGS
CLARK COUNTY AREA

TYPE "I" FOUNDATION

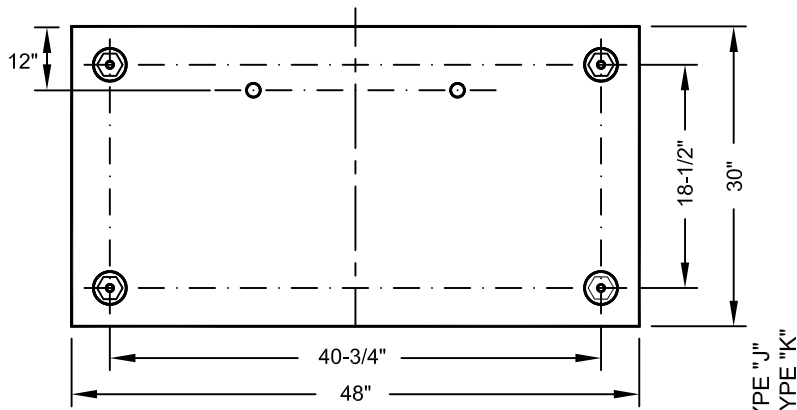

NOTES:

1. FOR CONDUIT SIZE, LOCATION, AND QUANTITY SEE PLANS REFER TO CONDUIT LAYOUT DRAWING # 404.213A FOR DETAILS.
2. 3/4" X 18" X 3" HOT-DIP GALVANIZED ANCHOR BOLTS. LOCATE WITH TEMPLATE.
3. ANCHOR BOLT PROJECTION ABOVE FOUNDATION SHALL BE 3-1/2" MIN. , 4-1/2" MAX.
4. CONDUIT PROJECTION ABOVE FOUNDATION SHALL BE 1" MIN. , 4" MAX.
5. LOCATION OF FOUNDATION MUST BE APPROVED BY ENGINEER IN FIELD.
6. CONTINUOUS BARE COPPER GROUNDING WIRE SHALL BE CONNECTED TO EACH ANCHOR BOLT WITH BRONZE GROUNDING CONNECTOR BEFORE CONTINUING DOWN TO THE GROUNDING PLATE.

2" PVC COND. TO BE ADDED IN EVERY FDN. , FOR FUTURE USE. POINT TOWARDS INTERSECTION.

BRONZE GROUNDING CONNECTOR UL LISTED FOR UNDERGROUND USE (ONE PER BOLT) SEE NOTE 6

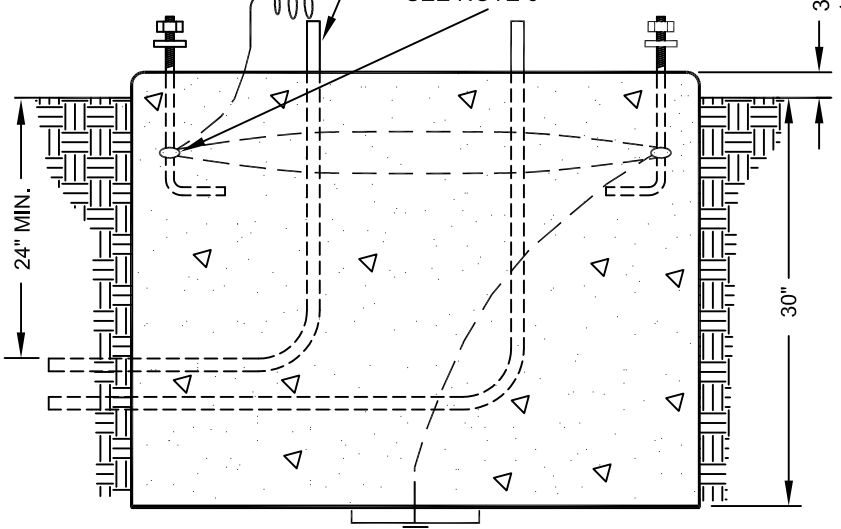

6' OF #4 AWG SINGLE STRAND BARE COPPER GROUNDING WIRE ABOVE FOUNDATION. CONNECT GROUNDING WIRE TO GROUNDING POINT.

60" MIN. (EASEMENT MAY BE NECESSARY)

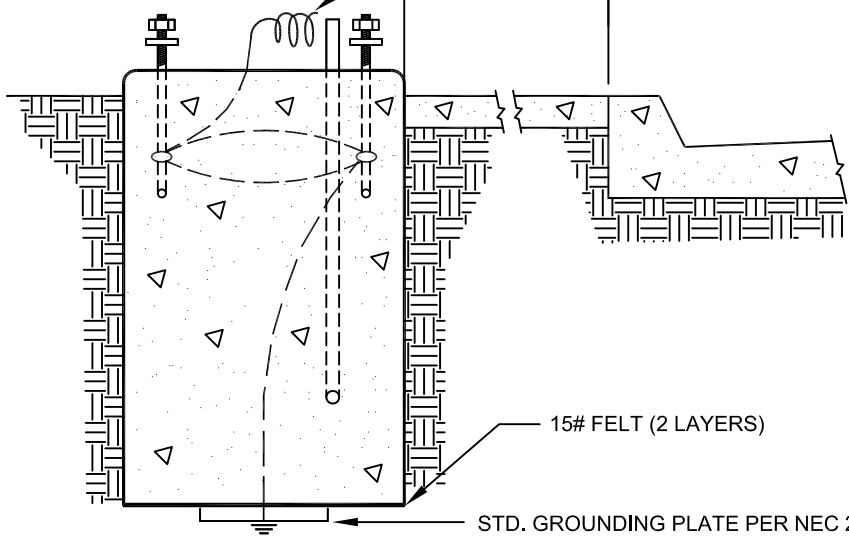

15# FELT (2 LAYERS)

STD. GROUNDING PLATE PER NEC 250-83

SPECIFICATION REFERENCE

UNIFORM STANDARD DRAWINGS
CLARK COUNTY AREA

TYPE "J" & "K" FOUNDATIONS

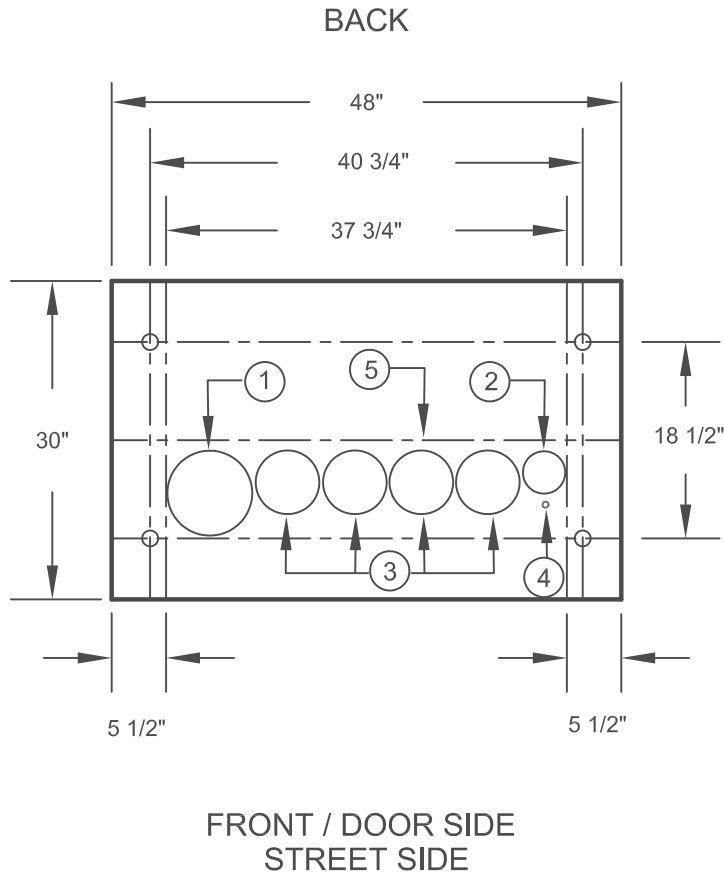

NOTES :

1. 3" OR 4" FIBER OR INTERCONNECT FROM TYPE 200 OR P-30 PULL BOX. REFER TO PLANS FOR INTERCONNECT/FIBER CONDUIT SIZE.
2. 2" CONDUIT FROM SERVICE PEDESTAL.
3. 3" CONDUITS FROM #7 TRAFFIC SIGNAL PULL BOX FOR SIGNAL POLES.
4. #4 SINGLE STRAND BARE COPPER WIRE SEE DRAWING 404.213 FOR DETAILS.
5. INSTALL CONDUITS 1" FRONT OF CENTER LINE.
6. REFER TO PLANS FOR ANY ADDITIONAL CONDUITS.

SPECIFICATION REFERENCE

UNIFORM STANDARD DRAWINGS
CLARK COUNTY AREA

CABINET CONDUIT LAYOUT
TYPE "J" & "K" FOUNDATIONS

DATE : 10-9-08

DWG. NO. 404.213A

SHEET 1 OF 1

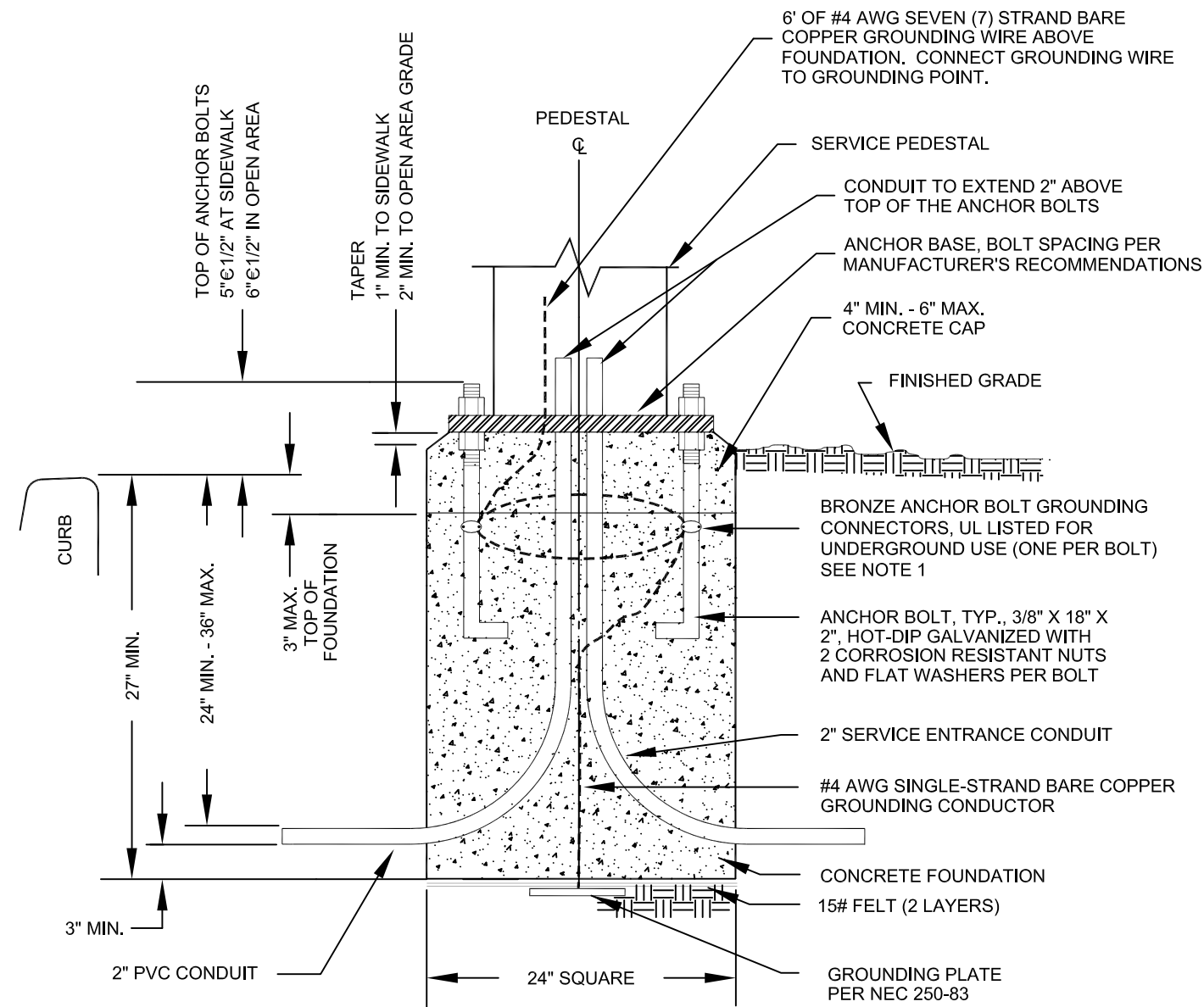

NOTES:

1. BARE COPPER GROUNDING CONDUCTOR SHALL BE LOOPED AROUND ANCHOR BOLTS ONE TIME AND CONNECTED TO EACH ANCHOR BOLT BEFORE CONTINUING DOWN TO THE GROUNDING PLATE.
2. CABINET COVERS SHALL BE PARALLEL WITH CURB.
3. IN AREAS WHERE R/W PERMITS, THE CONCRETE BASE SHALL BE PLACED AT THE BACK EDGE OF THE SIDEWALK.
4. CABINET COVERS SHALL OPEN TOWARDS THE STREET WHEN CABINETS ARE LOCATED AT BACK OF WALK. CABINET COVERS SHALL OPEN PARALLEL TO THE SIDEWALK FACING THE DIRECTION OF TRAFFIC WHEN LOCATED WITHIN THE SIDEWALK.

SPECIFICATION REFERENCE		UNIFORM STANDARD DRAWINGS CLARK COUNTY AREA					
501	PORTLAND CEMENT CONCRETE	SERVICE PEDESTAL FOUNDATION					
623	TRAFFIC SIGNALS & STREETLIGHTING						
		DATE	9-14-00	DWG. NO.	404.214	SHEET	1 OF 1

MOTOR: 1/125 HP-
3000 RPM NEMA CLASS
B INS. 0.65 AMPS AT
115 VAC.

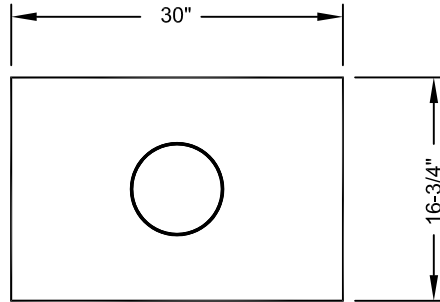

VENT FAN SPECIFICATION:
134 C.F.M. RATING AT .160"
OF WATER STATIC PRESSURE.

POLICE
PANEL

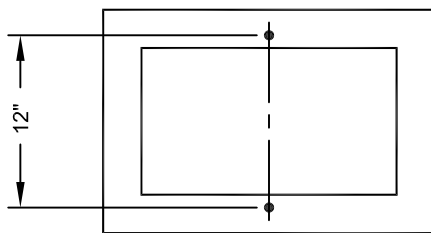
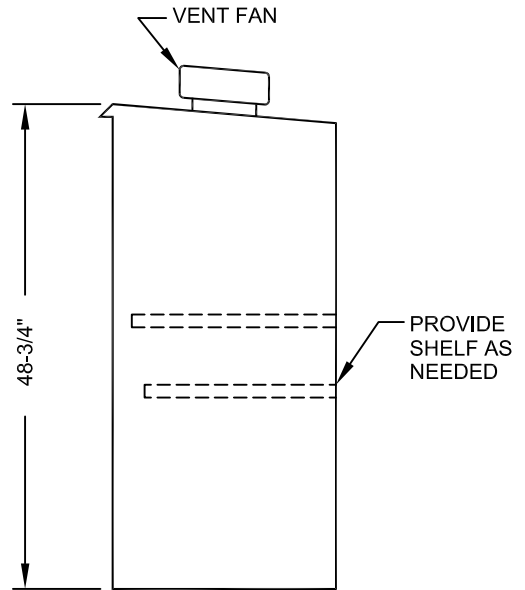
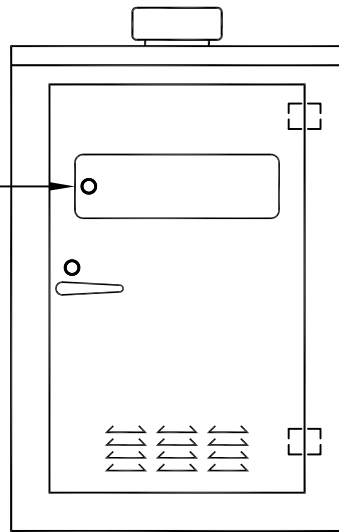

PLAN AT BASE

"M" CABINET

NOTES:

1. MATERIAL - 14 GA. SHEET STEEL, OR ALUMINUM EQUIVALENT.
2. PAINT OUTSIDE TWO COATS AND INSIDE TWO COATS WHITE ENAMEL OR AS APPROPRIATE.
3. DOOR SHALL LOCK AT THREE POINTS.
4. FOR FOUNDATION DETAILS AND ANCHOR BOLT LOCATION SEE DRAWING NO. 404.211.
5. INCLUDE 3/4" x 18" x 3" HOT-DIP GALVANIZED ANCHOR BOLTS WITH EACH CABINET.

SPECIFICATION REFERENCE

UNIFORM STANDARD DRAWINGS
CLARK COUNTY AREA

TYPE V
CABINET

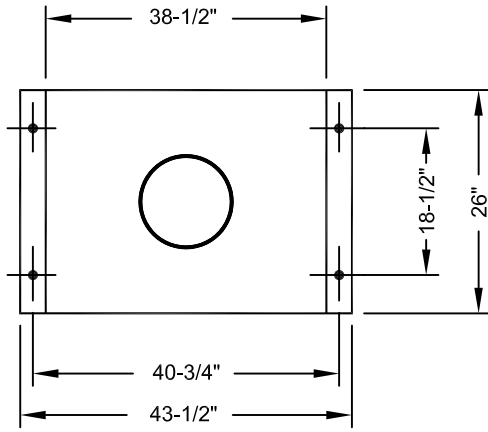

VENT FAN SPECIFICATION:
SEE STANDARD DRAWING
NO. 404.304

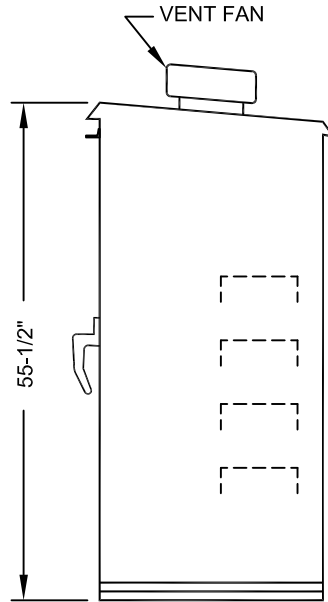
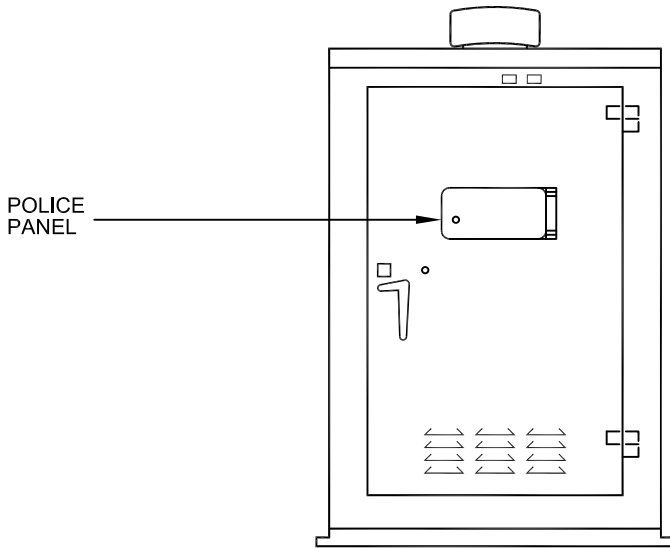

"P" CABINET

NOTES:

1. MATERIAL - 14 GA. SHEET STEEL, OR ALUMINUM EQUIVALENT.
2. PAINT OUTSIDE TWO COATS AND INSIDE TWO COATS WHITE ENAMEL OR AS APPROPRIATE.
3. SHELVES SHALL BE REMOVABLE AND ADJUSTABLE FOR VERTICAL SPACING.
4. DOOR SHALL LOCK AT THREE POINTS.
5. FOR FOUNDATION DETAILS AND ANCHOR BOLT LOCATION SEE DRAWING NO. 404.213.
6. INCLUDE 3/4" x 18" x 3" HOT-DIP GALVANIZED ANCHOR BOLTS WITH EACH CABINET.

SPECIFICATION REFERENCE

UNIFORM STANDARD DRAWINGS
CLARK COUNTY AREA

TYPE VI
CABINET

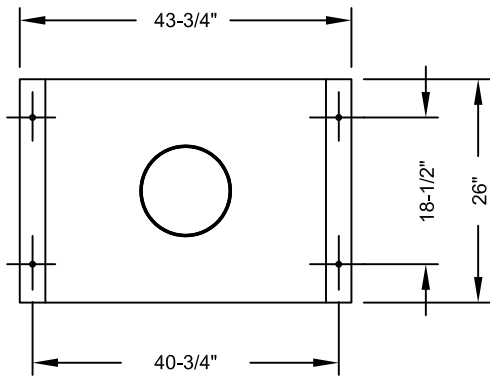

VENT FAN SPECIFICATION:
SEE STANDARD DRAWING
NO. 404.304

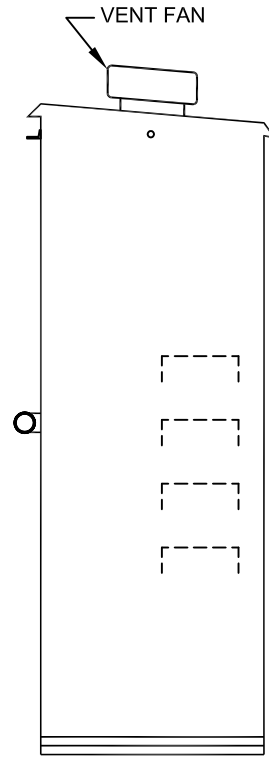
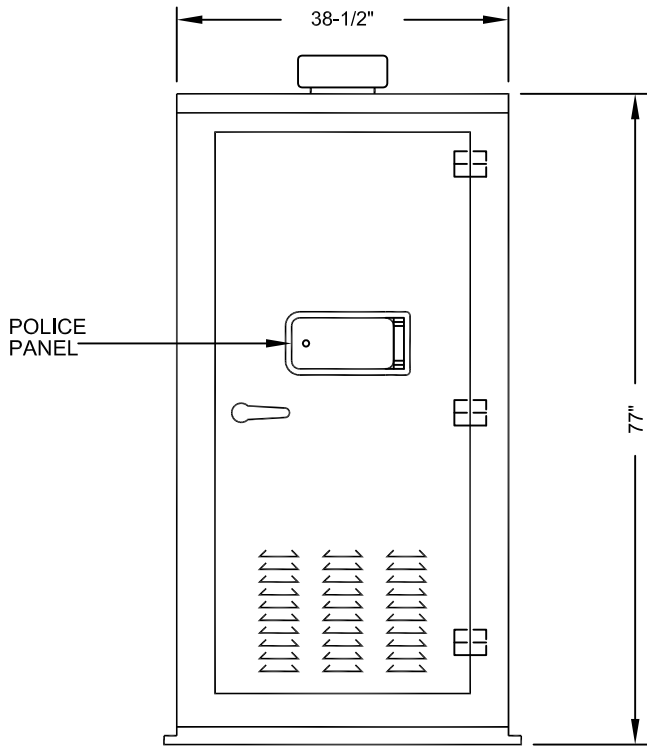

"R" CABINET

NOTES:

1. MATERIAL = 14 GA. SHEET STEEL, OR ALUMINUM EQUIVALENT.
2. PAINT OUTSIDE TWO COATS AND INSIDE TWO COATS WHITE ENAMEL OR AS APPROPRIATE.
3. FOR FOUNDATION DETAILS AND ANCHOR BOLT LOCATION SEE DRAWING NO. 404.213.
4. INCLUDE 3/4" x 18" x 3" HOT-DIP GALVANIZED ANCHOR BOLTS WITH EACH CABINET.

SPECIFICATION REFERENCE

UNIFORM STANDARD DRAWINGS
CLARK COUNTY AREA

TYPE VIII
CABINET

DATE 12-12-96

DWG. NO. 404.307

SHEET 1 OF 1

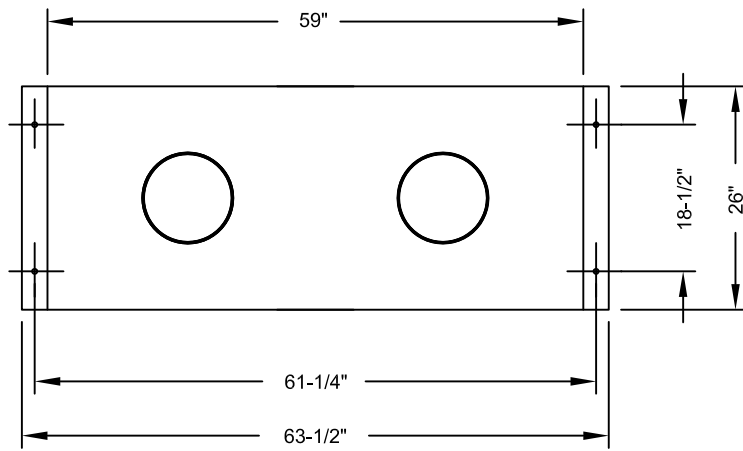

VENT FAN SPECIFICATION:
SEE STANDARD DRAWING
NO. 404.304

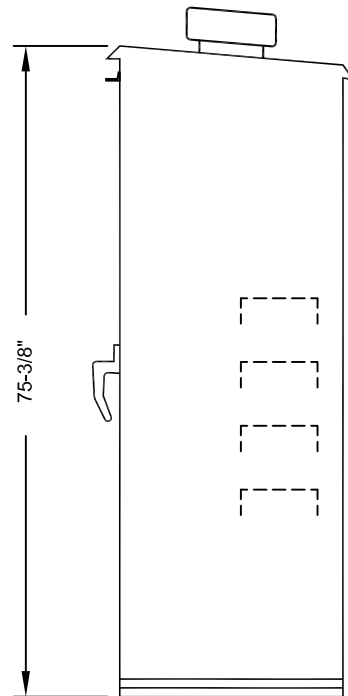
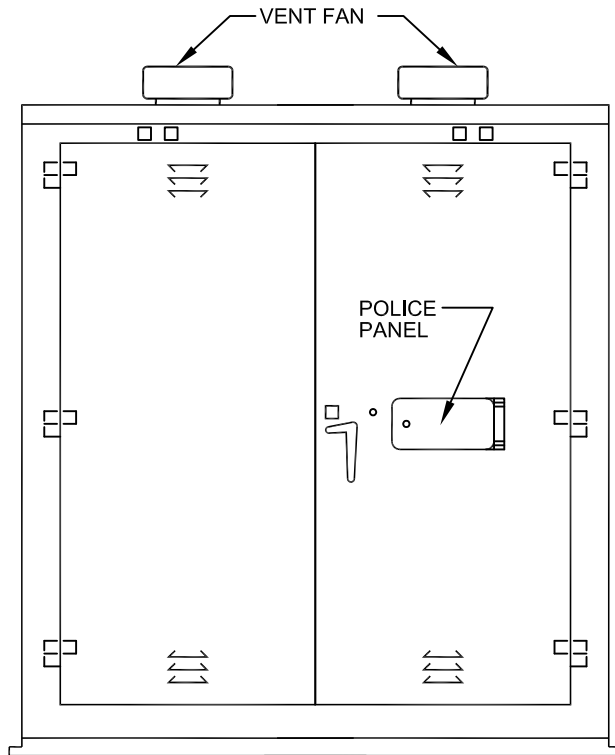

"RR" CABINET

NOTES:

1. MATERIAL - 14 GA. SHEET STEEL,
OR ALUMINUM EQUIVALENT.
2. PAINT OUTSIDE TWO COATS AND INSIDE
TWO COATS WHITE ENAMEL OR AS
APPROPRIATE.
3. FOUNDATION DETAILS SHALL BE SPECIFIED
ON THE SIGNAL CONSTRUCTION PLANS.
4. INCLUDE 3/4" x 18" x 3" HOT-DIP GALVANIZED
ANCHOR BOLTS WITH EACH CABINET.

SPECIFICATION REFERENCE

UNIFORM STANDARD DRAWINGS
CLARK COUNTY AREA

TYPE IX
CABINET

FLASHING BEACON CONTROLLER CABINET

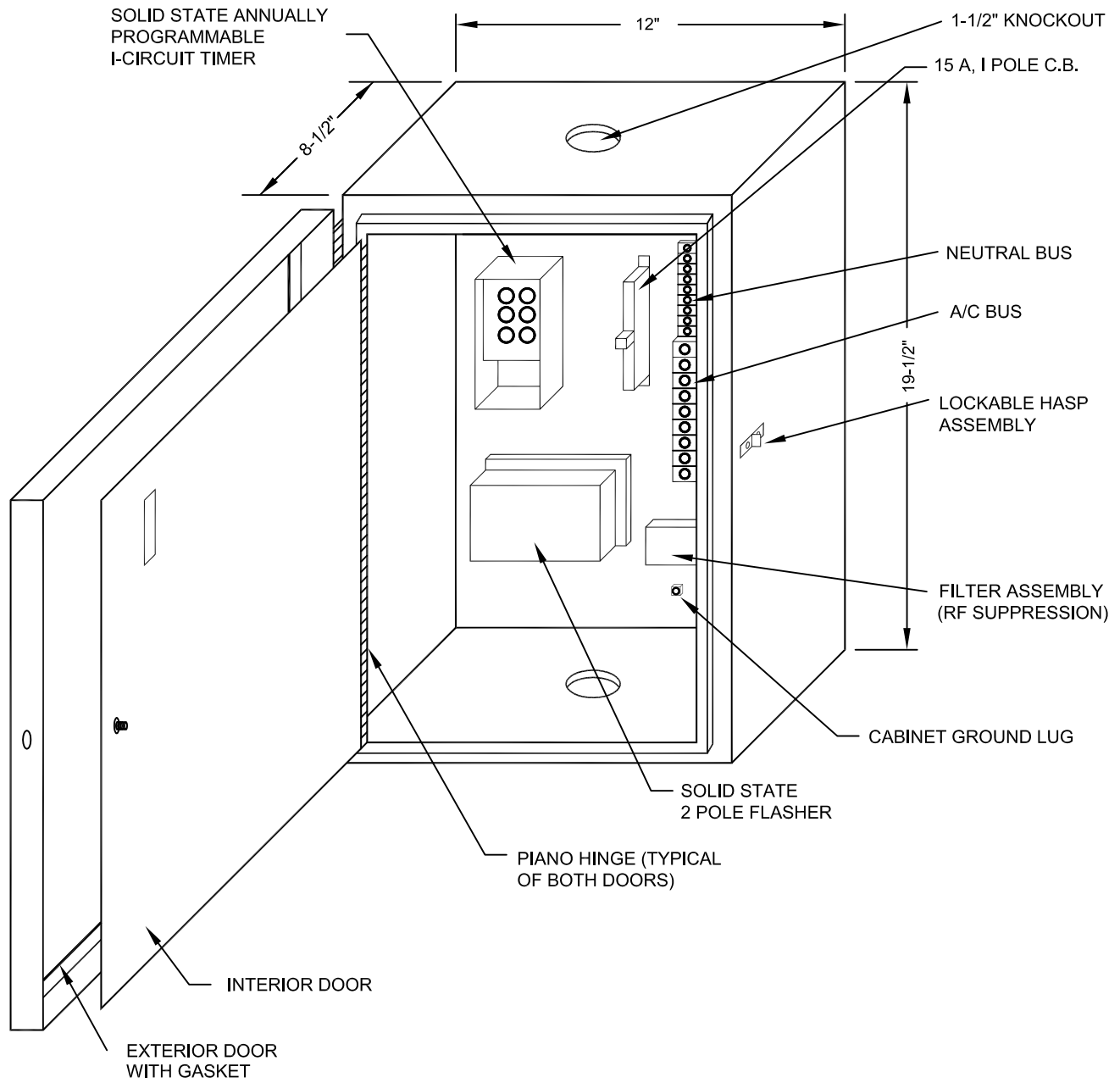

NOTES:

1. CONSTRUCT FROM MINIMUM 12-GUAGE STEEL.
2. THE TIMER SHALL BE RTC-AP21 OR EQUIVALENT.

SPECIFICATION REFERENCE

UNIFORM STANDARD DRAWINGS
CLARK COUNTY AREA

FLASHING BEACON
CONTROLLER CABINET

WIRING DIAGRAM FOR FLASHING BEACON TIMER CONTROLLED OPERATION

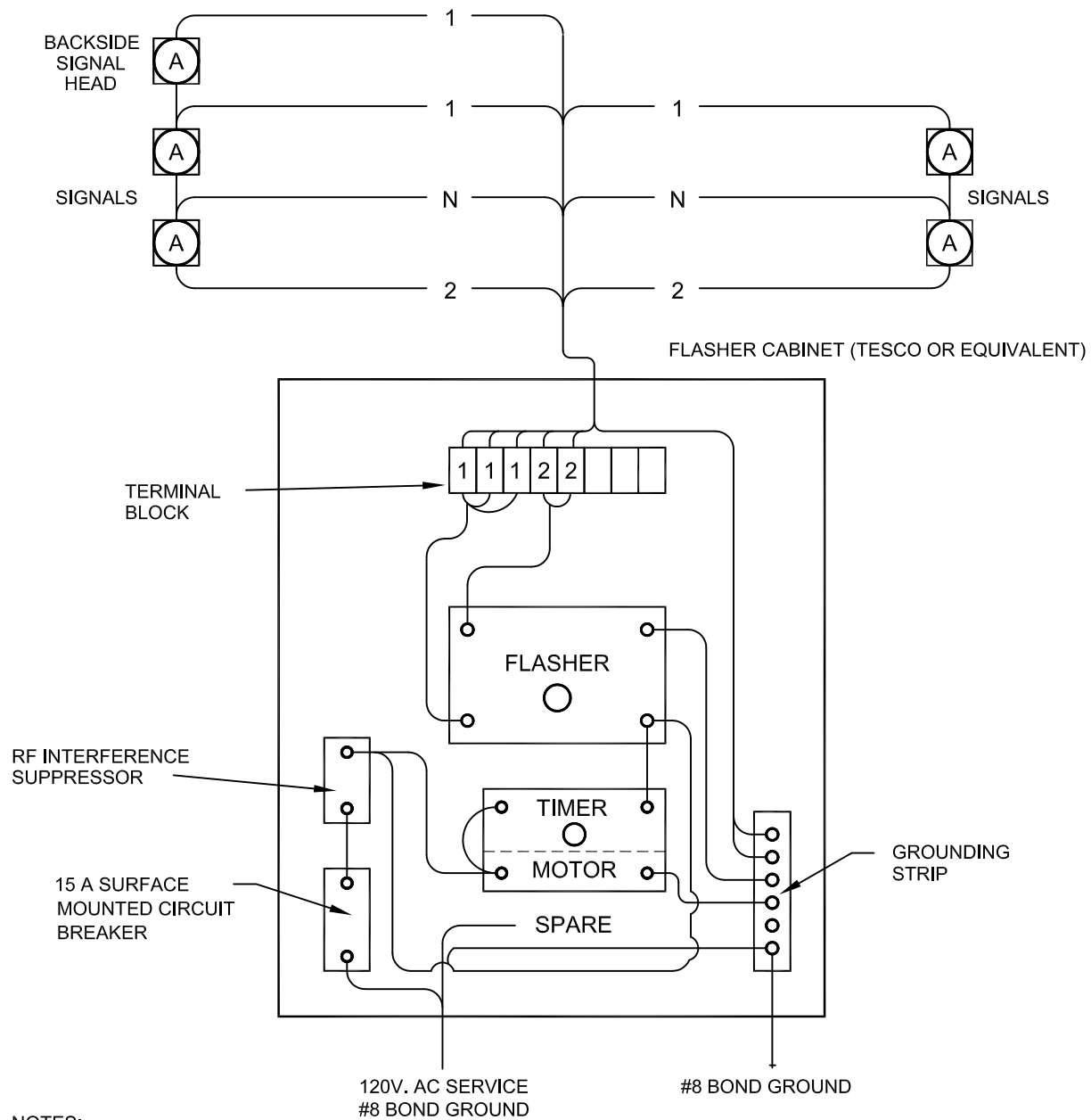

NOTES:

1. ALL WIRING INSIDE THE CABINET SHALL BE #14 THW.
2. ALL FIELD WIRE TO THE SIGNAL SHALL BE #14 SOLID COPPER.
3. THE SERVICE WIRE SHALL BE 2-#4 THW & 1-#6 THW. PROVIDE #10 PIGTAIL FOR CONNECTION TO BREAKER.
4. THE TIMER SHALL BE RTC-AP21 OR EQUIVALENT.
5. TWO POLE SOLID STATE FLASHER.
6. THERE SHALL BE A 1" MINIMUM CLEARANCE BETWEEN INDIVIDUAL COMPONENTS.
7. ALL SERVICE POINTS SHALL BE AS FOR STREET LIGHTING.
8. FLASHING PATTERN OF LIGHTS TO BE SPECIFIED BY THE ENTITY.

SPECIFICATION REFERENCE

UNIFORM STANDARD DRAWINGS
CLARK COUNTY AREA

WIRING DIAGRAM FOR FLASHING BEACON
TIMER CONTROLLED OPERATION

LUMINAIRE PIPE TENON AS REQUIRED

THIS ARM DESIGN FOR 35' MTG. HEIGHT ONLY

15' ARM LENGTH

11 GA. ROUND TAPERED ARM

REMOVABLE POLE TOP

PROVIDE WIRE GUIDE INTO SHAFT

LENGTH "L" SEE NOTES ON SIGNAL PLANS OR CONTRACT

4-1/2" X 7" (MIN. INSIDE DIM.) HANDHOLE AND COVER (LOCATED 180° OPPOSITE MAST ARM)

90° OR 95° AS PER SPECIFICATION

SEE NOTE 4

NOTES:

1. ALL POLES TO BE HOT-DIP GALVANIZED BY MANUFACTURER OR PRIME PAINTED BY MANUFACTURER AND FINISH PAINTED BY CONTRACTOR PER SPECIFICATIONS AND AS REQUIRED BY THE ENTITY.
2. LOW BIDDER MUST SUPPLY SHOP DRAWING FOR DESIGN APPROVAL BEFORE CONTRACT CAN BE AWARDED.
3. FOR OTHER DETAILS SEE DRAWING NO. 404.406 SHTS. 2 & 6.
4. INSTALL A BACKFACING LIGHT ON BACK OF OUTERMOST LIGHT, INDICATING THE SPEED LIMIT MESSAGE IS IN OPERATION.
5. HANDHOLE COVERS SHALL BE MOUNTED WITH TAMPER-RESISTANT SCREWS.
6. MULTI-SIDED POLE AND MAST ARM WITH A MINIMUM OF 16 SIDES MAY BE USED IF DIRECTED BY THE ENTITY ENGINEER.

BACK VIEW OF SIGN

17' MIN.

FOR "F" TYPE FOUNDATION SEE DRAWING NO. 404.206

4-1/2" X 7" (MIN. INSIDE DIM.) HANDHOLE AND COVER (SHALL FACE AWAY FROM ONCOMING TRAFFIC)

BASE COVER

18'-6"

3 GA., 30" ROUND TAPERED STEEL SHAFT

SPECIFICATION REFERENCE

UNIFORM STANDARD DRAWINGS
CLARK COUNTY AREA

SCHOOL FLASHING SIGN ON
POLE WITH LUMINAIRE

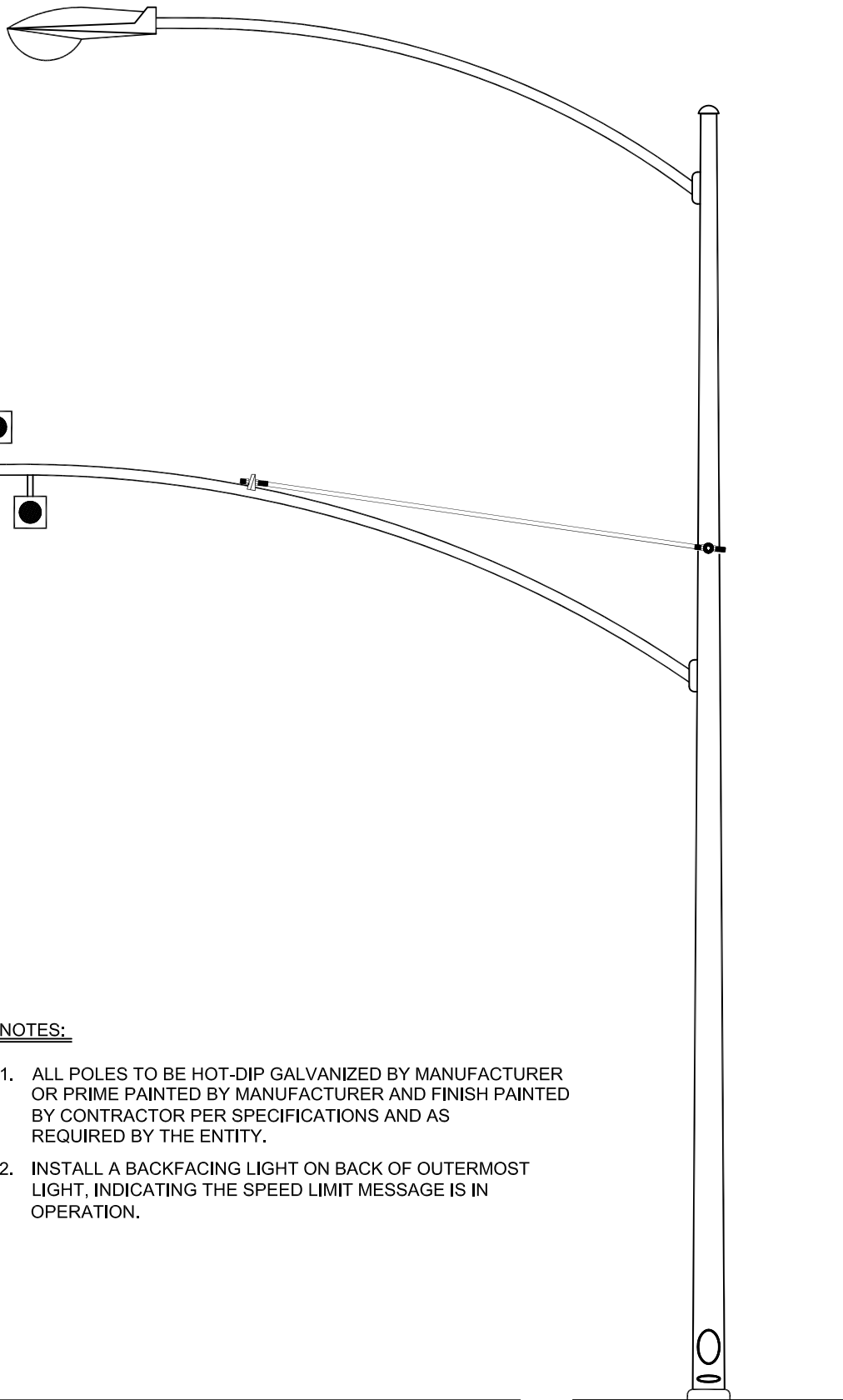

NOTES:

1. ALL POLES TO BE HOT-DIP GALVANIZED BY MANUFACTURER OR PRIME PAINTED BY MANUFACTURER AND FINISH PAINTED BY CONTRACTOR PER SPECIFICATIONS AND AS REQUIRED BY THE ENTITY.
2. INSTALL A BACKFACING LIGHT ON BACK OF OUTERMOST LIGHT, INDICATING THE SPEED LIMIT MESSAGE IS IN OPERATION.

17' MIN.

SEE NOTE 4

SPECIFICATION REFERENCE

UNIFORM STANDARD DRAWINGS
CLARK COUNTY AREA

SCHOOL FLASHING SIGN ON
TYPE-III POLE

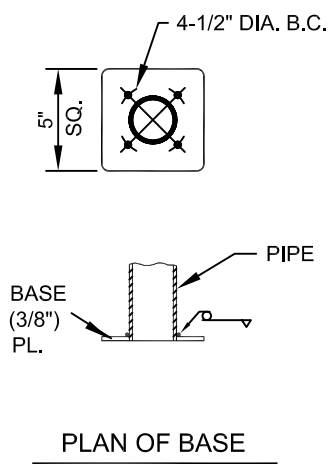
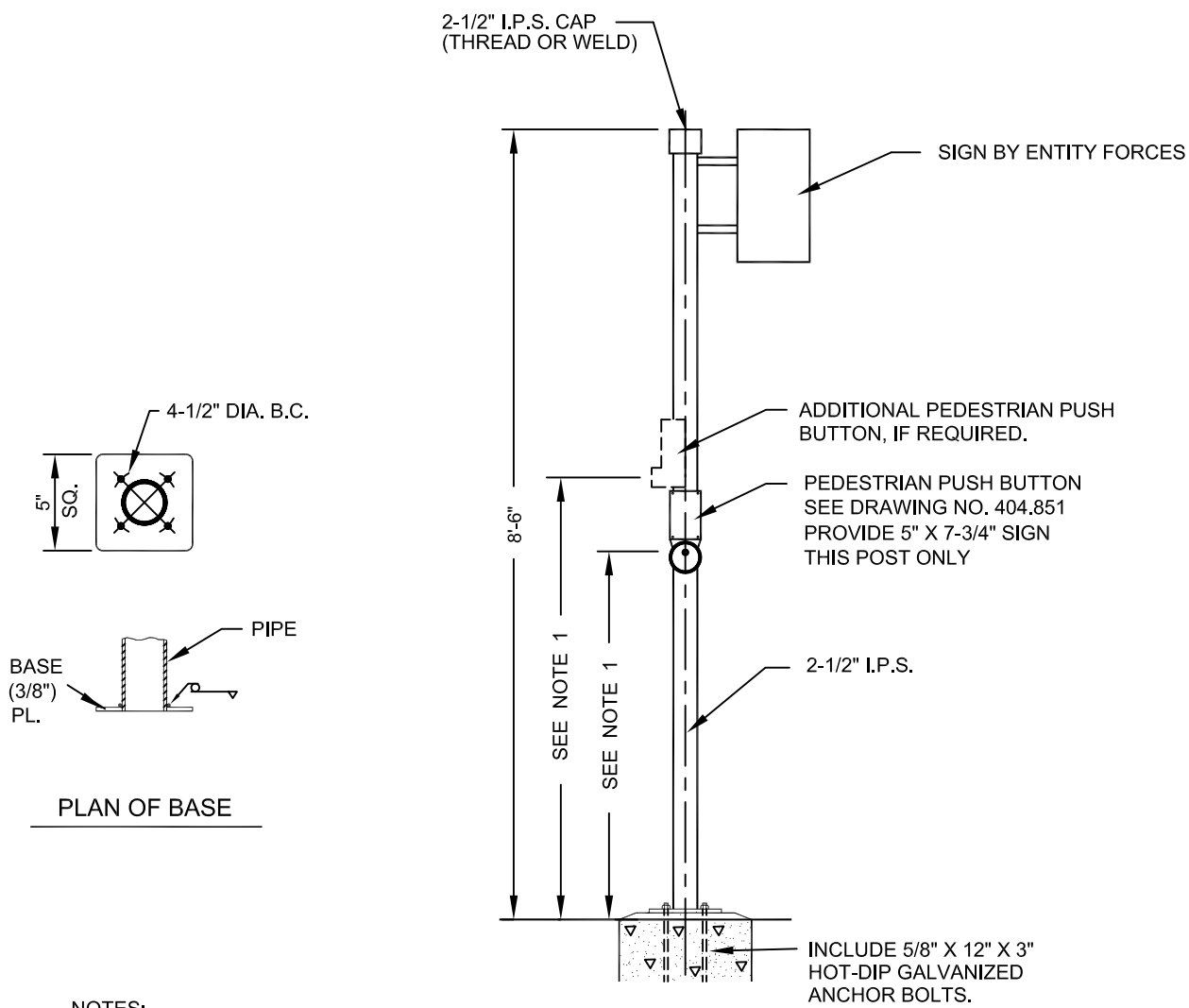

NOTES:

1. PEDESTRIAN PUSH BUTTON SHALL NOT BE LOCATED MORE THAN 24" FROM THE BACK OF WALK. IF DISTANCE FROM BACK OF WALK TO PUSH BUTTON IS 20" TO 24", THE BUTTON SHALL BE LOCATED AT A MAXIMUM HEIGHT OF 44" FROM THE SURFACE OF THE WALK; OTHERWISE, THE MAXIMUM HEIGHT SHALL BE 48".
2. THE FORCE REQUIRED TO ACTIVATE CONTROL SHALL BE NO GREATER THAN 5 LB.
3. POST SHALL BE HOT-DIP GALVANIZED BY MANUFACTURER OR PRIME PAINTED BY MANUFACTURER AND FINISH PAINTED BY CONTRACTOR PER SPECIFICATIONS AND AS REQUIRED BY THE ENTITY.

FOR TYPE "A" FOUNDATION SEE DRAWING NO. 404.201

SPECIFICATION REFERENCE		UNIFORM STANDARD DRAWINGS CLARK COUNTY AREA	
		PEDESTRIAN PUSH BUTTON POST FOR SPECIAL SIGN (8'-6" HIGH)	
DATE	12-12-96	DWG. NO.	404.401
SHEET			1 OF 2

Effective 01/01/09 - 06/30/09

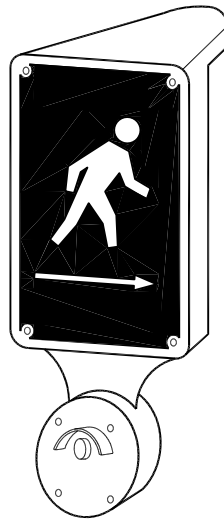

PEDESTRIAN PUSHBUTTON
FOR 2 1/2" POSTTOP MOUNTING

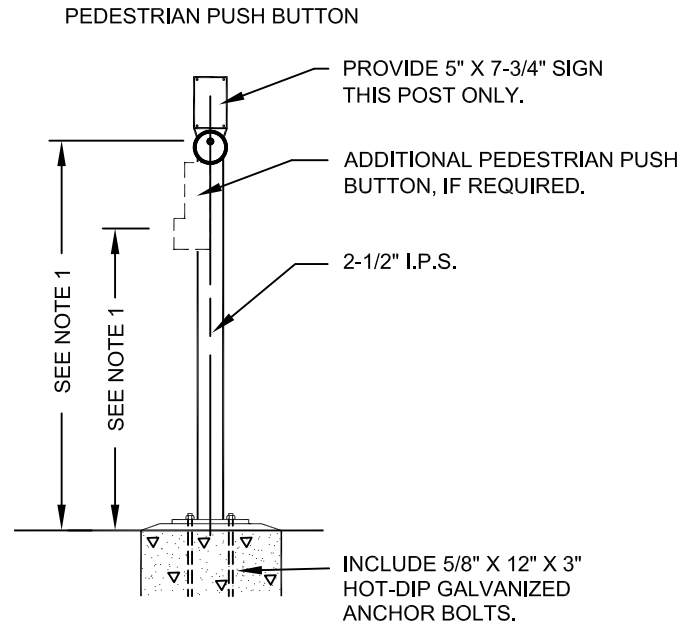
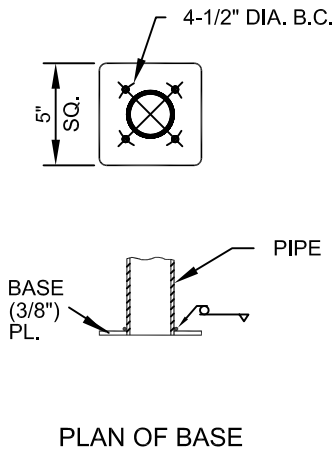

NOTES:

1. PEDESTRIAN PUSH BUTTON SHALL NOT BE LOCATED MORE THAN 24" FROM THE BACK OF WALK. IF DISTANCE FROM BACK OF WALK TO PUSH BUTTON IS 20" TO 24", THE BUTTON SHALL BE LOCATED AT A MAXIMUM HEIGHT OF 44" FROM THE SURFACE OF THE WALK; OTHERWISE, THE MAXIMUM HEIGHT SHALL BE 48".
2. THE FORCE REQUIRED TO ACTIVATE CONTROL SHALL BE NO GREATER THAN 5 LB.
3. POST SHALL BE HOT-DIP GALVANIZED BY MANUFACTURER OR PRIME PAINTED BY MANUFACTURER AND FINISH PAINTED BY CONTRACTOR PER SPECIFICATIONS AND AS REQUIRED BY THE ENTITY.

FOR TYPE "A" FOUNDATION SEE DRAWING NO. 404.201

SPECIFICATION REFERENCE		UNIFORM STANDARD DRAWINGS CLARK COUNTY AREA			
		PEDESTRIAN PUSH BUTTON POST FOR 2 1/2 POSTTOP MOUNTING			
DATE	12-12-96	DWG. NO.	404.401	SHEET	2 OF 2

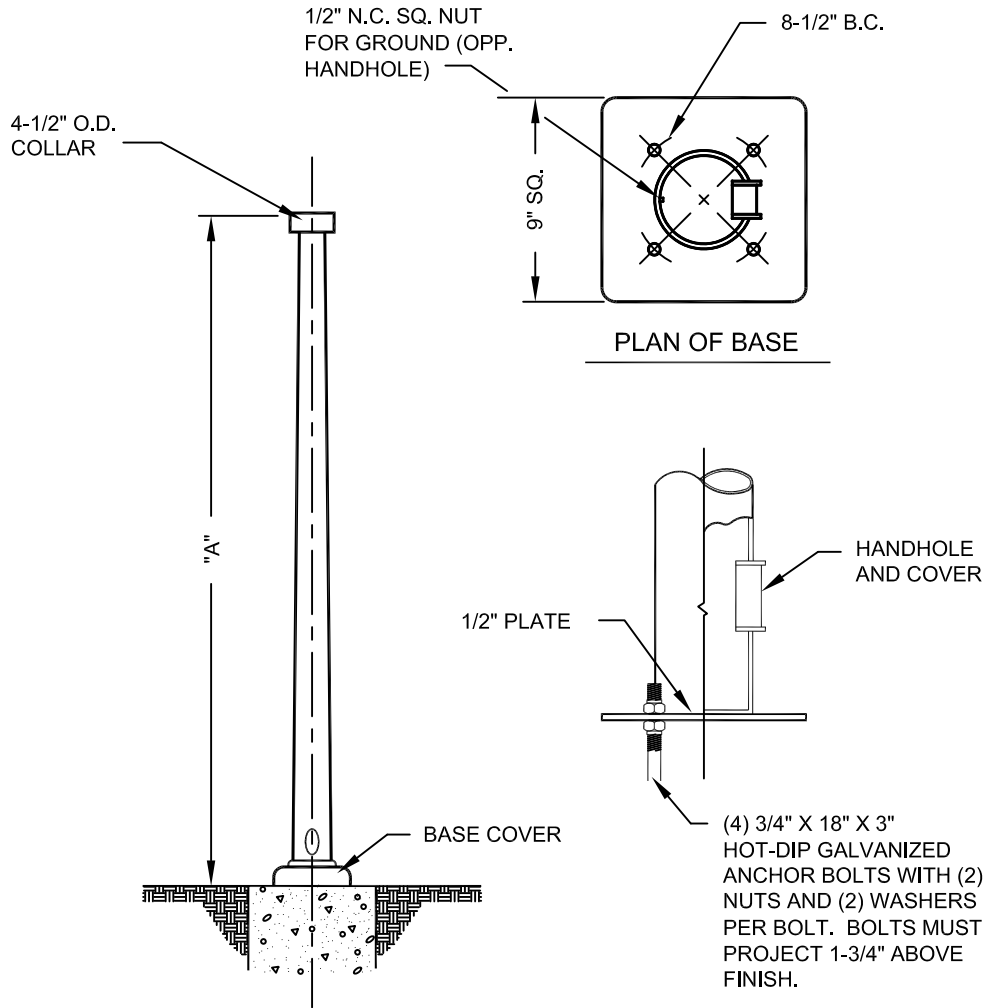

POLE TYPE	"A" NOM.	SHAFT SIZE	
1-A	10'-0"	11 GA. 5.5" X 4.1" X 10'-0"	NEAR RIGHTS & ISL. POLES
1-B	7'-0"	11 GA. 5.5" X 4.1" X 7'-0"	PED. HEADS & BUTTON ONLY

NOTES:

1. ALL POLES TO BE HOT-DIP GALVANIZED BY MANUFACTURER OR PRIME PAINTED BY MANUFACTURER AND FINISH PAINTED BY CONTRACTOR PER SPECIFICATIONS AND AS REQUIRED BY THE ENTITY.
2. HANDHOLE COVERS SHALL BE MOUNTED WITH TAMPER-RESISTANT SCREWS.
3. PEDESTRIAN PUSH BUTTON SHALL NOT BE LOCATED MORE THAN 24" FROM THE BACK OF WALK. IF DISTANCE FROM BACK OF WALK TO PUSH BUTTON IS 20" TO 24", THE BUTTON SHALL BE LOCATED A MAXIMUM OF 44" FROM THE SURFACE OF THE WALK; OTHERWISE, THE MAXIMUM HEIGHT SHALL BE 48".

FOR TYPE "C" FOUNDATION SEE DRAWING NO. 404.203.

SPECIFICATION REFERENCE		UNIFORM STANDARD DRAWINGS CLARK COUNTY AREA					
		SIGNAL STANDARD TYPE 1-A, 1-B					
		DATE	12-12-96	DWG. NO.	404.402	SHEET	1 OF 1

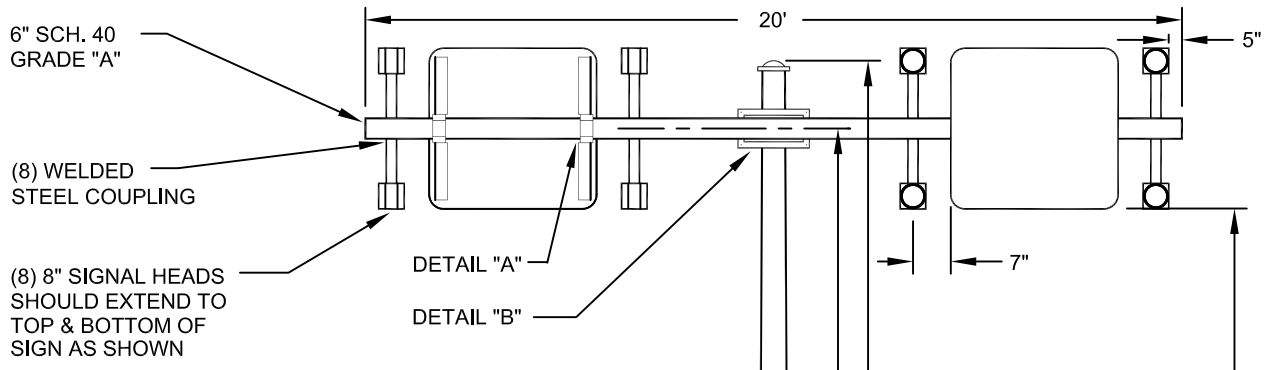

(8) 8" SIGNAL HEADS SHOULD EXTEND TO TOP & BOTTOM OF SIGN AS SHOWN

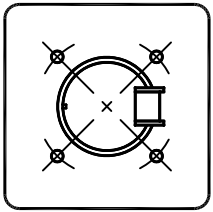

PLAN OF BASE

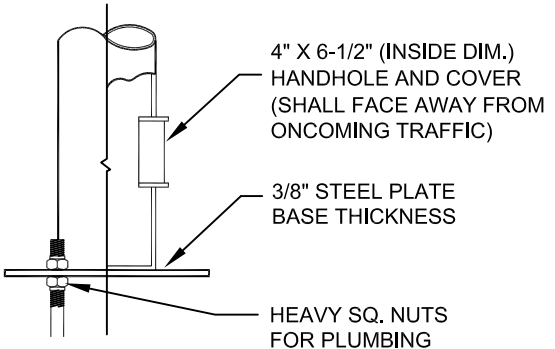

NOTES:

1. DRILL 1" HOLES IN STEEL PIPE WHERE 1-1/2" STEEL COUPLINGS ARE TO BE.
2. POLE TO BE HOT-DIP GALVANIZED BY MANUFACTURER OR PRIME PAINTED BY MANUFACTURER AND FINISH PAINTED BY CONTRACTOR PER SPECIFICATIONS AND AS REQUIRED BY THE ENTITY.
3. HANDHOLE COVERS SHALL BE MOUNTED WITH TAMPER-RESISTANT SCREWS.

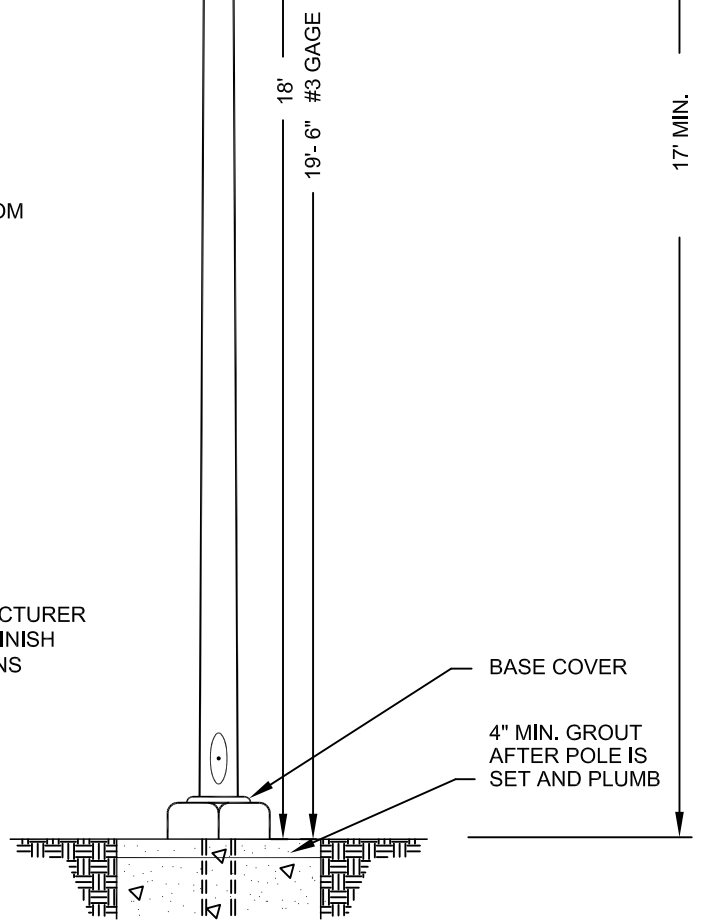

FOR TYPE "G" FOUNDATION SEE DRAWING NO. 404.207

SPECIFICATION REFERENCE

UNIFORM STANDARD DRAWINGS
CLARK COUNTY AREA

SIGN POST WITH
SCHOOL SIGN MOUNTED

Effective 01/01/09 - 06/30/09

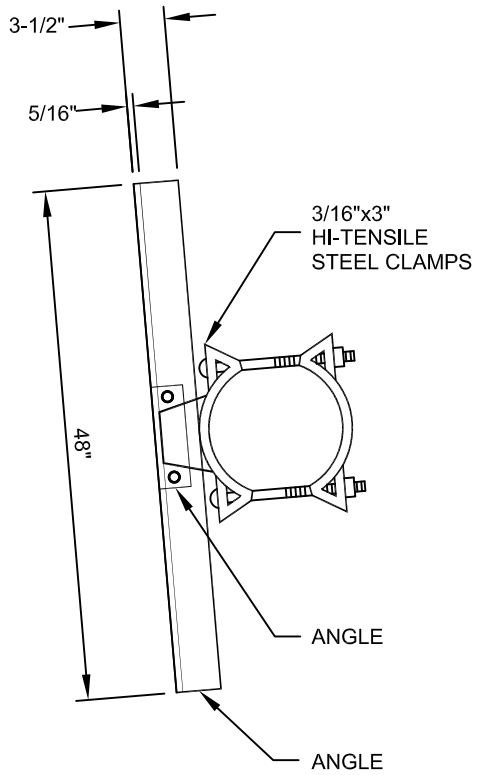

DETAIL A

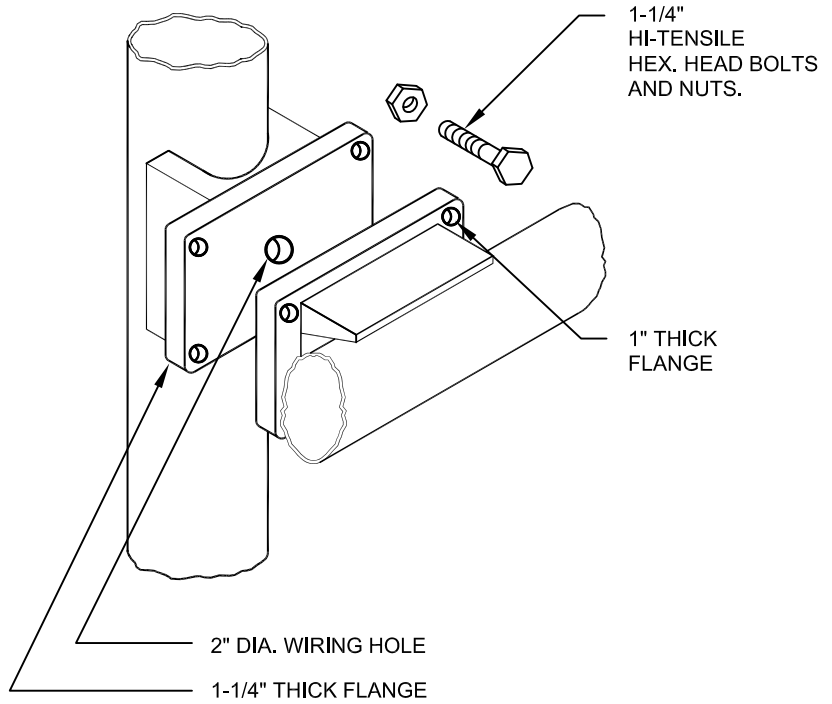

DETAIL B

SPECIFICATION REFERENCE

UNIFORM STANDARD DRAWINGS
CLARK COUNTY AREA

SIGN POST WITH
SCHOOL SIGN MOUNTED
DETAILS

DATE

DWG. NO.

404.403

SHEET

2 OF 2

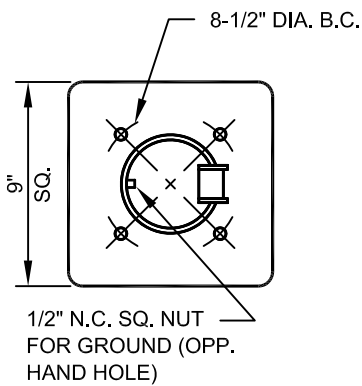

PLAN OF BASE

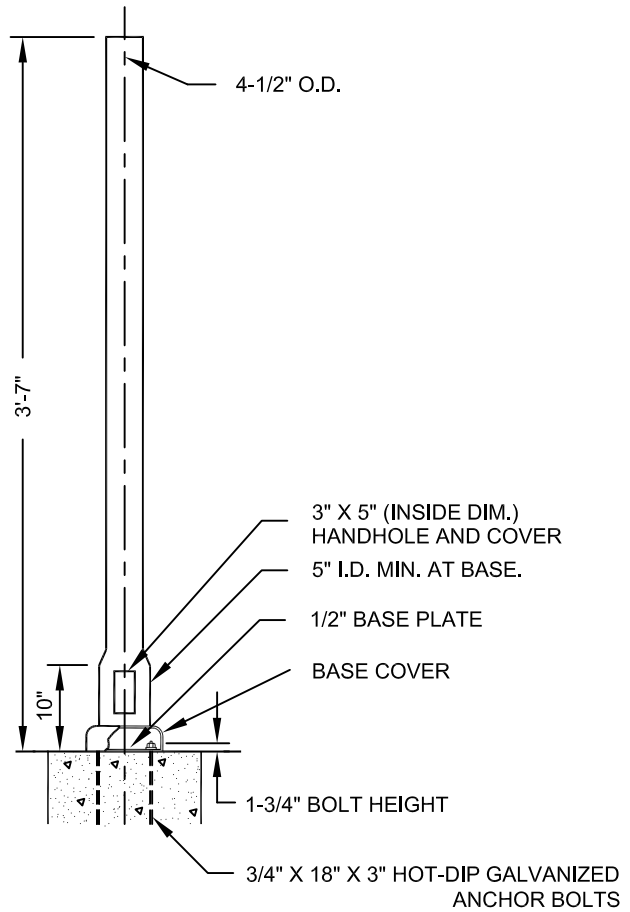

NOTES:

1. ALL POLES TO BE HOT-DIP GALVANIZED BY MANUFACTURER OR PRIME PAINTED BY MANUFACTURER AND FINISH BY PAINTED BY CONTRACTOR PER SPECIFICATIONS AND AS REQUIRED BY THE ENTITY.
2. HANDHOLE COVERS SHALL BE MOUNTED WITH TAMPER-RESISTANT SCREWS.

FOR TYPE "C" FOUNDATION SEE DRAWING NO. 404.203.

SPECIFICATION REFERENCE		UNIFORM STANDARD DRAWINGS CLARK COUNTY AREA			
		PEDESTAL FOR CONTROLLER CABINETS			
DATE	12-12-96	DWG. NO.	404.405	SHEET	1 OF 1

LUMINAIRE MOUNTING HEIGHT MEASURED TO CENTER OF END OF MAST ARM

LUMINAIRE ARM DATA				
ARM SPAN "L" (FT)	FIXED END DIA. (IN)	FREE END DIA. (IN)	GAUGE	LUMINAIRE MOUNTING HEIGHT
6	3.42	2.38	11	32'-0"
8	3.75	2.38	11	33'-3"
10	4.16	2.38	11	35'-0"
12	4.52	2.38	11	36'-6"
15	4.95	2.38	11	37'-0"

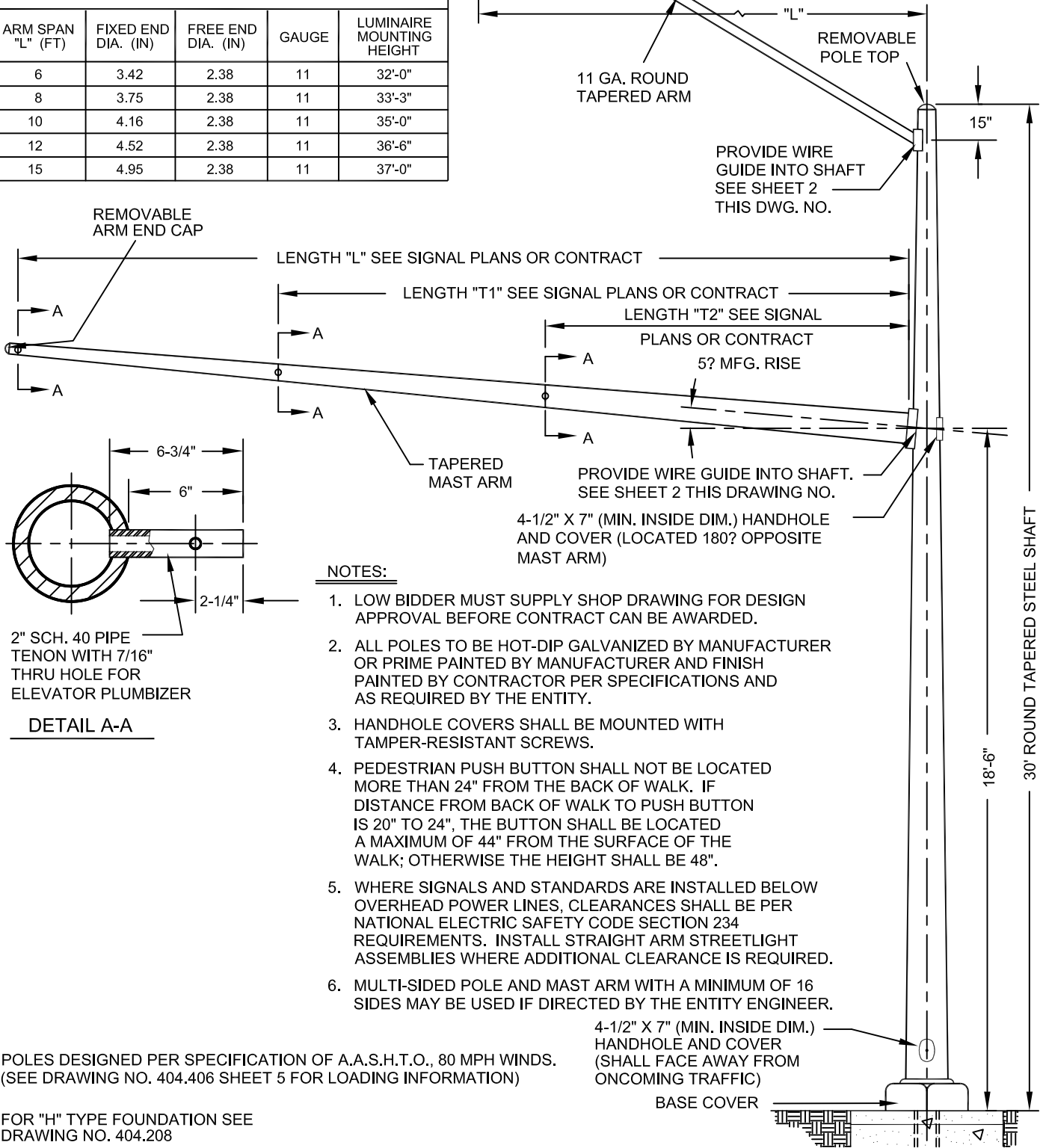

NOTES:

1. LOW BIDDER MUST SUPPLY SHOP DRAWING FOR DESIGN APPROVAL BEFORE CONTRACT CAN BE AWARDED.
2. ALL POLES TO BE HOT-DIP GALVANIZED BY MANUFACTURER OR PRIME PAINTED BY MANUFACTURER AND FINISH PAINTED BY CONTRACTOR PER SPECIFICATIONS AND AS REQUIRED BY THE ENTITY.
3. HANDHOLE COVERS SHALL BE MOUNTED WITH TAMPER-RESISTANT SCREWS.
4. PEDESTRIAN PUSH BUTTON SHALL NOT BE LOCATED MORE THAN 24" FROM THE BACK OF WALK. IF DISTANCE FROM BACK OF WALK TO PUSH BUTTON IS 20" TO 24", THE BUTTON SHALL BE LOCATED A MAXIMUM OF 44" FROM THE SURFACE OF THE WALK; OTHERWISE THE HEIGHT SHALL BE 48".
5. WHERE SIGNALS AND STANDARDS ARE INSTALLED BELOW OVERHEAD POWER LINES, CLEARANCES SHALL BE PER NATIONAL ELECTRIC SAFETY CODE SECTION 234 REQUIREMENTS. INSTALL STRAIGHT ARM STREETLIGHT ASSEMBLIES WHERE ADDITIONAL CLEARANCE IS REQUIRED.
6. MULTI-SIDED POLE AND MAST ARM WITH A MINIMUM OF 16 SIDES MAY BE USED IF DIRECTED BY THE ENTITY ENGINEER.

POLES DESIGNED PER SPECIFICATION OF A.A.S.H.T.O., 80 MPH WINDS. (SEE DRAWING NO. 404.406 SHEET 5 FOR LOADING INFORMATION)

FOR "H" TYPE FOUNDATION SEE DRAWING NO. 404.208

SPECIFICATION REFERENCE

UNIFORM STANDARD DRAWINGS
CLARK COUNTY AREA

TYPE XX-30'-0"
SIGNAL & LUMINAIRE POLE
(45' OR LESS MAST ARMS)

Effective 01/01/09 - 06/30/09

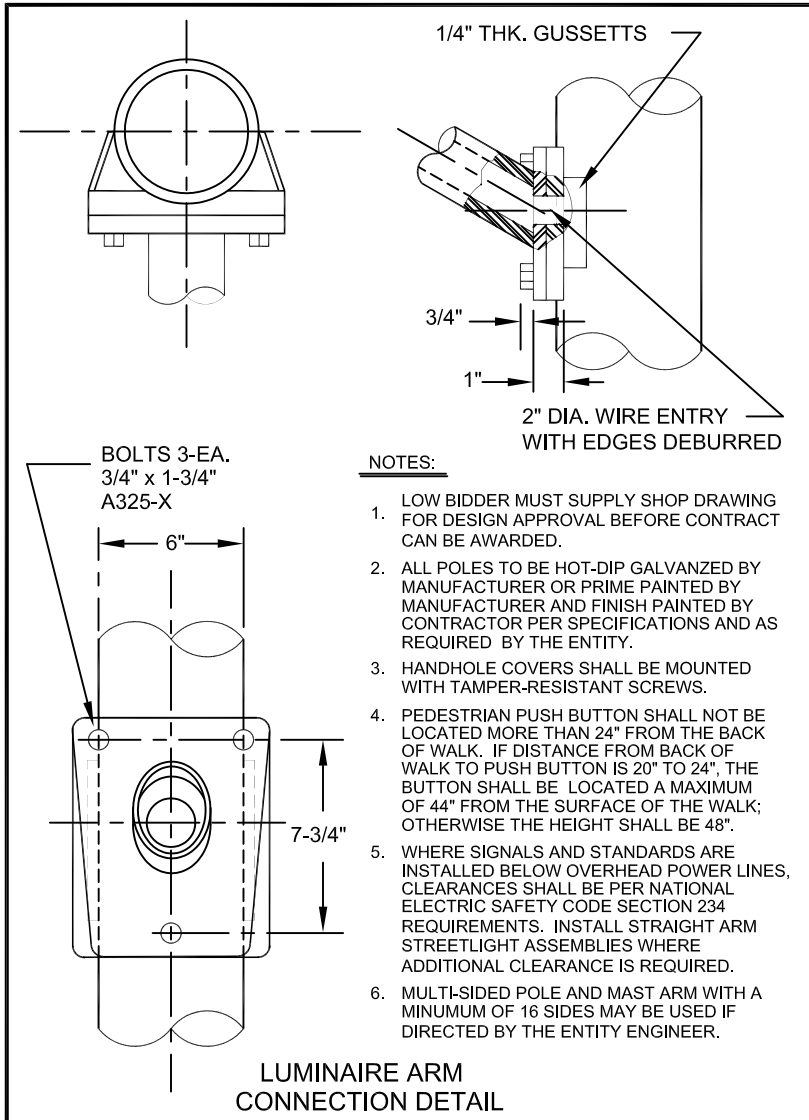

- NOTES:**
1. LOW BIDDER MUST SUPPLY SHOP DRAWING FOR DESIGN APPROVAL BEFORE CONTRACT CAN BE AWARDED.
 2. ALL POLES TO BE HOT-DIP GALVANIZED BY MANUFACTURER OR PRIME PAINTED BY MANUFACTURER AND FINISH PAINTED BY CONTRACTOR PER SPECIFICATIONS AND AS REQUIRED BY THE ENTITY.
 3. HANDHOLE COVERS SHALL BE MOUNTED WITH TAMPER-RESISTANT SCREWS.
 4. PEDESTRIAN PUSH BUTTON SHALL NOT BE LOCATED MORE THAN 24" FROM THE BACK OF WALK. IF DISTANCE FROM BACK OF WALK TO PUSH BUTTON IS 20" TO 24", THE BUTTON SHALL BE LOCATED A MAXIMUM OF 44" FROM THE SURFACE OF THE WALK; OTHERWISE THE HEIGHT SHALL BE 48".
 5. WHERE SIGNALS AND STANDARDS ARE INSTALLED BELOW OVERHEAD POWER LINES, CLEARANCES SHALL BE PER NATIONAL ELECTRIC SAFETY CODE SECTION 234 REQUIREMENTS. INSTALL STRAIGHT ARM STREETLIGHT ASSEMBLIES WHERE ADDITIONAL CLEARANCE IS REQUIRED.
 6. MULTI-SIDED POLE AND MAST ARM WITH A MINIMUM OF 16 SIDES MAY BE USED IF DIRECTED BY THE ENTITY ENGINEER.

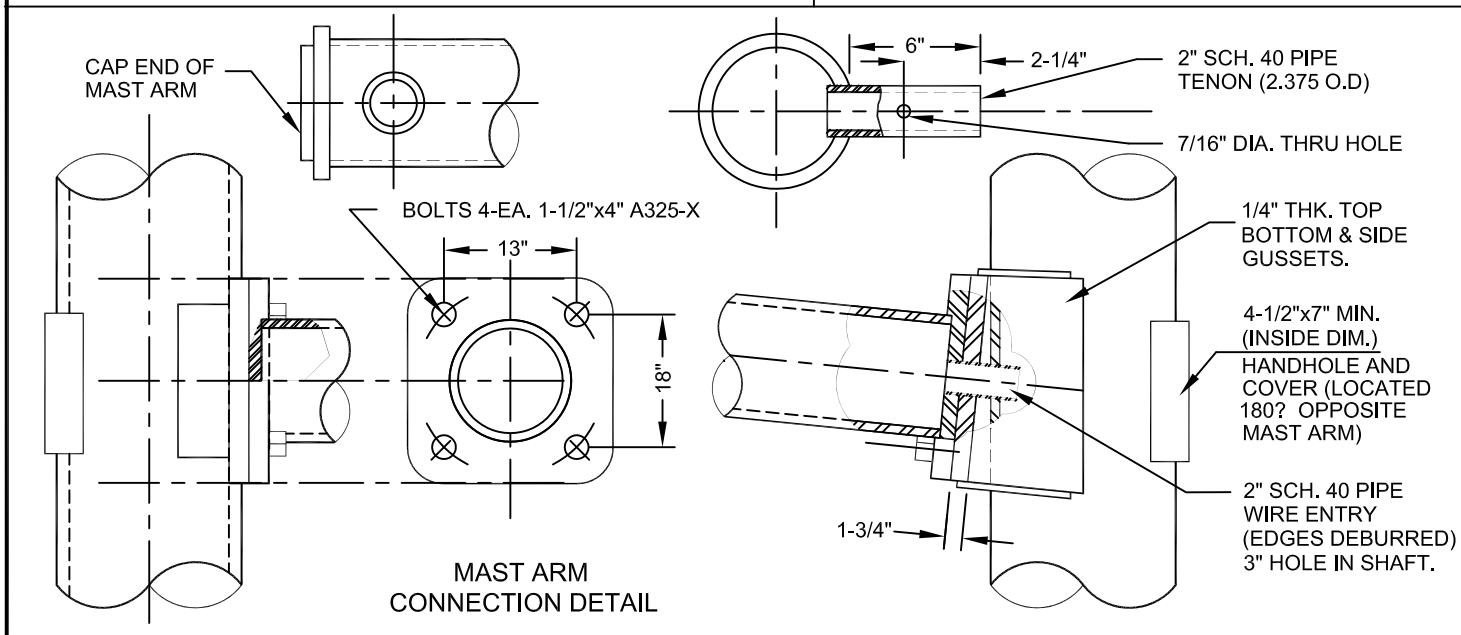
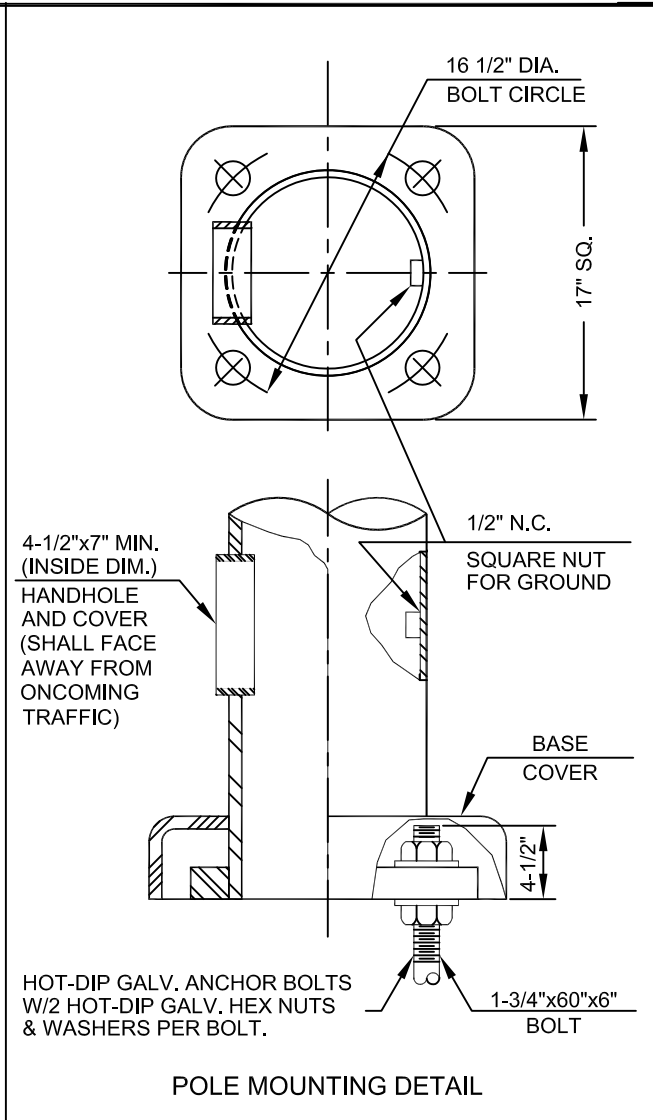

Effective 01/01/09 - 06/30/09

SPECIFICATION REFERENCE		UNIFORM STANDARD DRAWINGS CLARK COUNTY AREA			
		TYPE XX - 30'-0"			
		SIGNAL & LUMINAIRE POLE DETAILS			
DATE	9-14-06	DWG. NO.	404.406	SHEET	2 OF 6

LUMINAIRE ARM DATA				
ARM SPAN "L" (FT)	FIXED END DIA. (IN)	FREE END DIA. (IN)	GAUGE	LUMINAIRE MOUNTING HEIGHT
6	3.42	2.38	11	32'-0"
8	3.75	2.38	11	33'-3"
10	4.16	2.38	11	35'-0"
12	4.52	2.38	11	36'-6"
15	4.95	2.38	11	37'-0"

LUMINAIRE MOUNTING HEIGHT MEASURED TO CENTER OF END OF MAST ARM

"L"
11 GA. ROUND TAPERED ARM

REMOVABLE POLE TOP

15"
PROVIDE WIRE GUIDE INTO SHAFT SEE SHEET 4 THIS DRAWING NO.

REMOVABLE ARM END CAP

LENGTH "L" SEE SIGNAL PLANS OR CONTRACT

LENGTH "T1" SEE SIGNAL PLANS OR CONTRACT

LENGTH "T2" SEE SIGNAL PLANS OR CONTRACT

5? MFG. RISE

TAPERED MAST ARM

PROVIDE WIRE GUIDE INTO SHAFT. SEE SHEET 4 THIS DRAWING NO.

4-1/2" X 7" (MIN. INSIDE DIM.) HANDHOLE AND COVER (LOCATED 180° OPPOSITE MAST ARM)

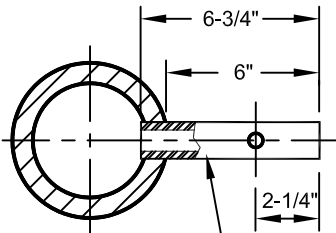

2" SCH. 40 PIPE TENON WITH 7/16" THRU HOLE FOR ELEVATOR PLUMBIZER

DETAIL A-A

NOTES:

1. LOW BIDDER MUST SUPPLY SHOP DRAWING FOR DESIGN APPROVAL BEFORE CONTRACT CAN BE AWARDED.
2. ALL POLES TO BE HOT-DIP GALVANIZED BY MANUFACTURER OR PRIME PAINTED BY MANUFACTURER AND FINISH PAINTED BY CONTRACTOR PER SPECIFICATIONS AND AS REQUIRED BY THE ENTITY.
3. HANDHOLE COVERS SHALL BE MOUNTED WITH TAMPER-RESISTANT SCREWS.
4. PEDESTRIAN PUSH BUTTON SHALL NOT BE LOCATED MORE THAN 24" FROM THE BACK OF WALK. IF DISTANCE FROM BACK OF WALK TO PUSH BUTTON IS 20" TO 24", THE BUTTON SHALL BE LOCATED A MAXIMUM OF 44" FROM THE SURFACE OF THE WALK; OTHERWISE THE HEIGHT SHALL BE 48".
5. WHERE SIGNALS AND STANDARDS ARE INSTALLED BELOW OVERHEAD POWER LINES, CLEARANCES SHALL BE PER NATIONAL ELECTRIC SAFETY CODE SECTION 234 REQUIREMENTS. INSTALL STRAIGHT ARM STREETLIGHT ASSEMBLIES WHERE ADDITIONAL CLEARANCE IS REQUIRED.
6. MULTI-SIDED POLE AND MAST ARM WITH A MINIMUM OF 16 SIDES MAY BE USED IF DIRECTED BY THE ENTITY ENGINEER.

POLES DESIGNED PER SPECIFICATION OF A.A.S.H.T.O., 80 MPH WINDS. (SEE DRAWING NO. 404.406 SHEET 5 FOR LOADING INFORMATION)

FOR "L" TYPE FOUNDATION SEE DRAWING NO. 404.209

4-1/2" X 7" (MIN. INSIDE DIM.) HANDHOLE AND COVER (SHALL FACE AWAY FROM ONCOMING TRAFFIC)

BASE COVER

18'-6"
30' ROUND TAPERED STEEL SHAFT

SPECIFICATION REFERENCE

UNIFORM STANDARD DRAWINGS
CLARK COUNTY AREA

TYPE XX - A - 30'-0"
SIGNAL & LUMINAIRE POLE
(50' THRU 60' MAST ARMS)

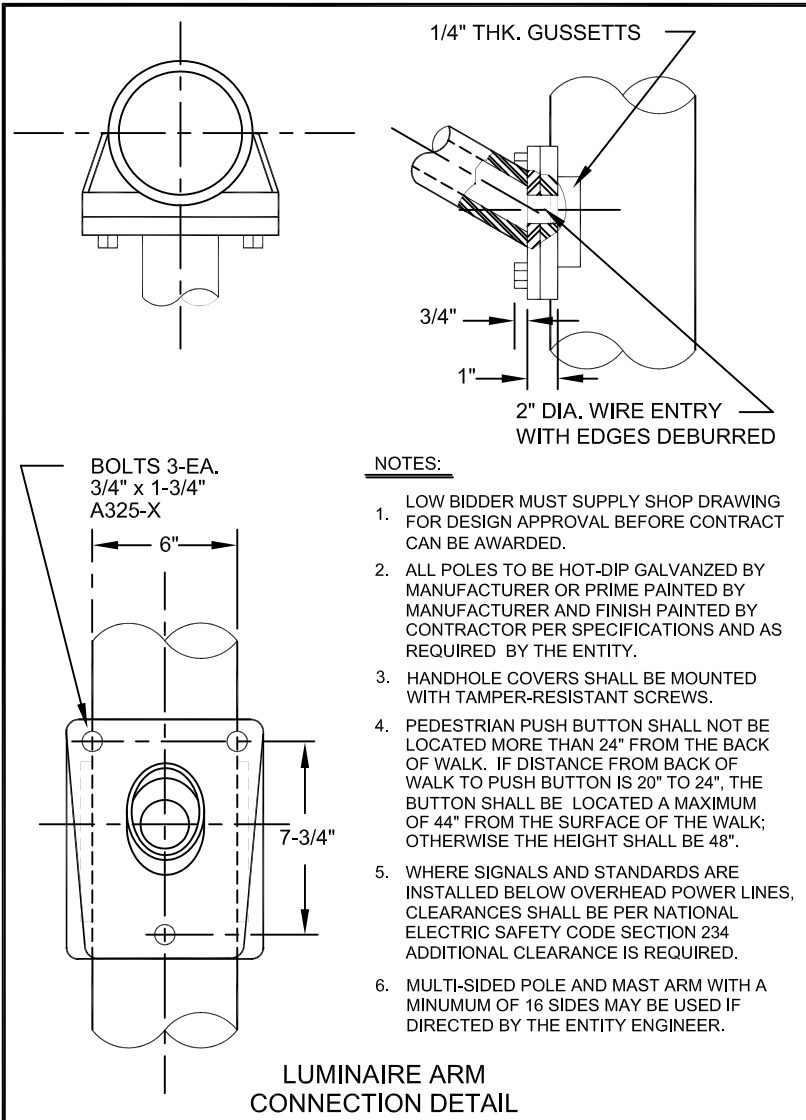

- NOTES:**
1. LOW BIDDER MUST SUPPLY SHOP DRAWING FOR DESIGN APPROVAL BEFORE CONTRACT CAN BE AWARDED.
 2. ALL POLES TO BE HOT-DIP GALVANIZED BY MANUFACTURER OR PRIME PAINTED BY MANUFACTURER AND FINISH PAINTED BY CONTRACTOR PER SPECIFICATIONS AND AS REQUIRED BY THE ENTITY.
 3. HANDHOLE COVERS SHALL BE MOUNTED WITH TAMPER-RESISTANT SCREWS.
 4. PEDESTRIAN PUSH BUTTON SHALL NOT BE LOCATED MORE THAN 24" FROM THE BACK OF WALK. IF DISTANCE FROM BACK OF WALK TO PUSH BUTTON IS 20" TO 24", THE BUTTON SHALL BE LOCATED A MAXIMUM OF 44" FROM THE SURFACE OF THE WALK; OTHERWISE THE HEIGHT SHALL BE 48".
 5. WHERE SIGNALS AND STANDARDS ARE INSTALLED BELOW OVERHEAD POWER LINES, CLEARANCES SHALL BE PER NATIONAL ELECTRIC SAFETY CODE SECTION 234. ADDITIONAL CLEARANCE IS REQUIRED.
 6. MULTI-SIDED POLE AND MAST ARM WITH A MINIMUM OF 16 SIDES MAY BE USED IF DIRECTED BY THE ENTITY ENGINEER.

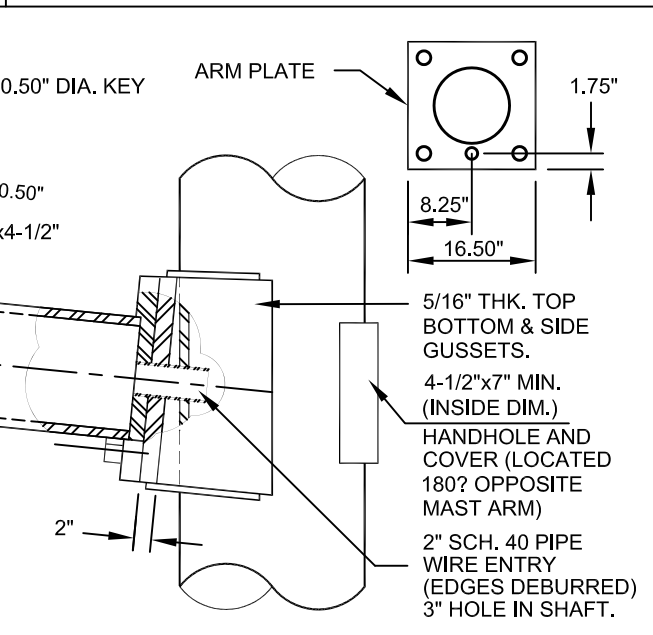
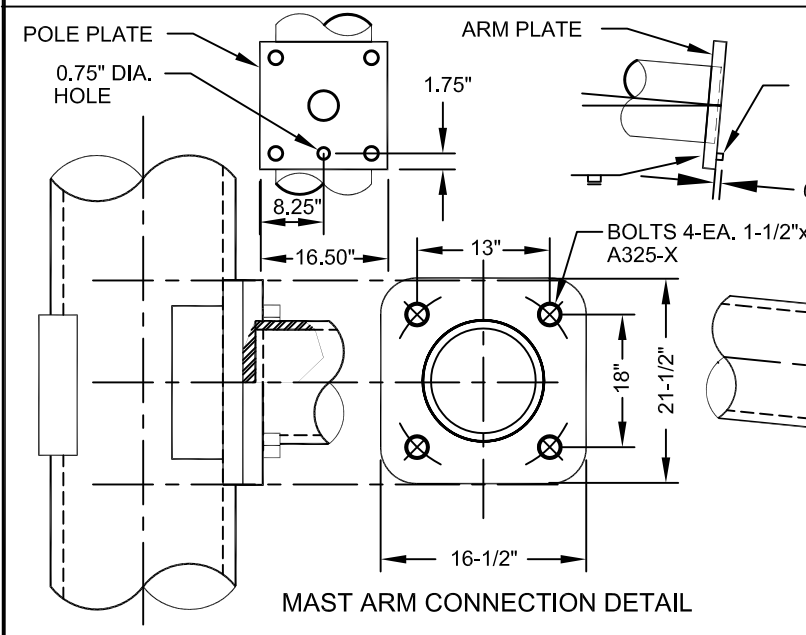
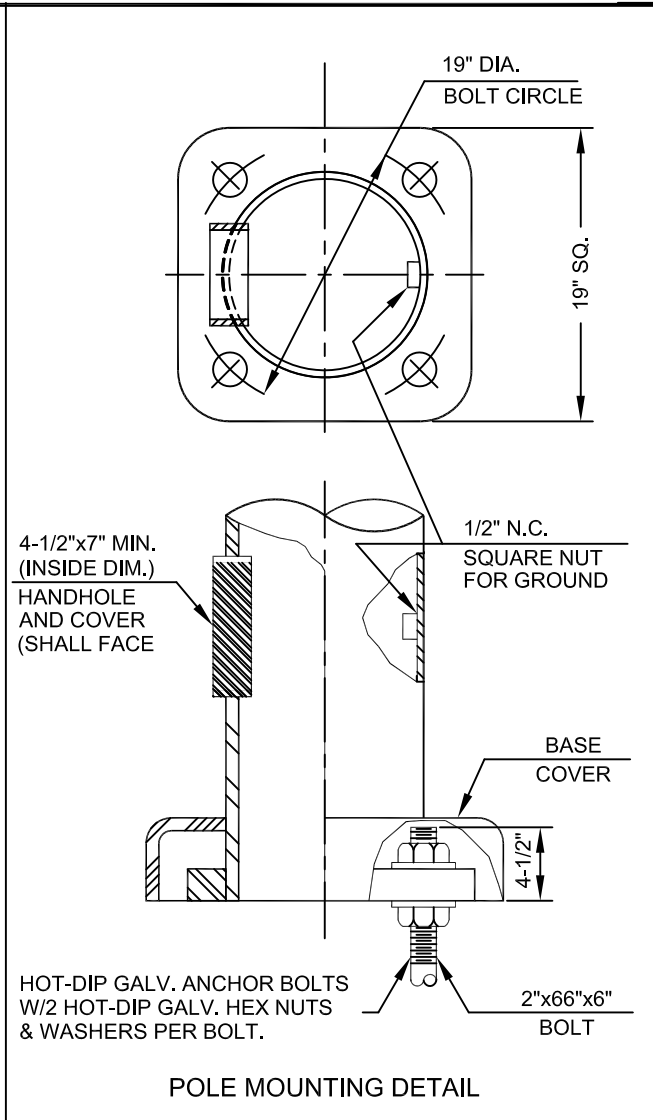

Effective 01/01/09 - 06/30/09

SPECIFICATION REFERENCE		UNIFORM STANDARD DRAWINGS CLARK COUNTY AREA			
		TYPE XX - A - 30'-0" (50' THRU 60' MAST ARMS) SIGNAL & LUMINAIRE POLE DETAILS			
DATE	9-14-06	DWG. NO.	404.406	SHEET	4 OF 6

SPECIFICATION REFERENCE	

UNIFORM STANDARD DRAWINGS CLARK COUNTY AREA				
LOADING INFORMATION				
DATE	7-8-93	DWG. NO.	404.406	SHEET
				5 OF 6

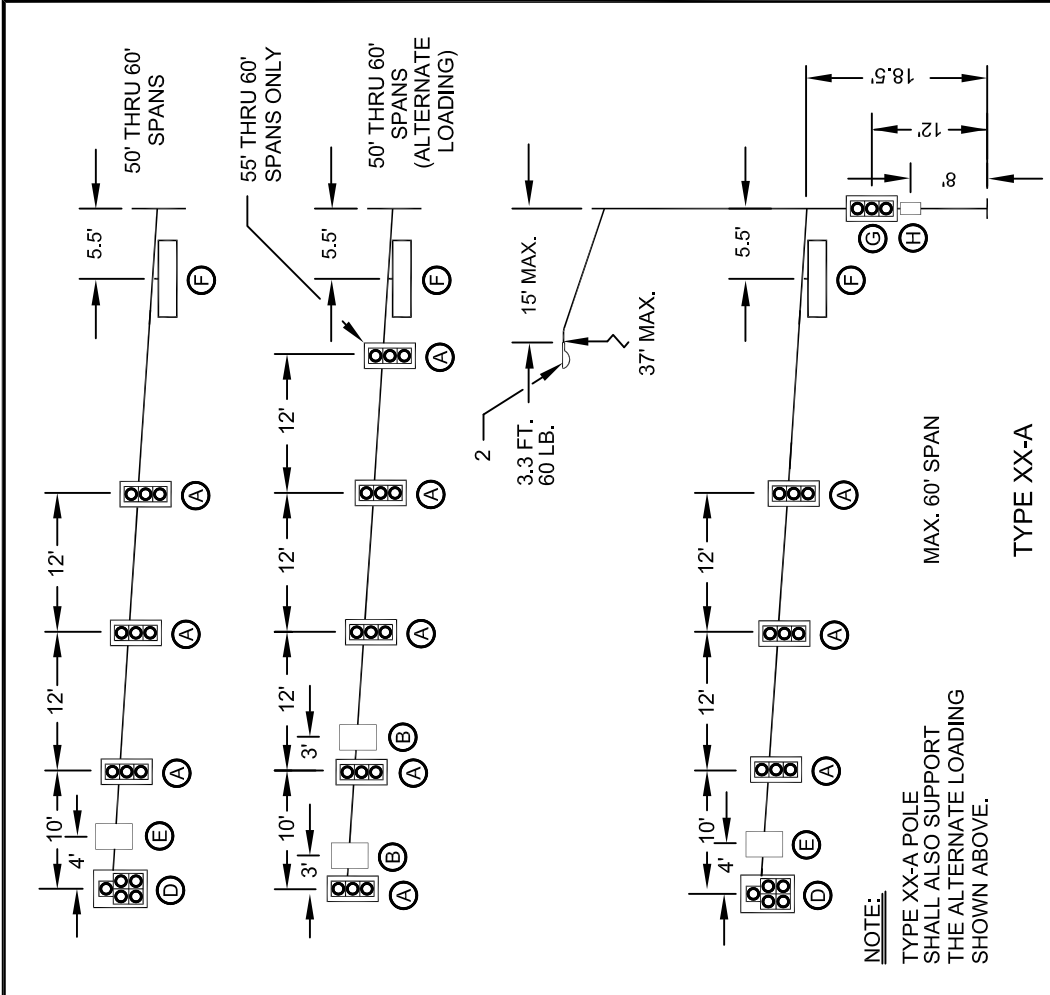
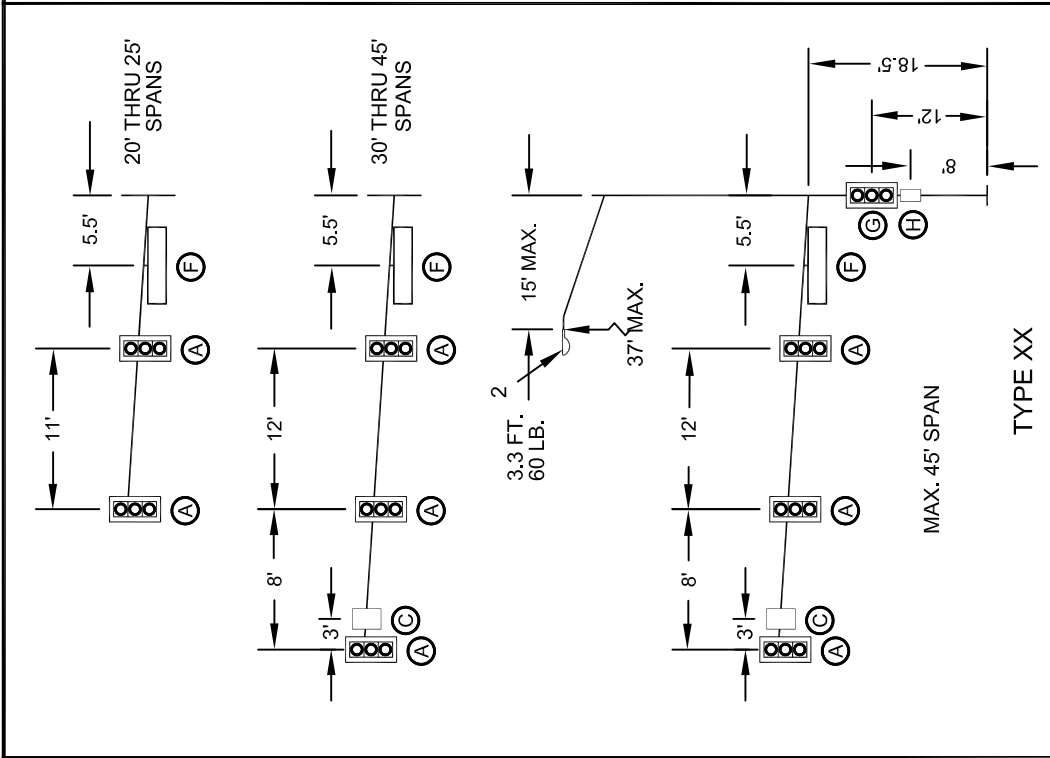

DESIGN CRITERIA:

1985 AASHTO STANDARD SPECIFICATIONS FOR STRUCTURAL SUPPORTS FOR HIGHWAY SIGNS, LUMINAIRES AND TRAFFIC SIGNALS.

MAXIMUM DESIGN MINIMUM YIELD STRENGTH FOR TUBULAR MEMBERS SHALL BE LIMITED TO 48,000 PSI FOR COLD WORKED MATERIALS AND 50,000 PSI FOR NON-COLD WORKED MATERIALS.

WIND VELOCITY:
80 MPH ISOTACH.

DEVICE	DESCRIPTION	PROJ. AREA (FT ²)	WEIGHT (LBS)
(A) SIGNAL	12" - 3 SEC. W/ BACKPLATES (M-2)	9.80	40
(B) SIGN	R3-5 24" X 30"	5.00	15
(C) SIGN	R3-4 24" X 24"	4.00	10
(D) SIGNAL	12" - 5 SEC. W/ BACKPLATES	13.68	80
(E) SIGN	R10-5d(8) 36" X 45"	11.25	30
(F) SIGN	STREET NAME-FREE SWINGING-1.68' X 8'	13.44	100
(G) SIGNAL	DUAL-12" - 3 SEC. W/ BACKPLATES	17.34	80
(H) SIGNAL	DUAL-PEDESTRIAN	8.00	60

LOADING INFORMATION

SIGNAL STANDARD

HANDHOLE AND COVER (SHALL FACE AWAY FROM ONCOMING TRAFFIC)

HEX HEAD NON-CORROSIVE CAP SCREW WITH FLAT WASHER WITH A SINGLE-STRAND BARE NO. 4 AWG COPPER GROUNDING CONDUCTOR

NOTE:

EACH CONDUCTOR SHALL HAVE A MINIMUM OF 18 INCHES OF SLACK

SPLIT-BOLT CONNECTOR

3"

#8 GREEN THWN BONDING CONDUCTOR CONNECTED TO POLE GROUND WITH SPLIT BOLT CONNECTOR

BRONZE GROUNDING CONNECTOR (UL LISTED FOR UNDERGROUND USE) FOR NO.4 WIRE

CONTINUOUS BARE COPPER GROUNDING WIRE SHALL BE LOOPED AROUND ANCHOR BOLTS ONE TIME AND CONNECTED TO EACH ANCHOR BOLT BEFORE CONTINUING DOWN TO THE GROUNDING PLATE. (GROUNDING CONFIGURATION DIFFERS FOR TYPE "L" FOUNDATION. SEE STANDARD DRAWING NO. 404.209)

SPECIFICATION REFERENCE

UNIFORM STANDARD DRAWINGS
CLARK COUNTY AREA

TRAFFIC SIGNAL POLE
GROUNDING

DATE 12-12-96 DWG. NO. 404.406 SHEET 6 OF 6

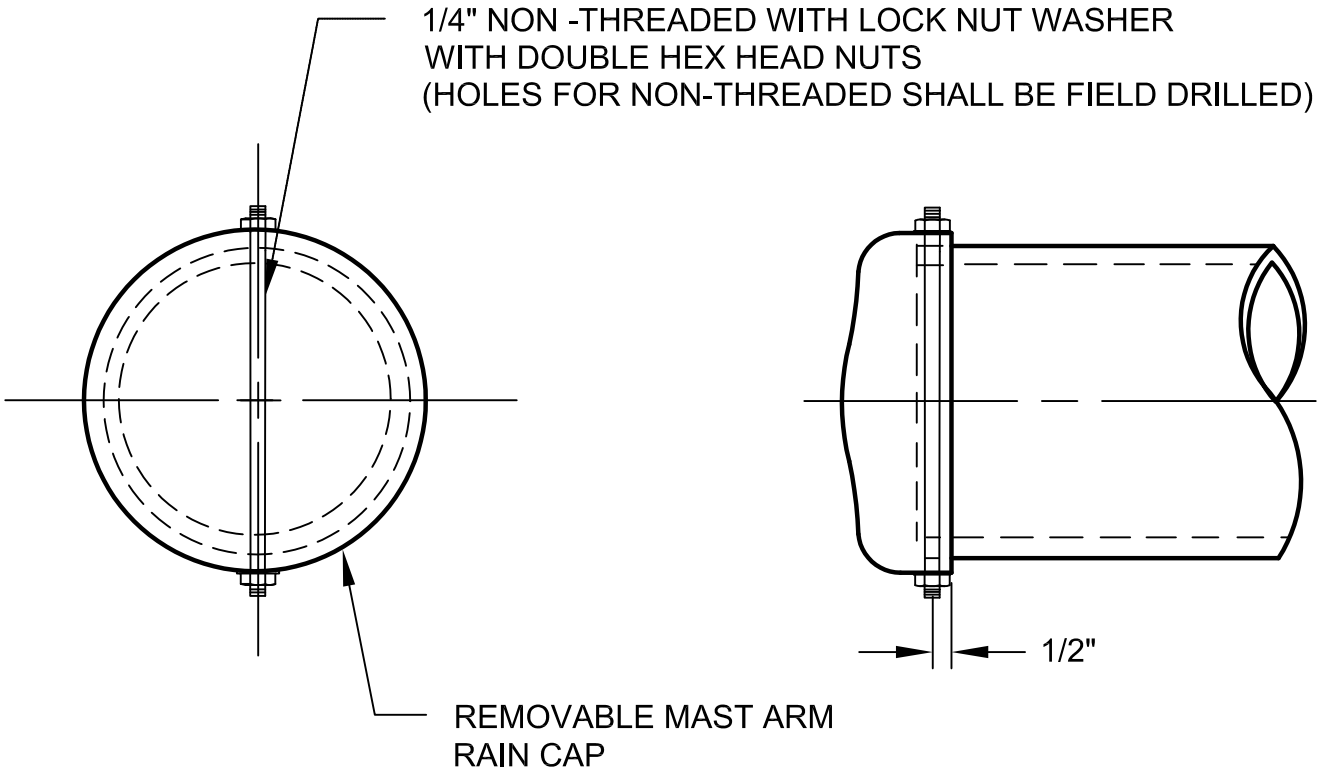

Effective 01/01/09 - 06/30/09

SPECIFICATION REFERENCE		UNIFORM STANDARD DRAWINGS CLARK COUNTY AREA			
623	TRAFFIC SIGNALS & STREET LIGHTING	REMOVABLE MAST ARM END CAP DETAIL			
		DATE 05-19-05	DWG. NO. 404.406A	SHEET	1 OF 1

LUMINAIRE MOUNTING HEIGHT MEASURED TO CENTER OF END OF MAST ARM

LUMINAIRE ARM DATA				
ARM SPAN "L" (FT)	FIXED END DIA. (IN)	FREE END DIA. (IN)	GAUGE	LUMINAIRE MOUNTING HEIGHT
6	3.42	2.38	11	32'-0"
8	3.75	2.38	11	33'-3"
10	4.16	2.38	11	35'-0"
12	4.52	2.38	11	36'-6"
15	4.95	2.38	11	37'-0"

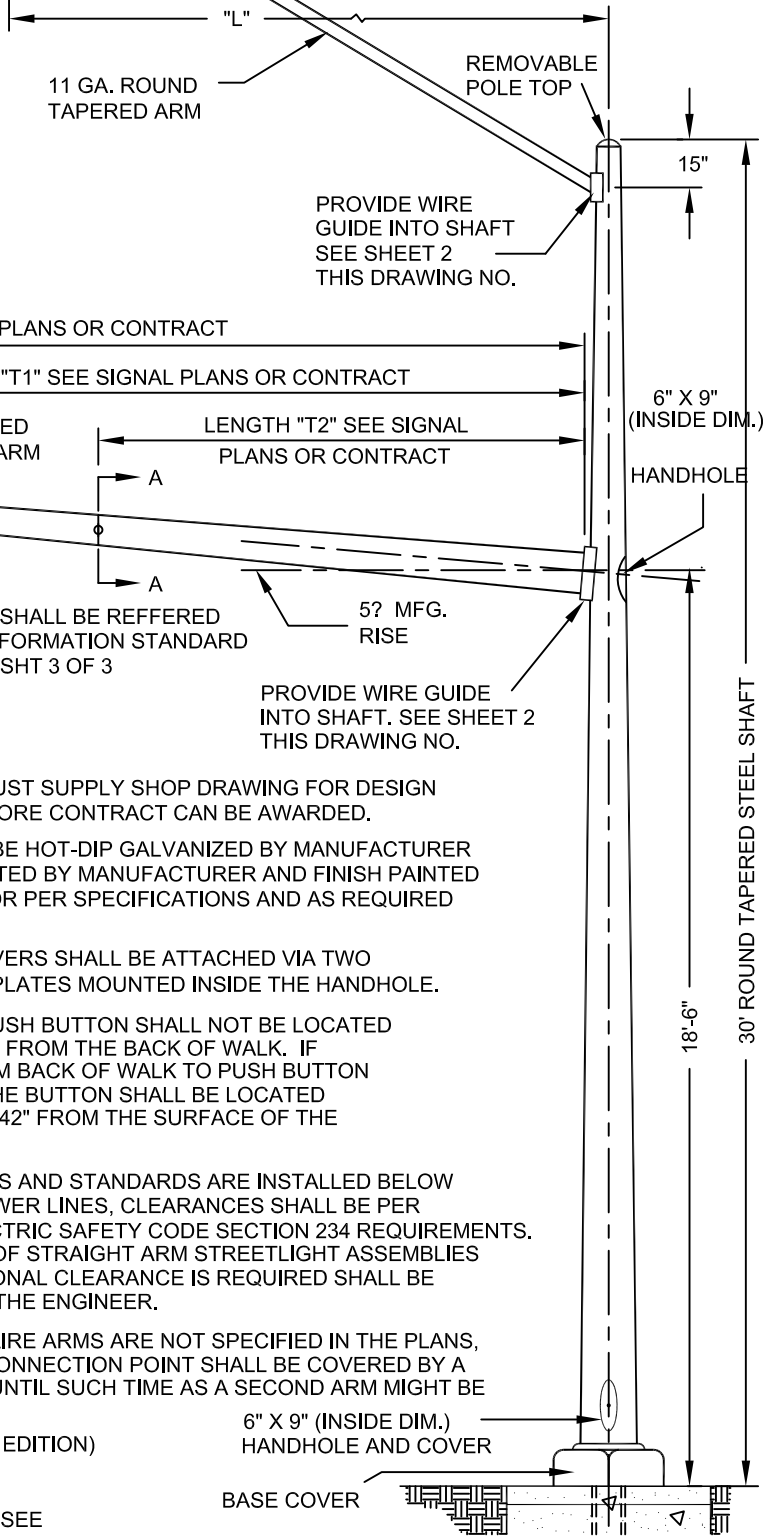

REMOVABLE ARM END CAP

LENGTH "L" SEE SIGNAL PLANS OR CONTRACT

LENGTH "T1" SEE SIGNAL PLANS OR CONTRACT

LENGTH "T2" SEE SIGNAL PLANS OR CONTRACT

TENON LOCATIONS SHALL BE REFERRED TO THE LOADING INFORMATION STANDARD DRAWING 404.406B SHT 3 OF 3

NOTES:

1. LOW BIDDER MUST SUPPLY SHOP DRAWING FOR DESIGN APPROVAL BEFORE CONTRACT CAN BE AWARDED.
2. ALL POLES TO BE HOT-DIP GALVANIZED BY MANUFACTURER OR PRIME PAINTED BY MANUFACTURER AND FINISH PAINTED BY CONTRACTOR PER SPECIFICATIONS AND AS REQUIRED BY THE ENTITY.
3. HANDHOLE COVERS SHALL BE ATTACHED VIA TWO SCREWS INTO PLATES MOUNTED INSIDE THE HANDHOLE.
4. PEDESTRIAN PUSH BUTTON SHALL NOT BE LOCATED MORE THAN 24" FROM THE BACK OF WALK. IF DISTANCE FROM BACK OF WALK TO PUSH BUTTON IS 20" TO 24", THE BUTTON SHALL BE LOCATED A MAXIMUM OF 42" FROM THE SURFACE OF THE WALK.
5. WHERE SIGNALS AND STANDARDS ARE INSTALLED BELOW OVERHEAD POWER LINES, CLEARANCES SHALL BE PER NATIONAL ELECTRIC SAFETY CODE SECTION 234 REQUIREMENTS. INSTALLATION OF STRAIGHT ARM STREETLIGHT ASSEMBLIES WHERE ADDITIONAL CLEARANCE IS REQUIRED SHALL BE APPROVED BY THE ENGINEER.
6. IF DUAL LUMINAIRE ARMS ARE NOT SPECIFIED IN THE PLANS, THE SECOND CONNECTION POINT SHALL BE COVERED BY A COVER PLATE UNTIL SUCH TIME AS A SECOND ARM MIGHT BE ADDED.

2" SCH. 40 PIPE TENON WITH 7/16" THRU HOLE FOR ELEVATOR PLUMBIZER

DETAIL A-A

POLES DESIGNED PER SPECIFICATION OF A.A.S.H.T.O. (1994 EDITION) 80 MPH WINDS. (SEE DRAWING NO. 404.406B SHEET 3 OF 3 FOR LOADING INFORMATION)

FOR "M" TYPE FOUNDATION SEE DRAWING NO. 404.210

SPECIFICATION REFERENCE

UNIFORM STANDARD DRAWINGS
CLARK COUNTY AREA

TYPE XX - B - 30'-0"
SIGNAL & LUMINAIRE POLE
(65' THRU 85' MAST ARMS)

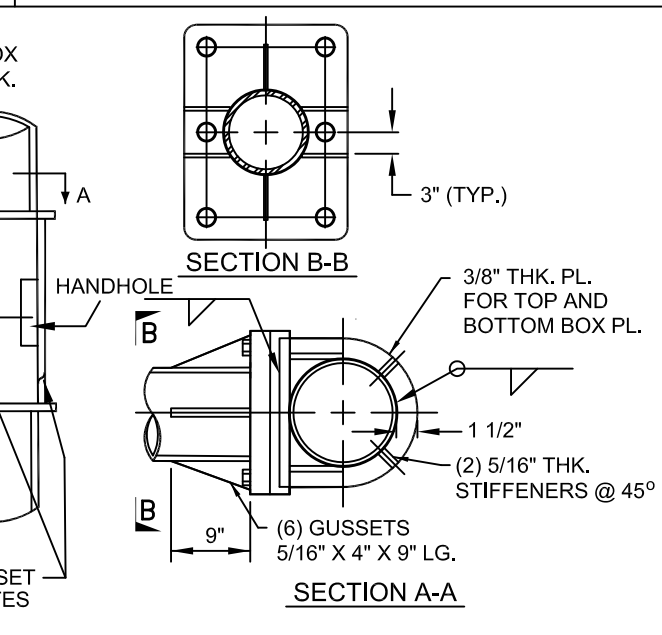
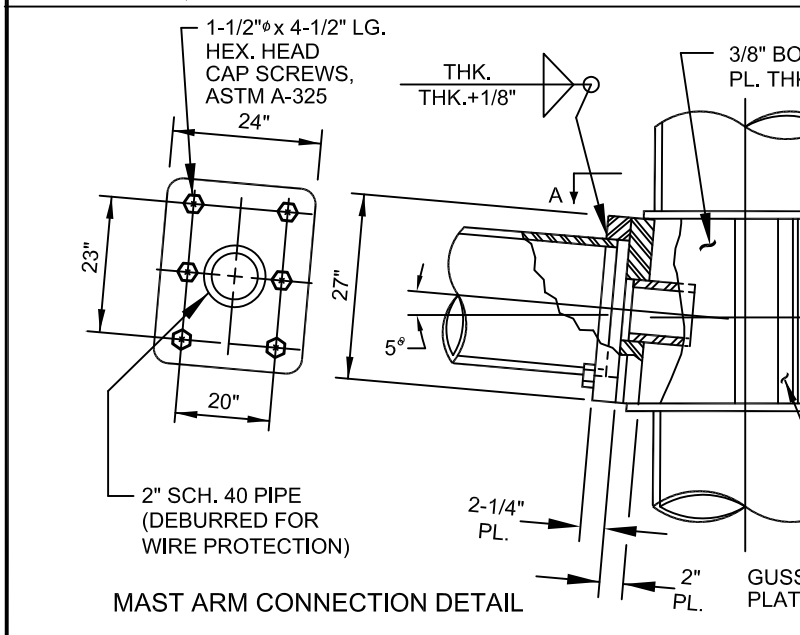
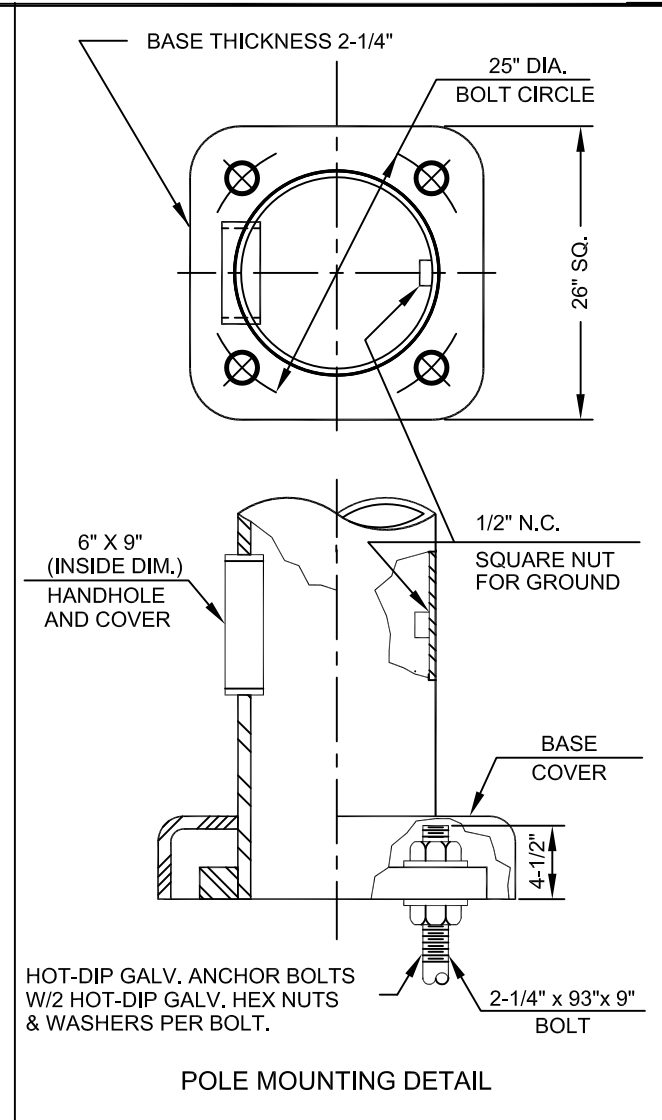
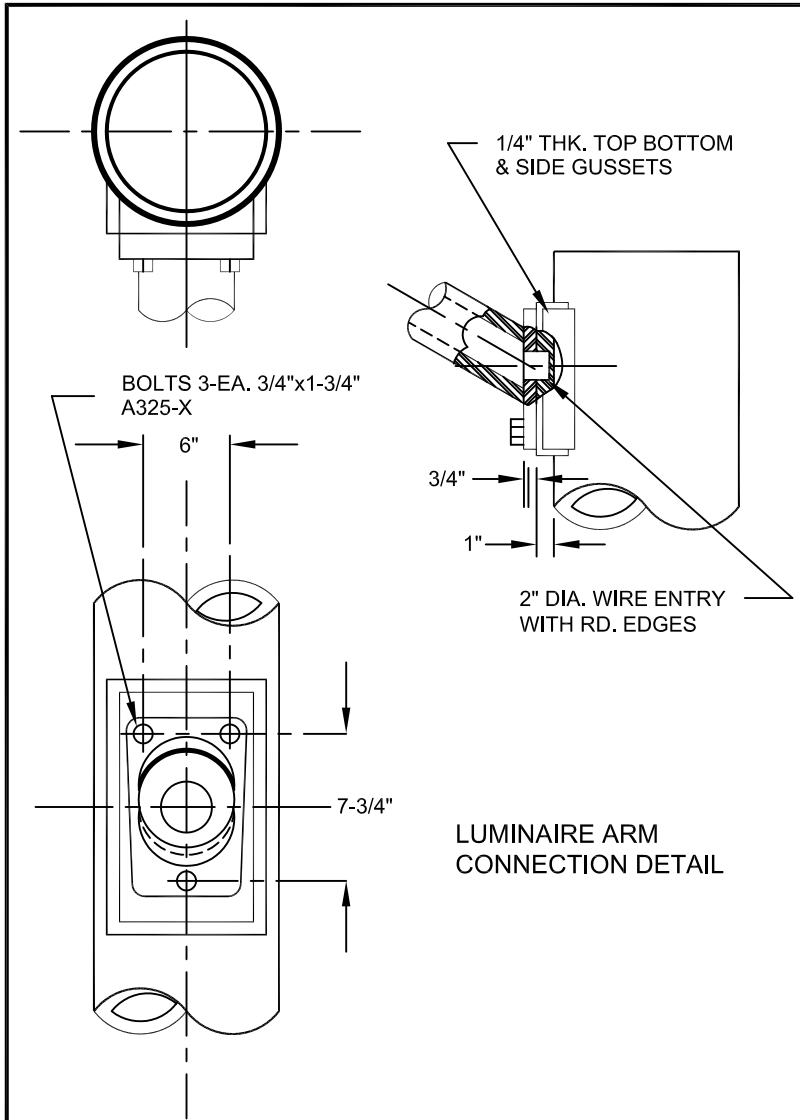

SPECIFICATION REFERENCE	

UNIFORM STANDARD DRAWINGS CLARK COUNTY AREA				
TYPE XX - B - 30'-0" (65' THRU 85' MAST ARMS) SIGNAL & LUMINAIRE POLE DETAILS				
DATE 11/10/05	DWG. NO.	404.406B	SHEET	2 OF 3

Effective 01/01/09 - 06/30/09

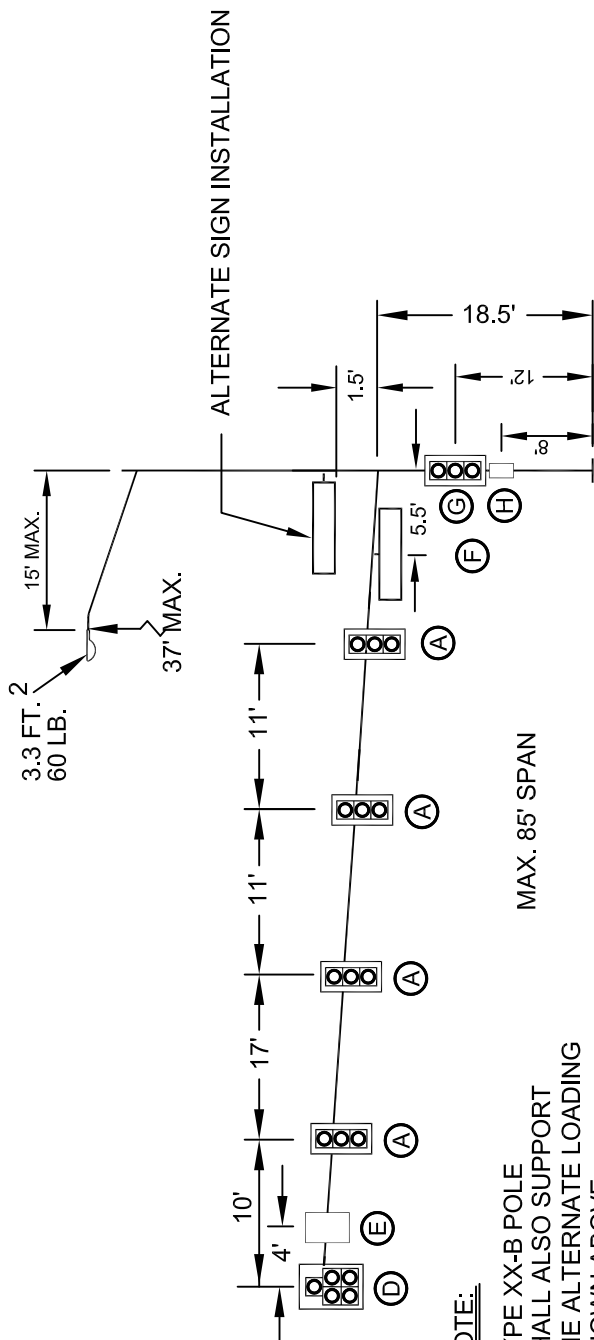
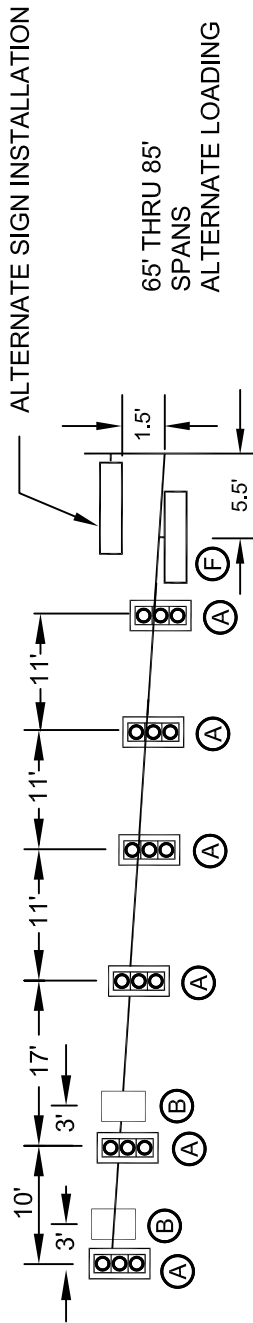

NOTE:
 TYPE XX-B POLE SHALL ALSO SUPPORT THE ALTERNATE LOADING SHOWN ABOVE.

DESIGN CRITERIA:

AASHTO STANDARD SPECIFICATIONS (1994 EDITION) FOR STRUCTURAL SUPPORTS FOR HIGHWAY SIGNS, LUMINAIRES AND TRAFFIC SIGNALS.
 DESIGN MINIMUM YIELD STRENGTH FOR TUBULAR MEMBERS SHALL BE LIMITED TO 48,000 PSI FOR COLD WORKED MATERIALS AND 50,000 PSI FOR NON-COLD WORKED MATERIALS.
 WIND VELOCITY:
 80 MPH ISOTACH.

DEVICE	DESCRIPTION	PROJ. AREA (FT ²)	WEIGHT (LBS)
(A) SIGNAL	12" - 3 SEC. W/ BACKPLATES (M-2)	9.80	40
(B) SIGN	R3-5 24" X 30"	5.00	15
(C) SIGN	R3-4 24" X 24"	4.00	10
(D) SIGNAL	12" - 5 SEC. W/ BACKPLATES	13.68	80
(E) SIGN	R10-5d(8) 24" X 36"	6.00	15
(F) SIGN	STREET NAME-FREE SWINGING-1.68' X 8'	13.44	100
(G) SIGNAL	DUAL-12" - 3 SEC. W/ BACKPLATES	17.34	80
(H) SIGNAL	DUAL-PEDESTRIAN	8.00	60

SPECIFICATION REFERENCE

UNIFORM STANDARD DRAWINGS
 CLARK COUNTY AREA

LOADING INFORMATION

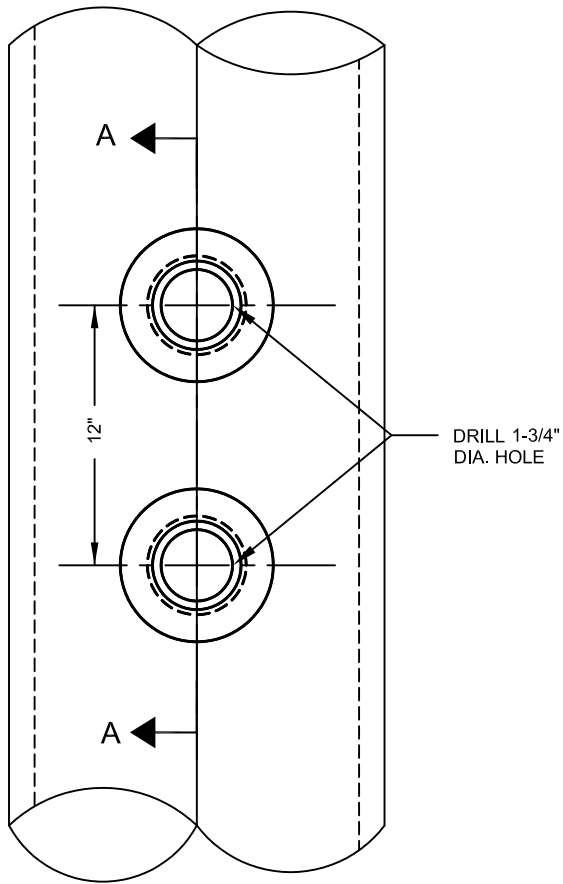

DRILLING DETAIL

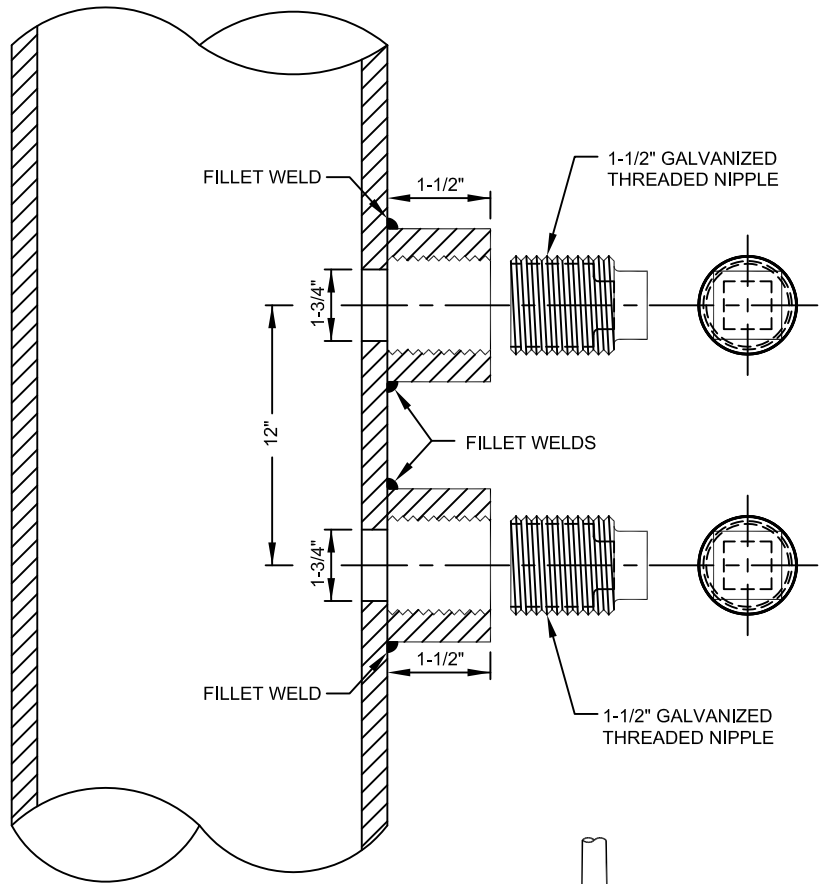

NIPPLE DETAIL SECTION A-A

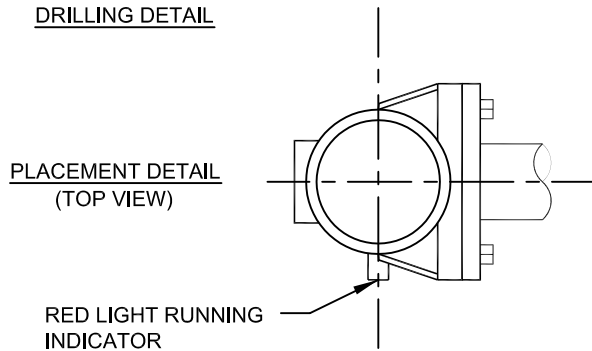

PLACEMENT DETAIL (TOP VIEW)

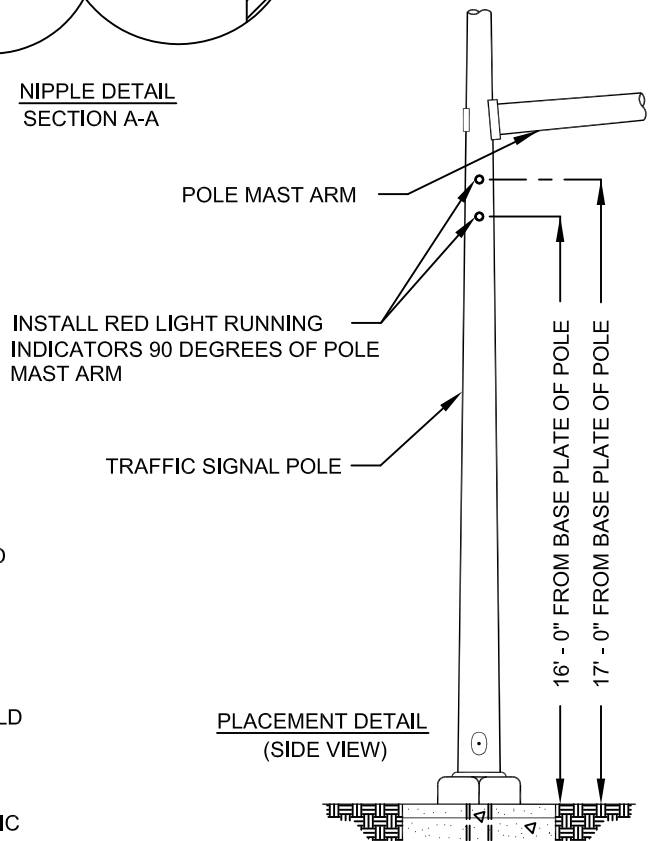

PLACEMENT DETAIL (SIDE VIEW)

NOTES:

1. CONTRACTOR TO INSTALL RED LIGHT RUNNING INDICATORS, McCAIN MODELS M61385 (RED) & M61448 (BLUE), OR APPROVED EQUAL AS INDICATED BY THE TRAFFIC ENGINEER.
2. RED (THRU) INDICATOR SHALL BE MOUNTED 16' ABOVE POLE BASE PLATE AND BLUE (LEFT) INDICATOR SHALL BE MOUNTED 17' ABOVE POLE BASE PLATE AND SHALL FACE AWAY FROM ONCOMING TRAFFIC.
3. RED LIGHT RUNNING INDICATOR L.E.D. HOUSING SHALL BE FIELD ADJUSTED. PLEASE CONTACT THE TRAFFIC ENGINEER FOR COORDINATION.
4. CONTRACTOR SHALL WIRE INDICATORS DIRECTLY TO BUSS IN "J" BOX PER CALL OUT PHASING IN POLE SCHEDULE ON TRAFFIC SIGNAL PLANS.

SPECIFICATION REFERENCE

UNIFORM STANDARD DRAWINGS
CLARK COUNTY AREA

CLARK COUNTY ONLY
RED LIGHT RUNNING INDICATOR
INSTALLATION DETAILS

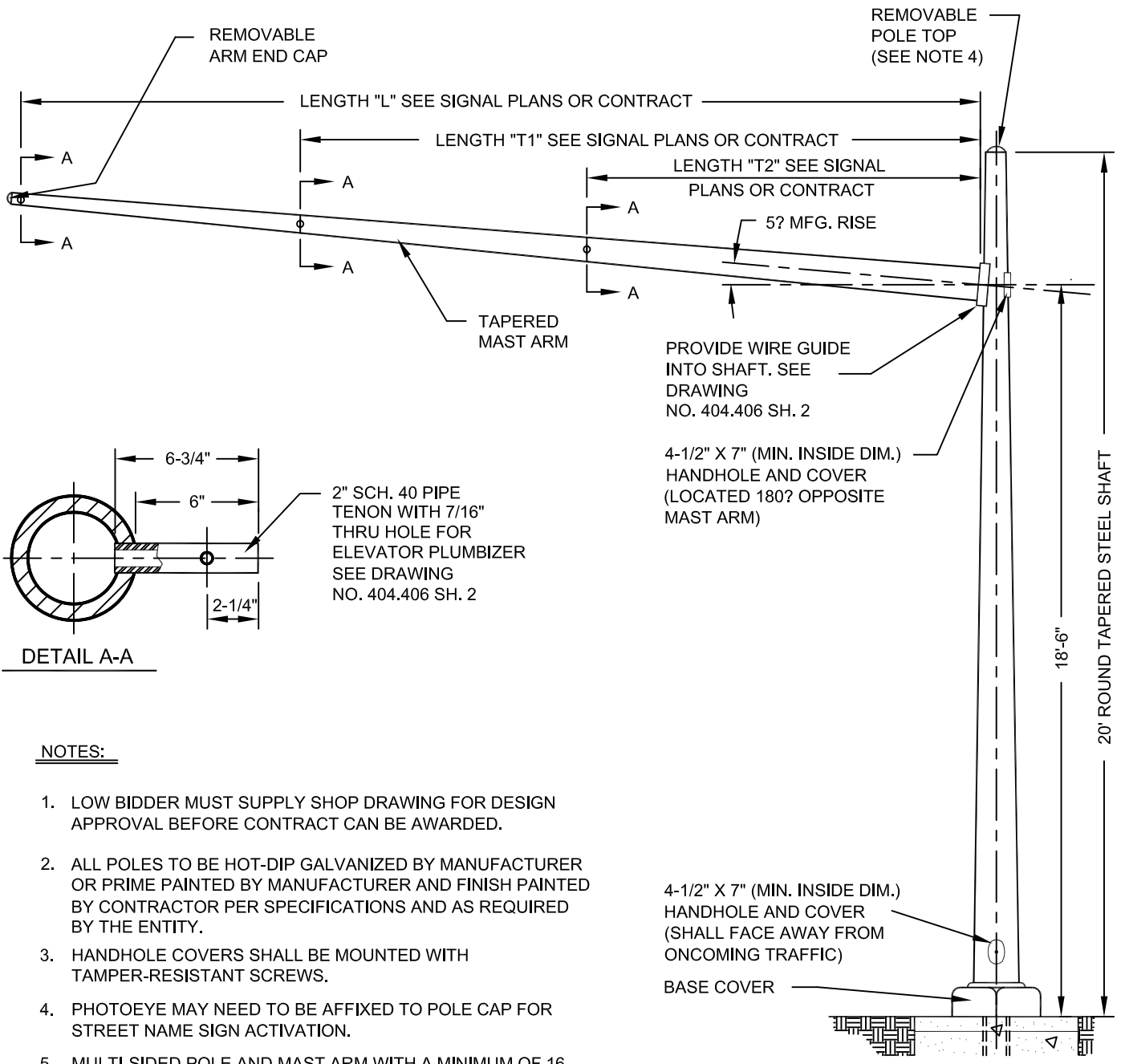

NOTES:

1. LOW BIDDER MUST SUPPLY SHOP DRAWING FOR DESIGN APPROVAL BEFORE CONTRACT CAN BE AWARDED.
2. ALL POLES TO BE HOT-DIP GALVANIZED BY MANUFACTURER OR PRIME PAINTED BY MANUFACTURER AND FINISH PAINTED BY CONTRACTOR PER SPECIFICATIONS AND AS REQUIRED BY THE ENTITY.
3. HANDHOLE COVERS SHALL BE MOUNTED WITH TAMPER-RESISTANT SCREWS.
4. PHOTOEYE MAY NEED TO BE AFFIXED TO POLE CAP FOR STREET NAME SIGN ACTIVATION.
5. MULTI-SIDED POLE AND MAST ARM WITH A MINIMUM OF 16 SIDES MAY BE USED IF DIRECTED BY THE ENTITY ENGINEER.

POLES DESIGNED PER SPECIFICATION OF A.A.S.H.T.O., 80 MPH WINDS.
(SEE DRAWING NO. 404.406 SHEET 5 FOR LOADING INFORMATION)

FOR OTHER DETAILS SEE DRAWING NO. 404.406 SHTS. 2 & 6.
FOR "H" TYPE FOUNDATION SEE DRAWING NO. 404.208.

SPECIFICATION REFERENCE		UNIFORM STANDARD DRAWINGS CLARK COUNTY AREA			
		TYPE XX 20'-0" SIGNAL POLE (45' OR LESS MAST ARMS)			
		DATE	9-14-06	DWG. NO.	404.407
				SHEET	1 OF 2

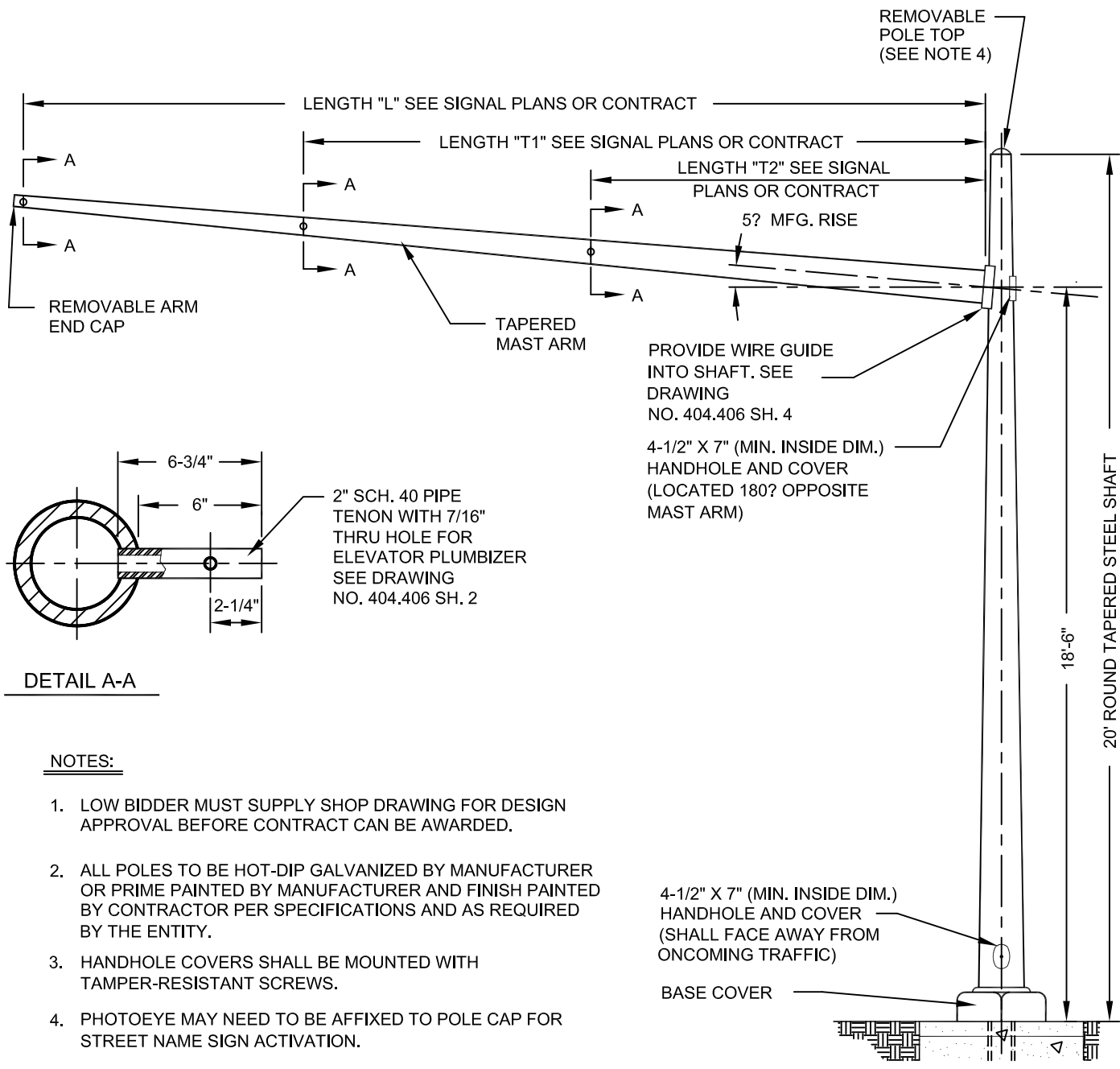

DETAIL A-A

NOTES:

1. LOW BIDDER MUST SUPPLY SHOP DRAWING FOR DESIGN APPROVAL BEFORE CONTRACT CAN BE AWARDED.
2. ALL POLES TO BE HOT-DIP GALVANIZED BY MANUFACTURER OR PRIME PAINTED BY MANUFACTURER AND FINISH PAINTED BY CONTRACTOR PER SPECIFICATIONS AND AS REQUIRED BY THE ENTITY.
3. HANDHOLE COVERS SHALL BE MOUNTED WITH TAMPER-RESISTANT SCREWS.
4. PHOTOEYE MAY NEED TO BE AFFIXED TO POLE CAP FOR STREET NAME SIGN ACTIVATION.
5. MULTI-SIDED POLE MAST ARM WITH A MINIMUM OF 16 SIDES MAY BE USED IF DIRECTED BY THE ENTITY ENGINEER.

POLES DESIGNED PER SPECIFICATION OF A.A.S.H.T.O., 80 MPH WINDS.
(SEE DRAWING NO. 404.406 SHEET 5 FOR LOADING INFORMATION)

FOR OTHER DETAILS SEE DRAWING NO. 404.406 SHTS. 4 & 6.

FOR "L" TYPE FOUNDATION SEE DRAWING NO. 404.209.

SPECIFICATION REFERENCE	UNIFORM STANDARD DRAWINGS CLARK COUNTY AREA			
	TYPE XX-A-20'-0" (50' THRU 60' MAST ARMS) SIGNAL POLE			
	DATE 9-14-06	DWG. NO. 404.407	SHEET	2 OF 2

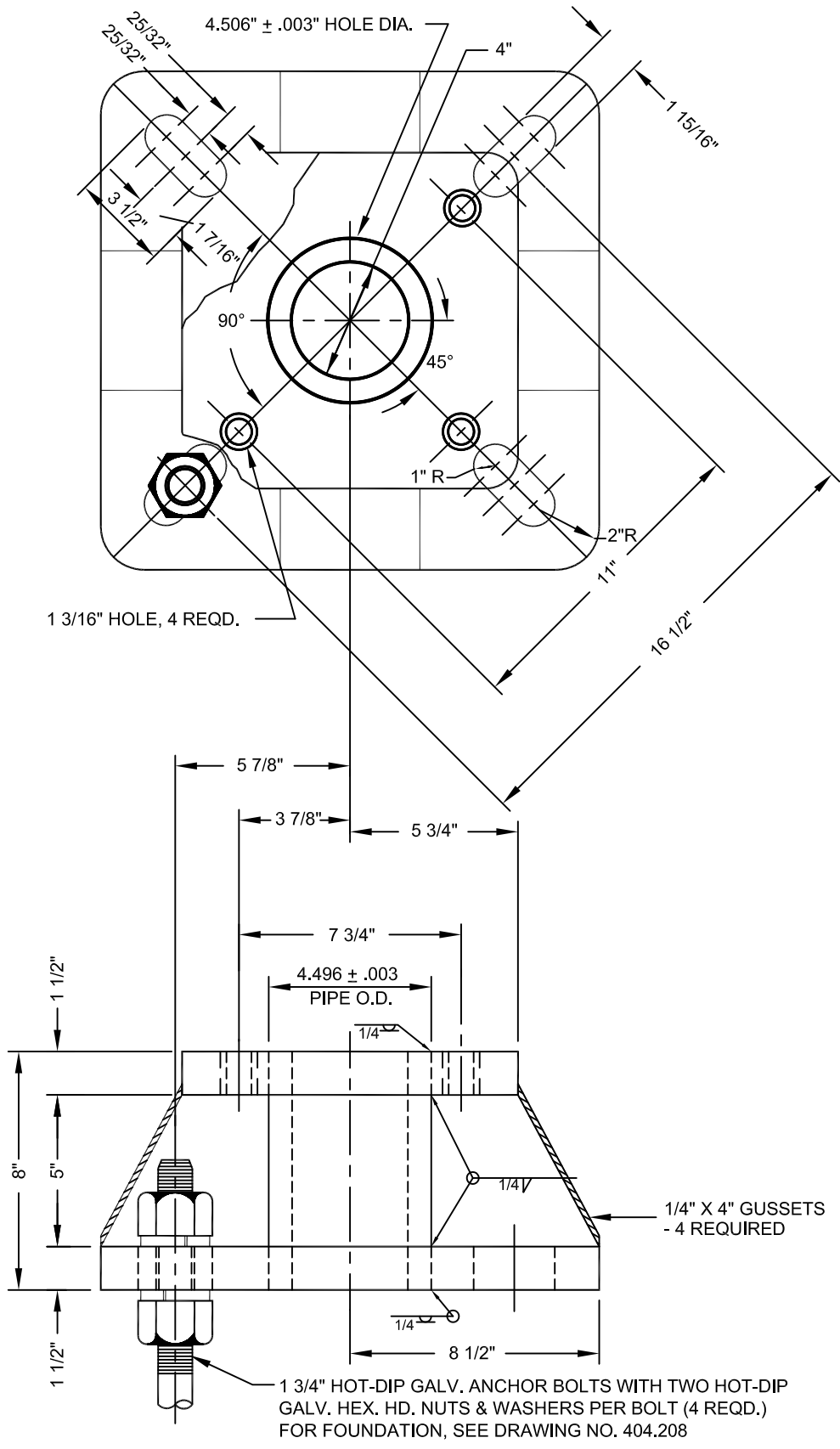

1 3/16" HOLE, 4 REQD.

1/4" X 4" GUSSETS
- 4 REQUIRED

1 3/4" HOT-DIP GALV. ANCHOR BOLTS WITH TWO HOT-DIP GALV. HEX. HD. NUTS & WASHERS PER BOLT (4 REQD.) FOR FOUNDATION, SEE DRAWING NO. 404.208

SPECIFICATION REFERENCE

UNIFORM STANDARD DRAWINGS
CLARK COUNTY AREA

BASE ADAPTOR PLATE
FOR TYPE "H" FOUNDATION

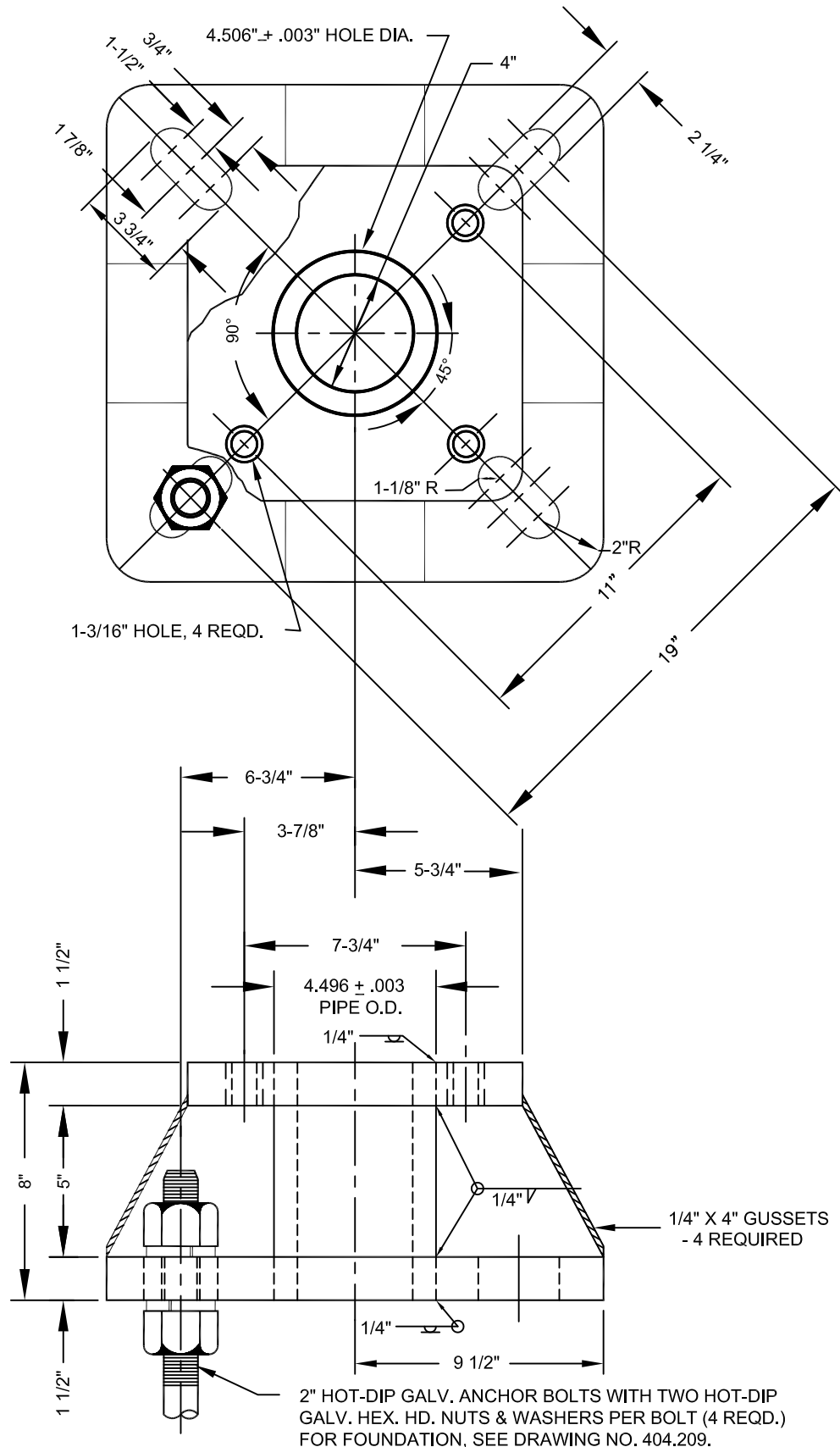

SPECIFICATION REFERENCE

UNIFORM STANDARD DRAWINGS
CLARK COUNTY AREA

BASE ADAPTOR PLATE
FOR TYPE "L" FOUNDATION

DATE 12-12-96

DWG. NO.

404.409

SHEET

2 OF 2

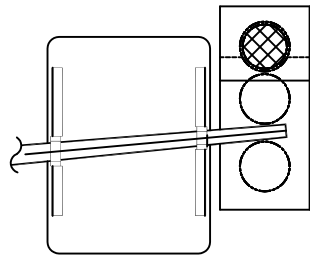

BACK VIEW OF SIGN

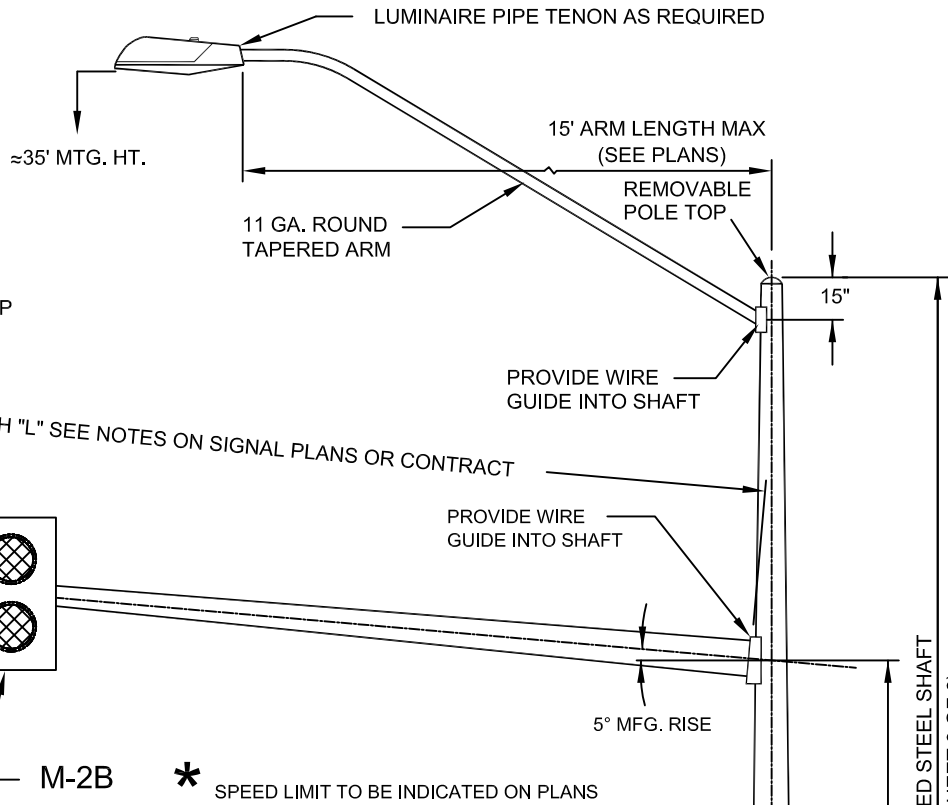

FRONT VIEW

NOTES:

1. ALL POLES TO BE HOT-DIP GALVANIZED BY MANUFACTURER OR PRIME PAINTED BY MANUFACTURER AND FINISH PAINTED BY CONTRACTOR PER SPECIFICATIONS AND AS REQUIRED BY THE ENTITY.
2. FOR MAST ARM TENON MOUNTING AND SPACING AND ADDITIONAL INFORMATION REFER TO STANDARD DRAWING NO. 404.412
3. MULTI SIDED POLE AND MAST ARM WITH A MINIMUM OF 16 SIDES MAY BE USED IF DIRECTED BY THE ENTITY ENGINEER.

FOR OTHER DETAILS SEE DRAWING NUMBER 404.406 SHT 2 & 6

FOR "H" TYPE FOUNDATION SEE DRAWING NO. 404.208

4" X 7" (INSIDE DIM.)
HANDHOLE AND COVER
(SHALL FACE AWAY FROM
ONCOMING TRAFFIC)
BASE COVER

17' MIN.

18'-6"

7' MIN.

30' ROUND TYPE XX-A TAPERED STEEL SHAFT
SAME AS DWG. 404.406 (SHEET 3 OF 6)

IN THE CITY OF NORTH LAS VEGAS, USE ONLY XX-A POLE DWG. 406.406 SHT 3 & 6
FOR "L" FOUNDATION SEE DWG. 404.209

SPECIFICATION REFERENCE

UNIFORM STANDARD DRAWINGS
CLARK COUNTY AREA

30' POLE WITH SCHOOL
FLASHING SIGN

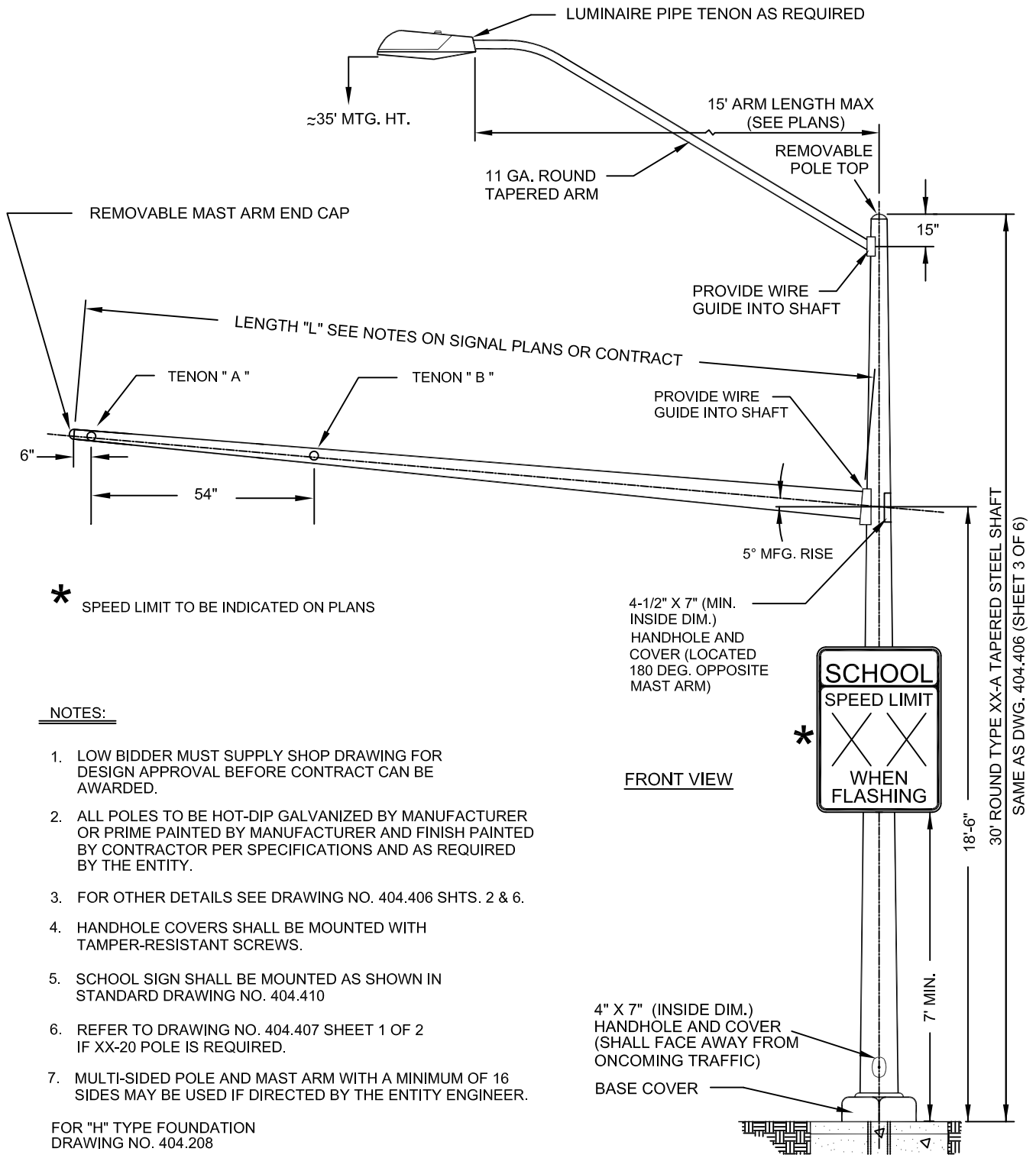

* SPEED LIMIT TO BE INDICATED ON PLANS

NOTES:

1. LOW BIDDER MUST SUPPLY SHOP DRAWING FOR DESIGN APPROVAL BEFORE CONTRACT CAN BE AWARDED.
2. ALL POLES TO BE HOT-DIP GALVANIZED BY MANUFACTURER OR PRIME PAINTED BY MANUFACTURER AND FINISH PAINTED BY CONTRACTOR PER SPECIFICATIONS AND AS REQUIRED BY THE ENTITY.
3. FOR OTHER DETAILS SEE DRAWING NO. 404.406 SHTS. 2 & 6.
4. HANDHOLE COVERS SHALL BE MOUNTED WITH TAMPER-RESISTANT SCREWS.
5. SCHOOL SIGN SHALL BE MOUNTED AS SHOWN IN STANDARD DRAWING NO. 404.410
6. REFER TO DRAWING NO. 404.407 SHEET 1 OF 2 IF XX-20 POLE IS REQUIRED.
7. MULTI-SIDED POLE AND MAST ARM WITH A MINIMUM OF 16 SIDES MAY BE USED IF DIRECTED BY THE ENTITY ENGINEER.

FOR "H" TYPE FOUNDATION
DRAWING NO. 404.208

IN THE CITY OF NORTH LAS VEGAS, USE ONLY XX-A POLE DWG. 406.406 SHT 3 & 6
FOR "L" FOUNDATION SEE DWG. 404.209

FRONT VIEW

4" X 7" (INSIDE DIM.)
HANDHOLE AND COVER
(SHALL FACE AWAY FROM
ONCOMING TRAFFIC)

BASE COVER

18'-6"
30' ROUND TYPE XX-A TAPERED STEEL SHAFT
SAME AS DWG. 404.406 (SHEET 3 OF 6)

Effective 01/01/09 - 06/30/09

SPECIFICATION REFERENCE		UNIFORM STANDARD DRAWINGS CLARK COUNTY AREA	
		SCHOOL SIGN POLE TYPE XX-A	
DATE	04-12-07	DWG. NO.	404.412

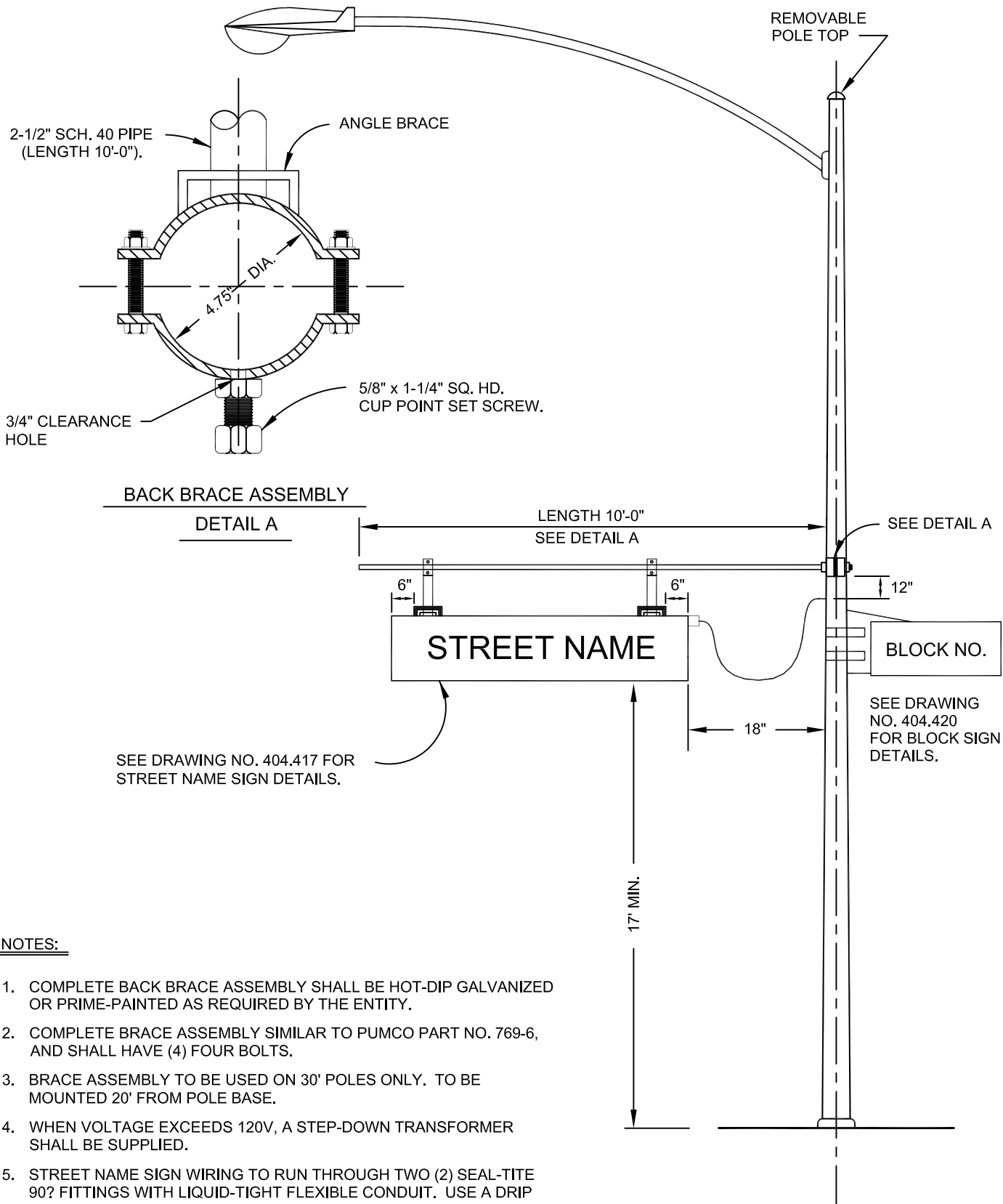

NOTES:

1. COMPLETE BACK BRACE ASSEMBLY SHALL BE HOT-DIP GALVANIZED OR PRIME-PAINTED AS REQUIRED BY THE ENTITY.
2. COMPLETE BRACE ASSEMBLY SIMILAR TO PUMCO PART NO. 769-6, AND SHALL HAVE (4) FOUR BOLTS.
3. BRACE ASSEMBLY TO BE USED ON 30' POLES ONLY. TO BE MOUNTED 20' FROM POLE BASE.
4. WHEN VOLTAGE EXCEEDS 120V, A STEP-DOWN TRANSFORMER SHALL BE SUPPLIED.
5. STREET NAME SIGN WIRING TO RUN THROUGH TWO (2) SEAL-TITE 90° FITTINGS WITH LIQUID-TIGHT FLEXIBLE CONDUIT. USE A DRIP LOOP SUFFICIENT ENOUGH TO ALLOW SIGN TO SWING FREELY.

SPECIFICATION REFERENCE

UNIFORM STANDARD DRAWINGS
CLARK COUNTY AREA

STREETLIGHTING POLE WITH
ILLUMINATED STREET NAME SIGN

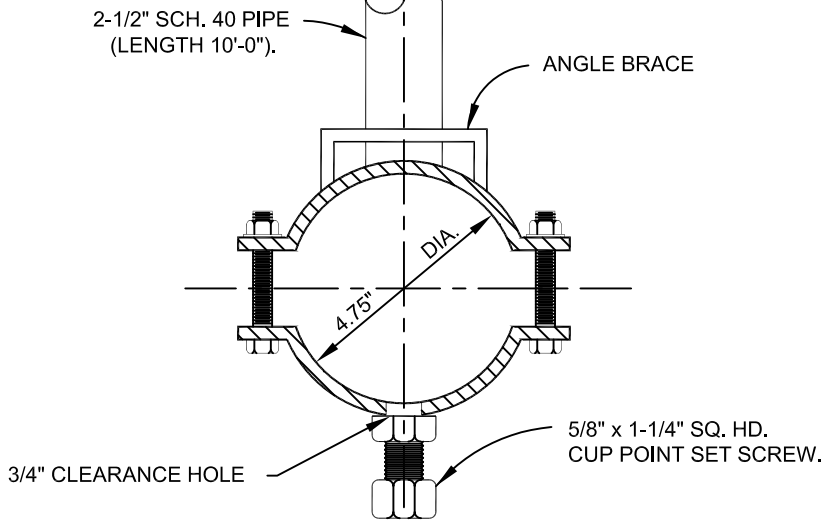
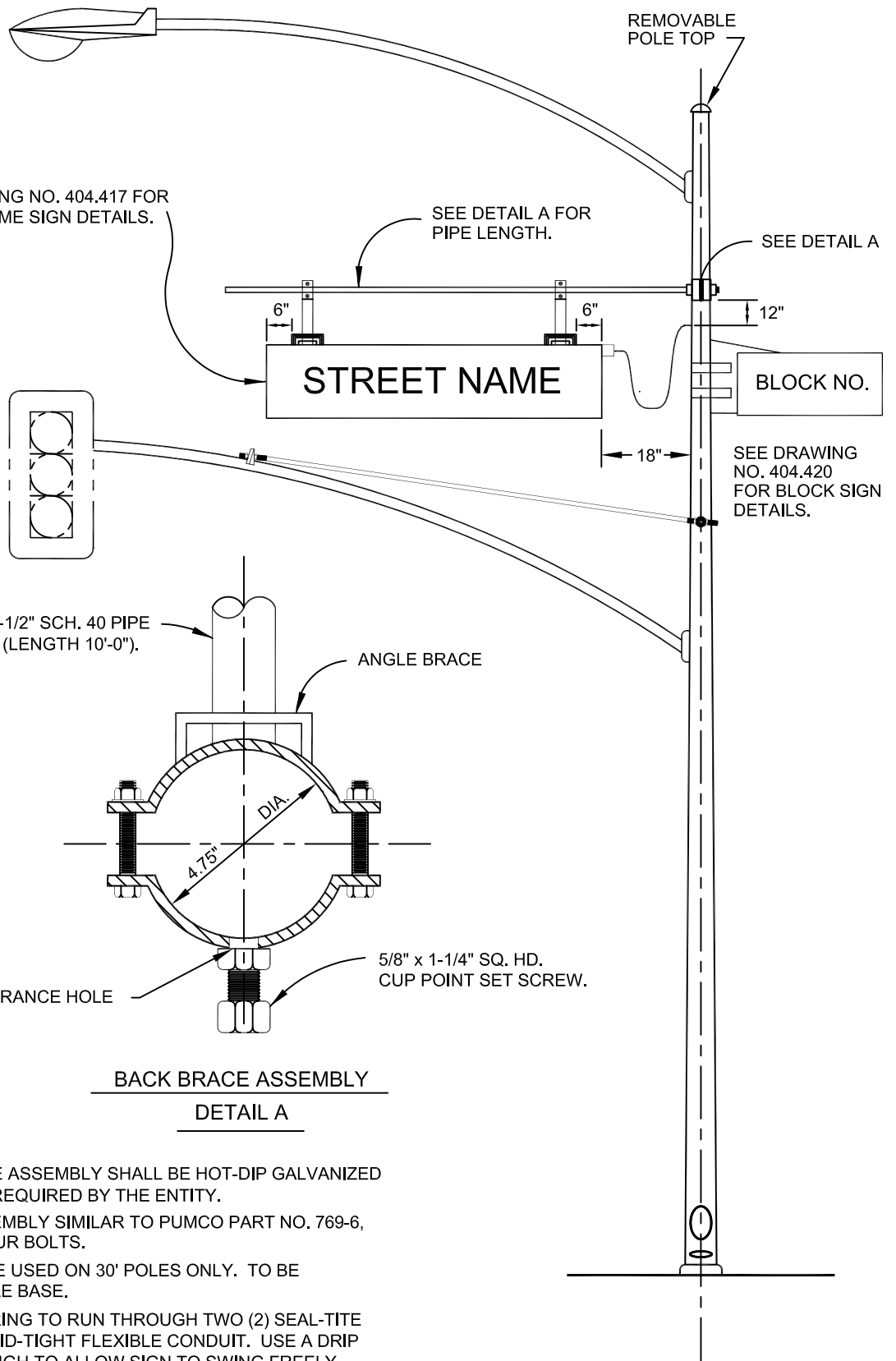

**BACK BRACE ASSEMBLY
DETAIL A**

NOTES:

1. COMPLETE BACK BRACE ASSEMBLY SHALL BE HOT-DIP GALVANIZED OR PRIME-PAINTED AS REQUIRED BY THE ENTITY.
2. COMPLETE BRACE ASSEMBLY SIMILAR TO PUMCO PART NO. 769-6, AND SHALL HAVE (4) FOUR BOLTS.
3. BRACE ASSEMBLY TO BE USED ON 30' POLES ONLY. TO BE MOUNTED 24' FROM POLE BASE.
4. STREET NAME SIGN WIRING TO RUN THROUGH TWO (2) SEAL-TITE 90° FITTINGS WITH LIQUID-TIGHT FLEXIBLE CONDUIT. USE A DRIP LOOP SUFFICIENT ENOUGH TO ALLOW SIGN TO SWING FREELY.

SPECIFICATION REFERENCE

UNIFORM STANDARD DRAWINGS
CLARK COUNTY AREA

TYPE III POLE WITH
ILLUMINATED STREET NAME SIGN

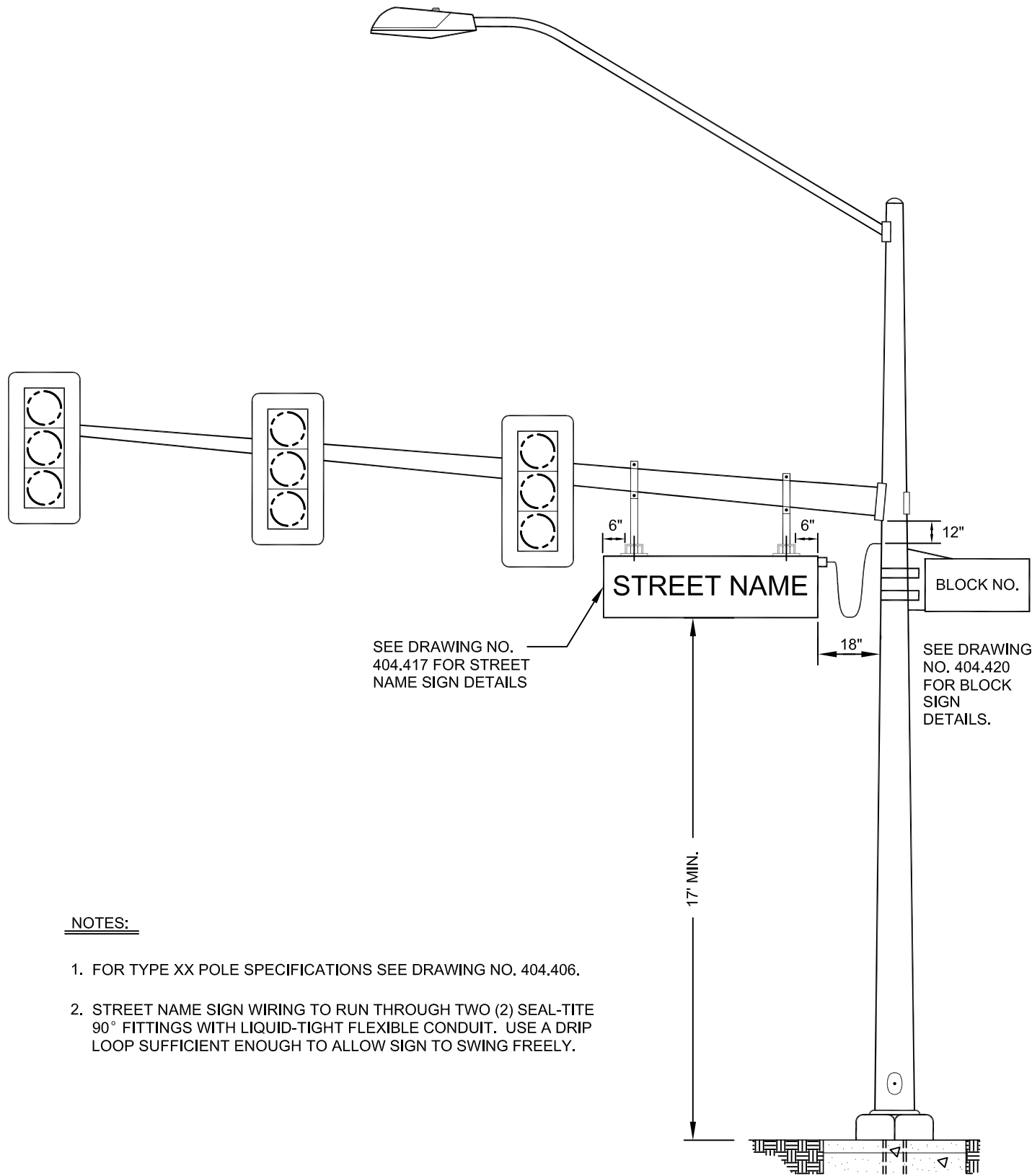

NOTES:

1. FOR TYPE XX POLE SPECIFICATIONS SEE DRAWING NO. 404.406.
2. STREET NAME SIGN WIRING TO RUN THROUGH TWO (2) SEAL-TITE 90° FITTINGS WITH LIQUID-TIGHT FLEXIBLE CONDUIT. USE A DRIP LOOP SUFFICIENT ENOUGH TO ALLOW SIGN TO SWING FREELY.

SPECIFICATION REFERENCE

UNIFORM STANDARD DRAWINGS
CLARK COUNTY AREA

TYPE XX POLE WITH
ILLUMINATED STREET NAME SIGN

DATE	4-9-98	DWG. NO.	404.416	SHEET	1 OF 1
------	--------	----------	---------	-------	--------

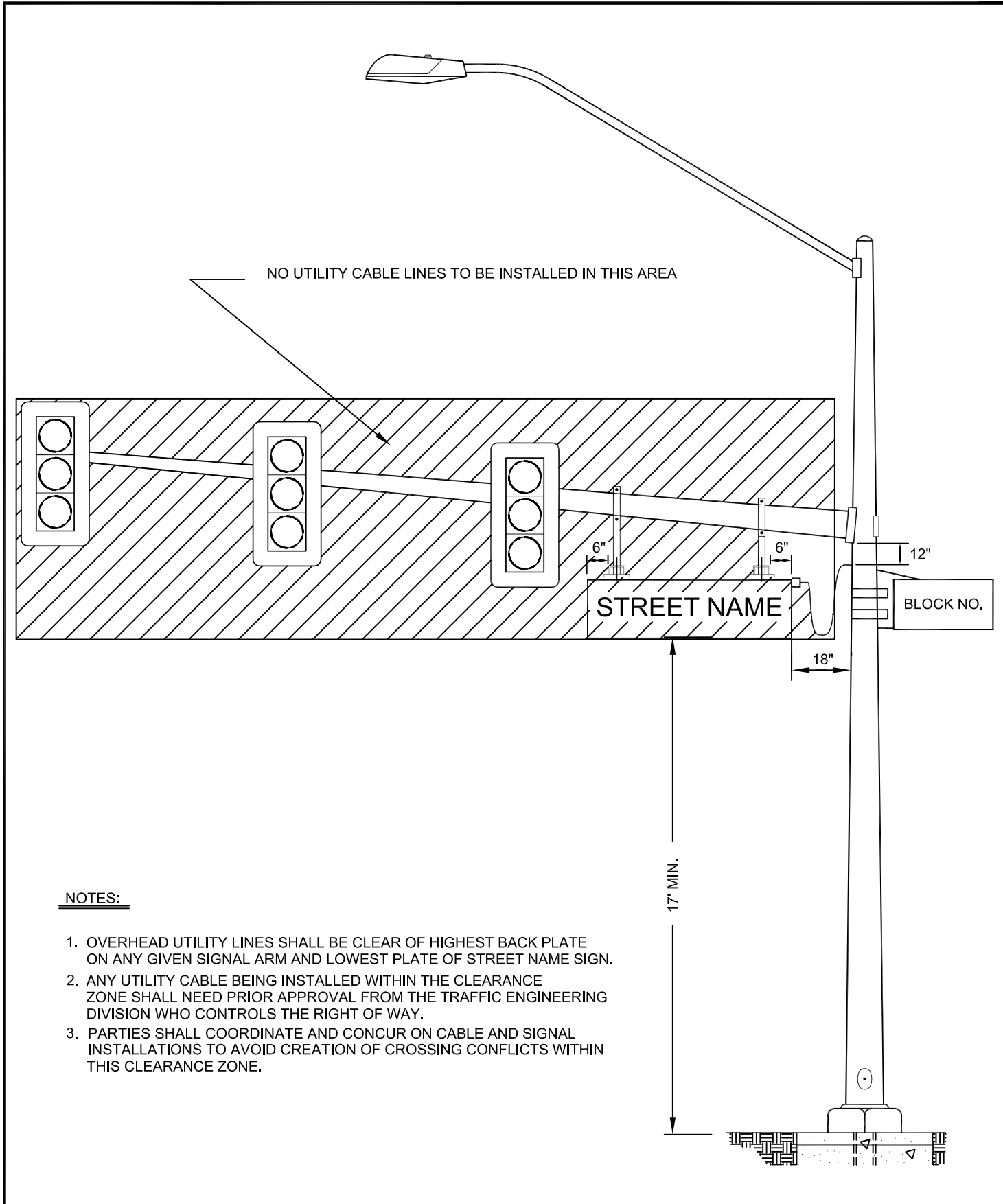

NOTES:

1. OVERHEAD UTILITY LINES SHALL BE CLEAR OF HIGHEST BACK PLATE ON ANY GIVEN SIGNAL ARM AND LOWEST PLATE OF STREET NAME SIGN.
2. ANY UTILITY CABLE BEING INSTALLED WITHIN THE CLEARANCE ZONE SHALL NEED PRIOR APPROVAL FROM THE TRAFFIC ENGINEERING DIVISION WHO CONTROLS THE RIGHT OF WAY.
3. PARTIES SHALL COORDINATE AND CONCUR ON CABLE AND SIGNAL INSTALLATIONS TO AVOID CREATION OF CROSSING CONFLICTS WITHIN THIS CLEARANCE ZONE.

Effective 01/01/09 - 06/30/09

SPECIFICATION REFERENCE	UNIFORM STANDARD DRAWINGS CLARK COUNTY AREA		
	UTILITY CABLE CLEARANCE OVER TRAFFIC SIGNALS NEW INSTALLATION ONLY		
	DATE 2-08-07	DWG. NO.	404.416A

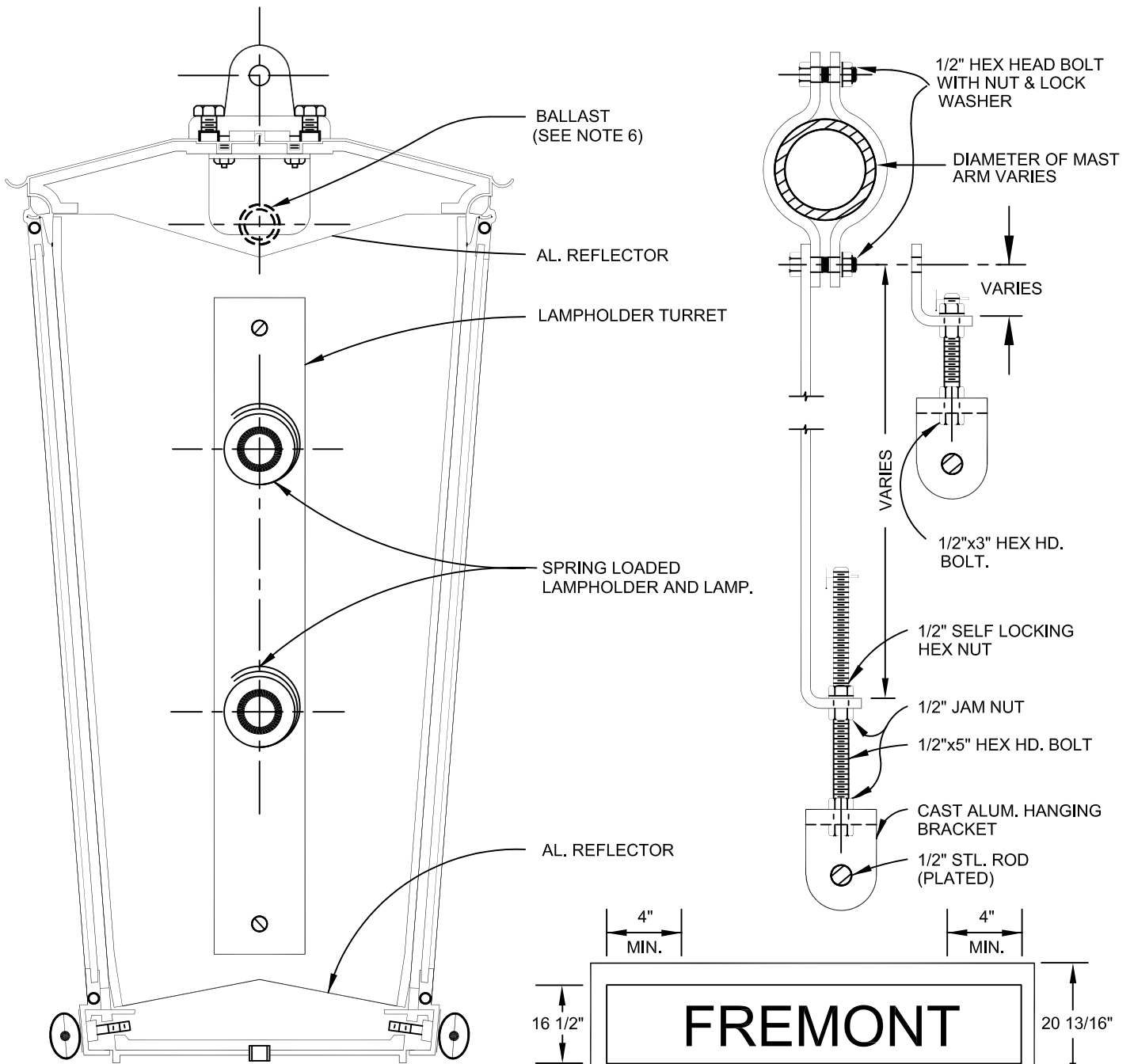

NOTES:

1. SIGN SHALL BE DOUBLE FACED.
2. SIGN PANEL SHALL BE WHITE WIDE-ANGLE PRISMATIC TRANSLUCENT CLASS 6 REFLECTIVE SHEETING, EITHER REVERSE-SCREENED WITH MANUFACTURER'S RECOMMENDED GREEN INK AND CLEAR COATING OR OVERLAYED WITH GREEN ELECTRONIC CUTABLE TRANSPARENT OVERLAY FILM, APPLIED TO A POLYCARBONATE CLEAR SUBSTRATE, 0.1875" GAGE.
3. LETTERS SHALL BE 8" SERIES E AND, UNLESS OTHERWISE SPECIFIED BY THE TRAFFIC ENGINEER, SHALL BE ALL UPPERCASE WITH NO STREET NAME SUFFIX. IF NECESSARY TO MAKE SPACING FIT, REDUCE TO 8" SERIES D. SPACING BETWEEN LETTERS MAY BE INCREASED BY UP TO 25% (MAX) TO ACHIEVE 4" END SPACES.
4. APPROVAL OF SHOP DRAWING OF SIGNFACE LAYOUT BY TRAFFIC ENGINEER IS REQUIRED PRIOR TO FABRICATION OF SIGN PANELS.
5. SHEETING SHALL BE APPLIED IN A VERTICAL ORIENTATION IN ACCORDANCE WITH MANUFACTURER'S RECOMMENDATION.
6. ADVANCE BALLAST RSM175STP FOR EACH FLUORESCENT TUBE IS REQUIRED AND NO SUBSTITUTES.

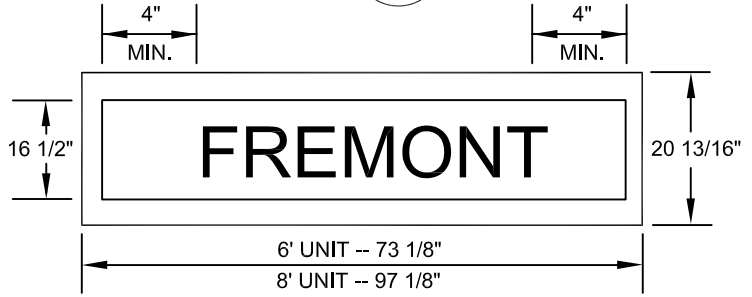

SPECIFICATION REFERENCE

UNIFORM STANDARD DRAWINGS
CLARK COUNTY AREA

STREET NAME SIGN
INTERNALLY ILLUMINATED

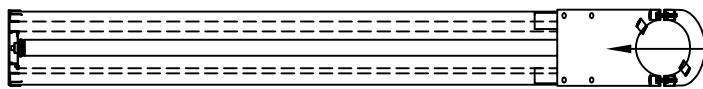

FLAG MOUNT BRACKET

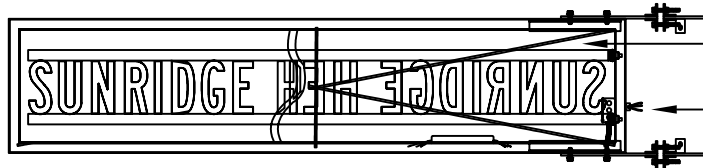

3/8" SUPPORT RODS TO PREVENT VERTICAL SAG OF CABINET

HANDI-BOX FOR INCOMING PRIMARY



STD. 12" EXTRUSION WITH 1-1/2" TOP HINGE RETAINER SYSTEM

STD. 8'-0" CWHO LAMPS ON 10" CENTERS HORIZONTALLY

WHITE POLYCARBONATE FACE

ALUMINUM PROP ROD FOR SERVICE BALLAST ATTACHED TO EXTRUDED WIREWAY

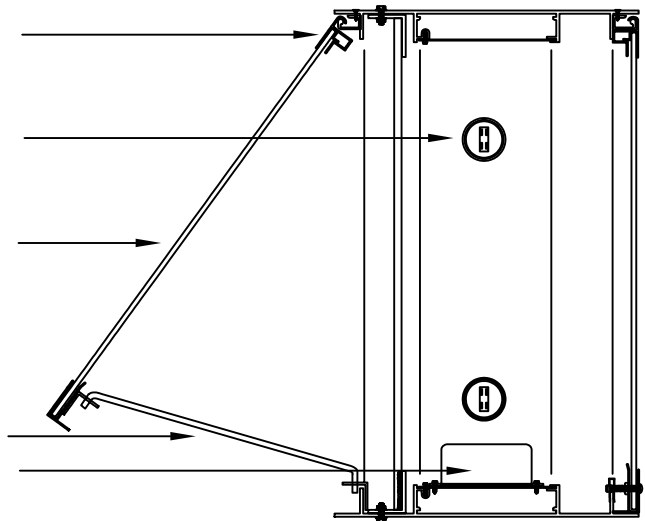

NOTES:

1. SIGN SHALL BE DOUBLE FACED.
2. ALUMINUM EXTRUSION CABINET 12" DEEP - MILL FINISH WITH ALL ALUMINUM INTERNAL STRUCTURE.
3. TOP-HINGED RETAINER SYSTEM WITH PROP ROD FOR ACCESS AND SERVICE.
4. T12 800MA CWHO FLUORESCENT ILLUMINATION INTERNALLY.
5. SIGN PANEL SHALL BE WHITE WIDE-ANGLE PRISMATIC TRANSLUCENT REFLECTIVE SHEETING, EITHER REVERSE-SCREENED WITH MANUFACTURER'S RECOMMENDED GREEN INK AND CLEAR COATING OR OVERLAYED WITH GREEN ELECTRONIC CUTTABLE TRANSPARENT OVERLAY FILM, APPLIED TO A POLYCARBONATE CLEAR SUBSTRATE, 0.177" THICK.
6. LETTERS SHALL BE 8" SERIES E AND UNLESS OTHERWISE SPECIFIED BY THE TRAFFIC ENGINEER, SHALL BE ALL UPPERCASE WITH NO STREET NAME SUFFIX. IF NECESSARY TO MAKE SPACING FIT, REDUCE TO 8" SERIES D. SPACING BETWEEN LETTERS MAY BE INCREASED BY UP TO 25% (MAX) TO ACHIEVE 4" END SPACES.
7. STEEL BRACKETS SHALL BE USED FOR FLAG MOUNT POLE ATTACHMENT.
8. THE USE OF THE POLE MOUNTED STREET NAME SIGN SHALL BE APPROVED BY THE ENTITY ENGINEER.

SPECIFICATION REFERENCE

UNIFORM STANDARD DRAWINGS
CLARK COUNTY AREA

ALTERNATIVE POLE MOUNTED STREET
NAME SIGN INTERNALLY ILLUMINATED

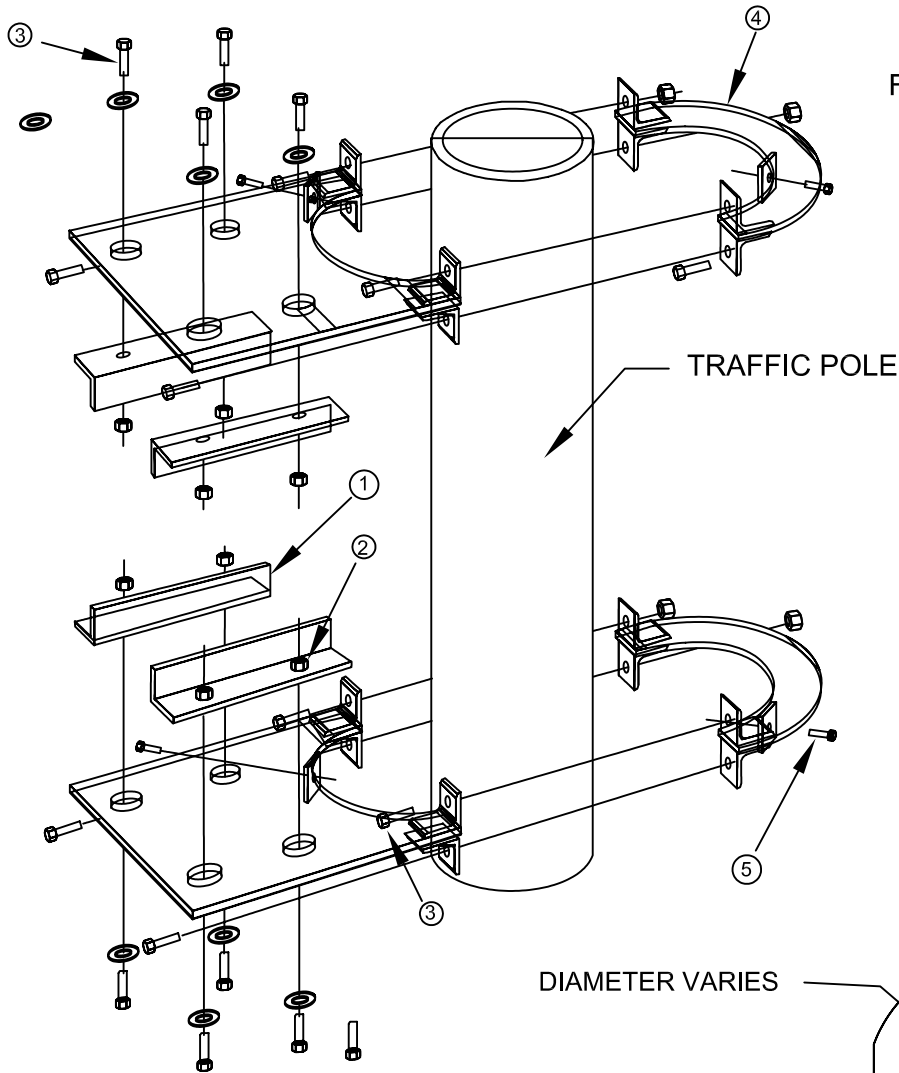

FLAG MOUNT ATTACHMENT DETAIL
NOT TO SCALE

- ① ALUMINUM ANGLE WELDED TO INSIDE OF EXTRUDED CABINET
- ② NUTS WELDED TO ANGLE
- ③ 1/2" X 1 1/2" BOLTS
- ④ BRACKET FABRICATED FROM 3/8" PLATE STEEL
- ⑤ 5/16" SET SCREWS INTO POLE

BRACKET DETAIL
NOT TO SCALE

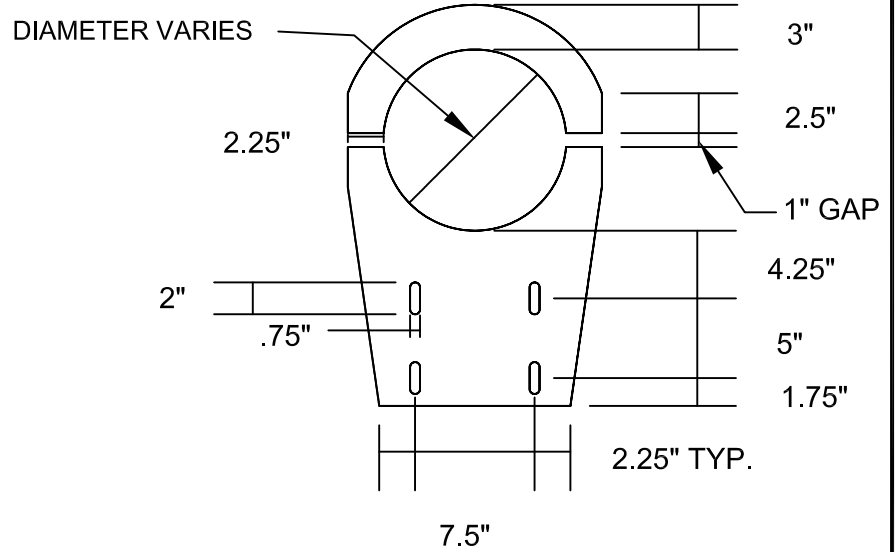

SPECIFICATION REFERENCE

UNIFORM STANDARD DRAWINGS
CLARK COUNTY AREA

ALTERNATIVE POLE MOUNTED STREET
NAME SIGN INTERNALLY ILLUMINATED
ATTACHMENT DETAIL

DATE 11/10/05

DWG. NO.

404.417A

SHT 2 OF 3

INSTALLATION INSTRUCTIONS

- * ATTACH BRACKETS ① TO CABINET END AT TOP AND BOTTOM WITH BOLTS PROVIDED LOSSELY TIGHTEN BOLTS (SNUG).
- * LIFT CABINET WITH BRACKETS TO POLE AT FINISHED HEIGHT USING A NYLON LIFTING SNAP NEAR THE BRACKETS (WHERE BALANCED).
- * ATTACH BRACKET HALVES ② TOGETHER AROUND POLE WITH PROVIDED HARDWARE AS SHOWN.
- * MOVE LIFTING STRIP TO CENTER OF CABINET & LEVEL THEN TIGHTEN BOLTS INTO CABINET.
- * ATTACH SET SCREWS ③ THROUGH BRACKET INTO POLE AS SHOWN.
- * HOOK UP ELECTRICAL CONNECTION (SEE PAGE 2 FOR AN EXAMPLE).

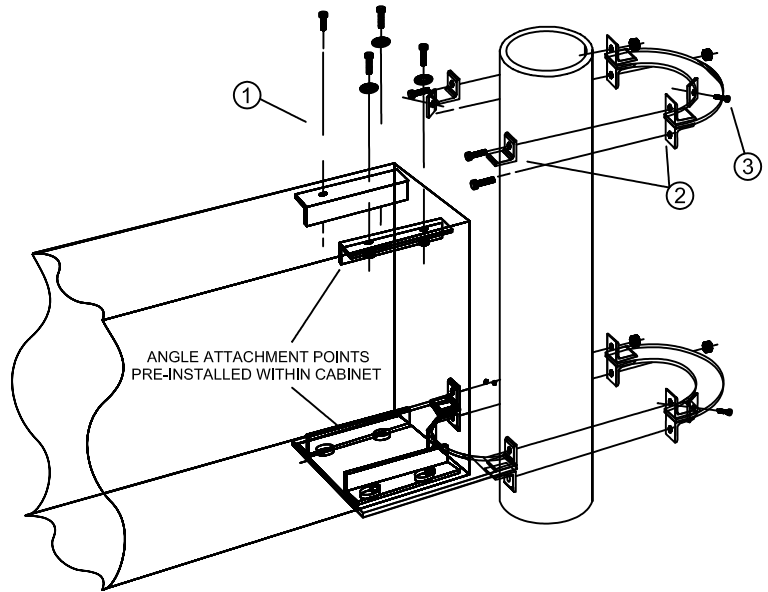

WIRING RECOMMENDATIONS

- * LOCATE & DRILL A 3/4" DIA. HOLE ① THRU POLE. THREAD HOLE WITH 1/2" PIPE THREAD TAP.
- * PULL WIRES FROM GROUND THRU TAPPED HOLE GUIDE WIRES TO AVOID SCRAPING INSULATION.
- * ASSEMBLE LIQUID TIGHT 1/2" CONDUIT ② & FITTING ③ TO CONNECT POLE TO CABINET.
- * FEED WIRES THRU CONDUIT & INTO CABINET, USE A 2X4 HANDY BOX INSIDE OF CABINET TO FACILITATE WIRE PULLING.
- * AFTER FEEDING WIRES, THEN THREAD FITTINGS INTO THREADED HOLE IN POLE & CABINET.
- * WIRE BALLAST INSIDE CABINET AS REQUIRED.

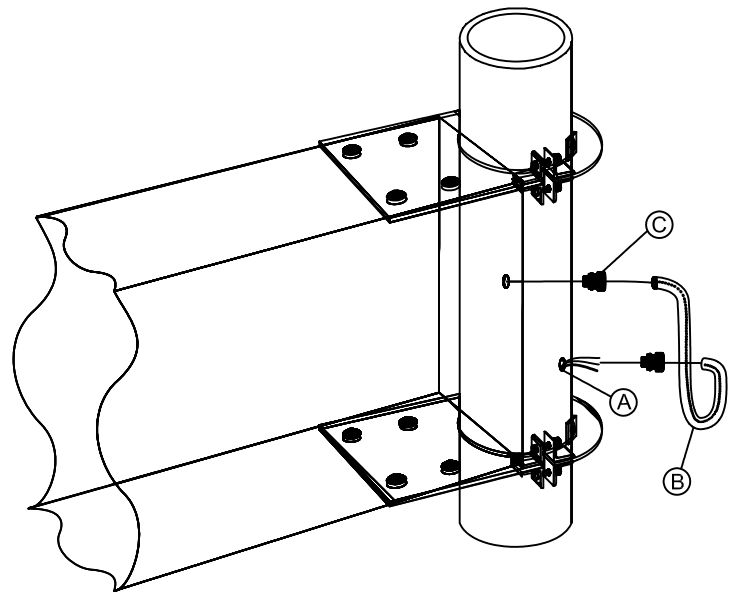

NOTE: THE STREET NAME SIGN SHALL BE MOUNTED 18" ABOVE THE MAST ARM

SPECIFICATION REFERENCE

UNIFORM STANDARD DRAWINGS
CLARK COUNTY AREA

ALTERNATIVE POLE MOUNTED STREET
NAME SIGN INTERNALLY ILLUMINATED
BRACKET DETAIL

DATE 11/10/05 | DWG. NO. 404.417A | SHT 3 OF 3

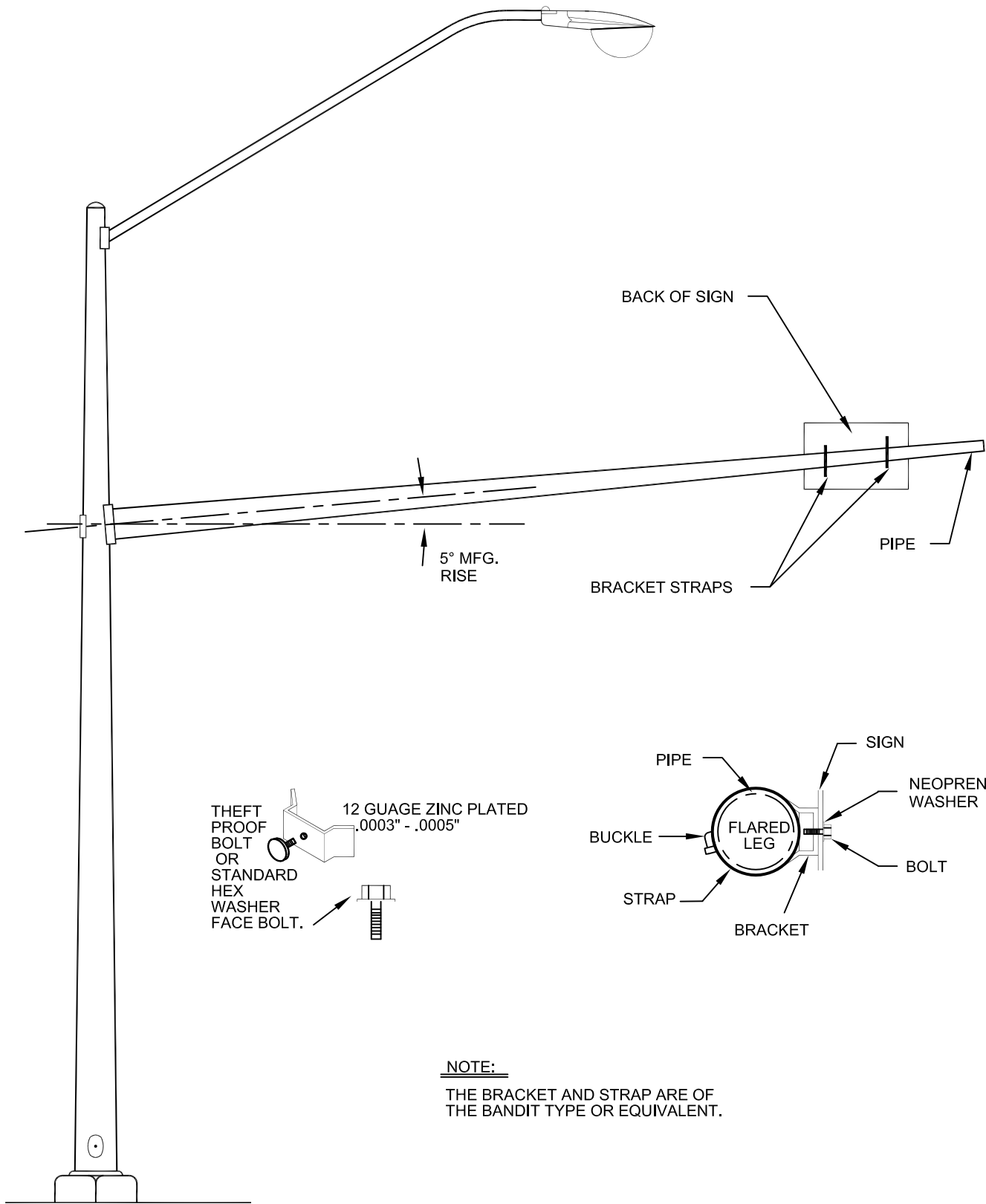

THEFT PROOF BOLT OR STANDARD HEX WASHER FACE BOLT.

12 GAUGE ZINC PLATED
.0003" - .0005"

NOTE:
THE BRACKET AND STRAP ARE OF THE BANDIT TYPE OR EQUIVALENT.

SPECIFICATION REFERENCE

UNIFORM STANDARD DRAWINGS
CLARK COUNTY AREA

SIGN MOUNTING
ILLUSTRATION

DATE	4-9-98	DWG. NO.	404.418	SHEET	1 OF 1
------	--------	----------	---------	-------	--------

Effective 01/01/09 - 06/30/09

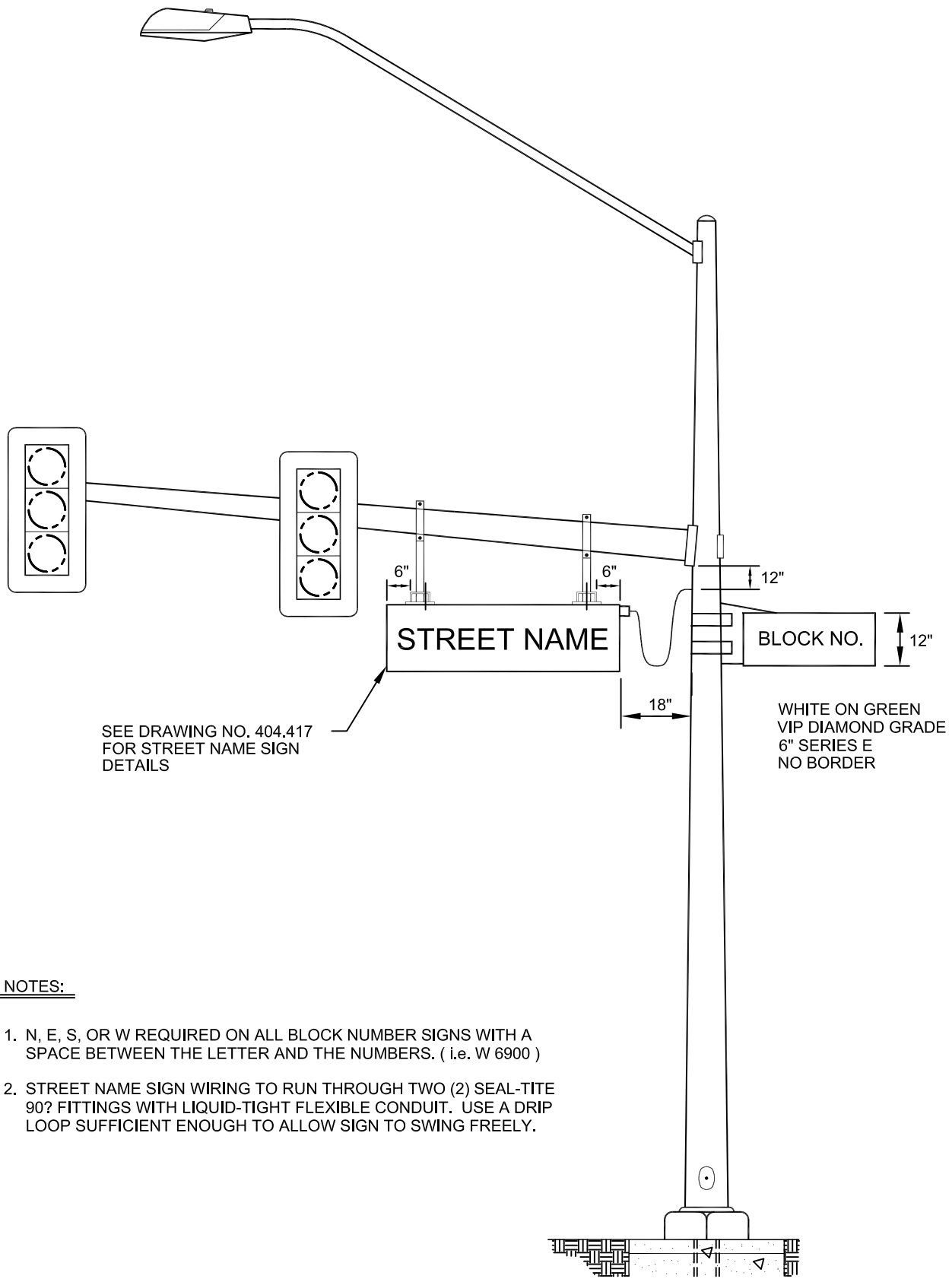

SEE DRAWING NO. 404.417
FOR STREET NAME SIGN
DETAILS

WHITE ON GREEN
VIP DIAMOND GRADE
6" SERIES E
NO BORDER

NOTES:

1. N, E, S, OR W REQUIRED ON ALL BLOCK NUMBER SIGNS WITH A SPACE BETWEEN THE LETTER AND THE NUMBERS. (i.e. W 6900)
2. STREET NAME SIGN WIRING TO RUN THROUGH TWO (2) SEAL-TITE 90° FITTINGS WITH LIQUID-TIGHT FLEXIBLE CONDUIT. USE A DRIP LOOP SUFFICIENT ENOUGH TO ALLOW SIGN TO SWING FREELY.

SPECIFICATION REFERENCE

UNIFORM STANDARD DRAWINGS
CLARK COUNTY AREA

BLOCK NUMBER SIGN

DATE	4-9-98	DWG. NO.	404.420	SHEET	1 OF 1
------	--------	----------	---------	-------	--------

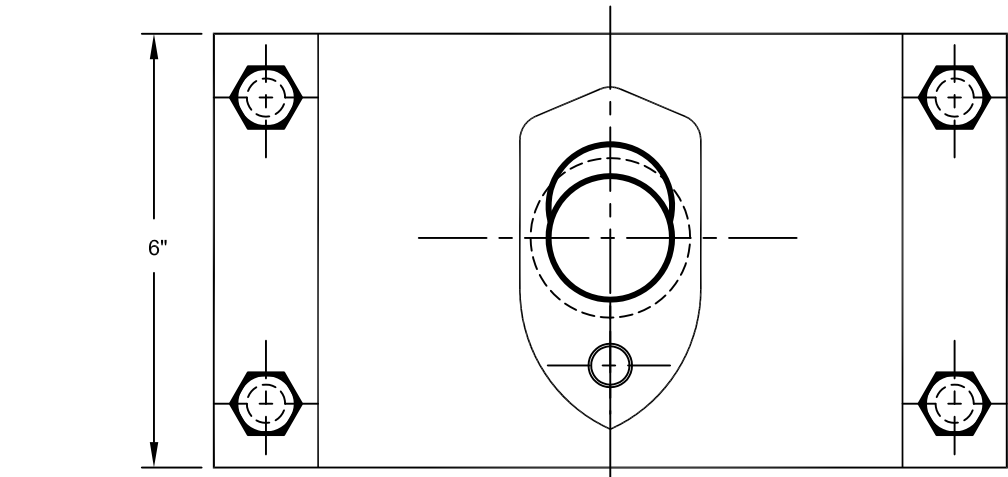
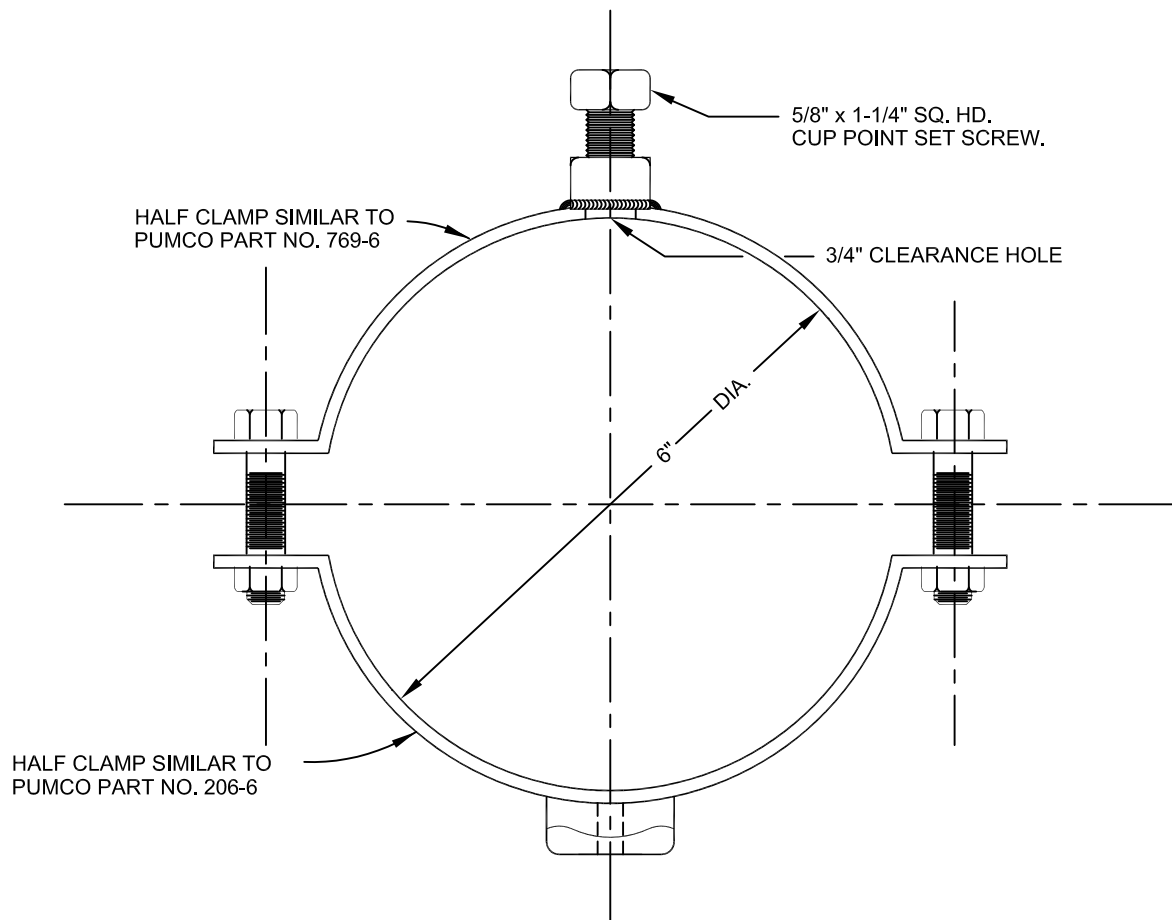

NOTES:

1. COMPLETE ASSEMBLY SHALL BE HOT-DIP GALVANIZED OR PRIME-PAINTED AS REQUIRED BY THE ENTITY.
2. COMPLETE ASSEMBLY SIMILAR TO PUMCO PART NO. 207-769-6.
3. THIS ASSEMBLY TO BE USED ON EXISTING 30' POLES ONLY.

SPECIFICATION REFERENCE	UNIFORM STANDARD DRAWINGS CLARK COUNTY AREA			
	ONE BOLT SIMPLEX ARM ATTACHMENT CLAMP ASSEMBLY			
	DATE	12-12-96	DWG. NO.	404.502
	SHEET		1 OF 1	

Effective 01/01/09 - 06/30/09

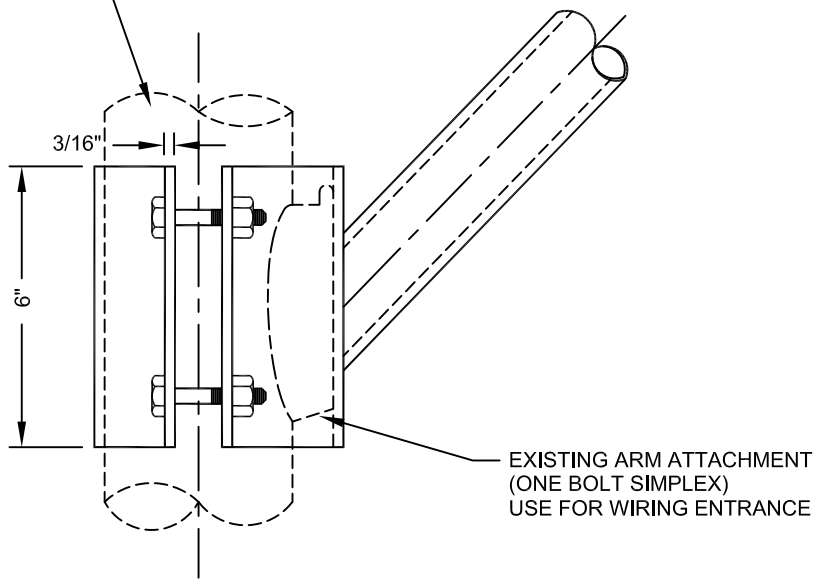
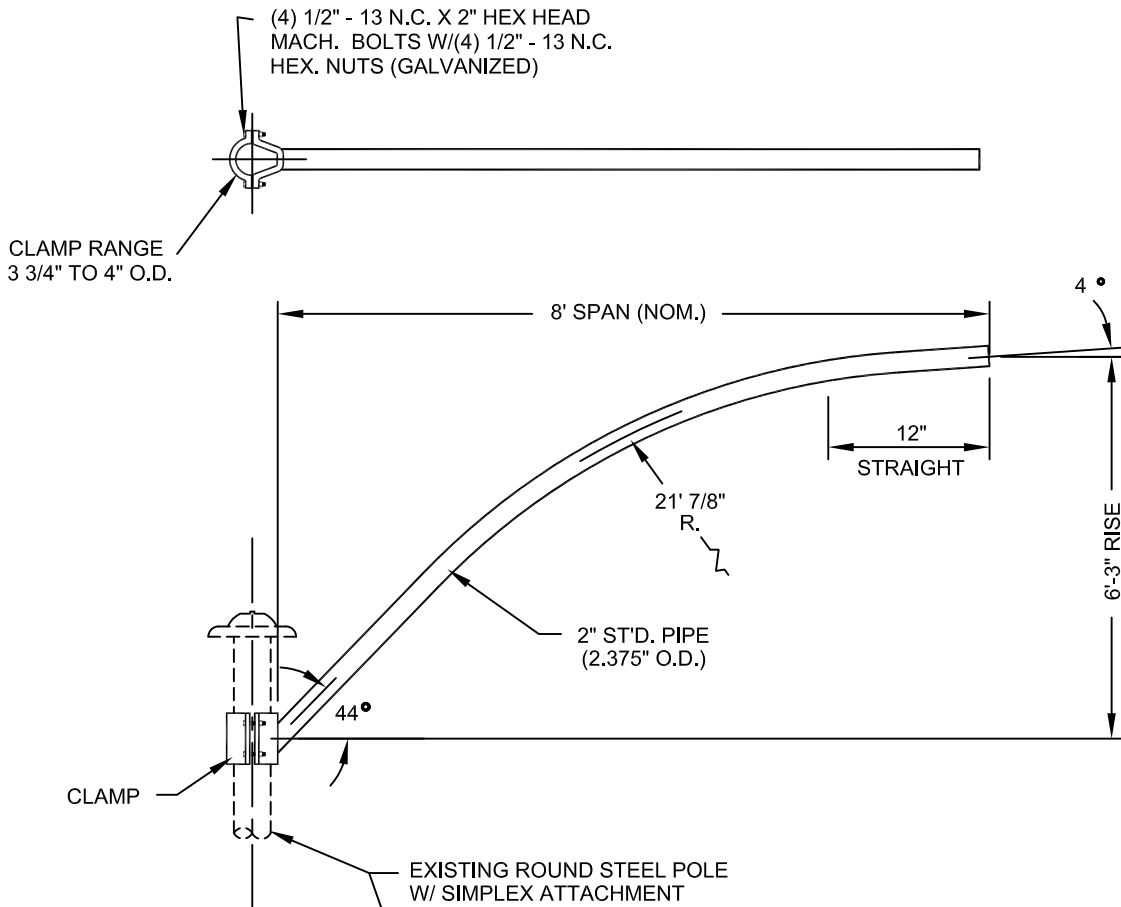

BRACKET RATING
 MAX. LUMINAIRE AREA = 2.7 FT²
 MAX. LUMINAIRE WT. = 57 LBS.

SPECIFICATION REFERENCE

UNIFORM STANDARD DRAWINGS
 CLARK COUNTY AREA

RETROFIT STREETLIGHT
 MAST ARM

(NO SCALE)

SPECIAL NOTE:
POLE SHALL
NOT BE DRILLED
FOR CLAMSHELL
UNTIL AFTER
INSTALLATION
OF POLE.

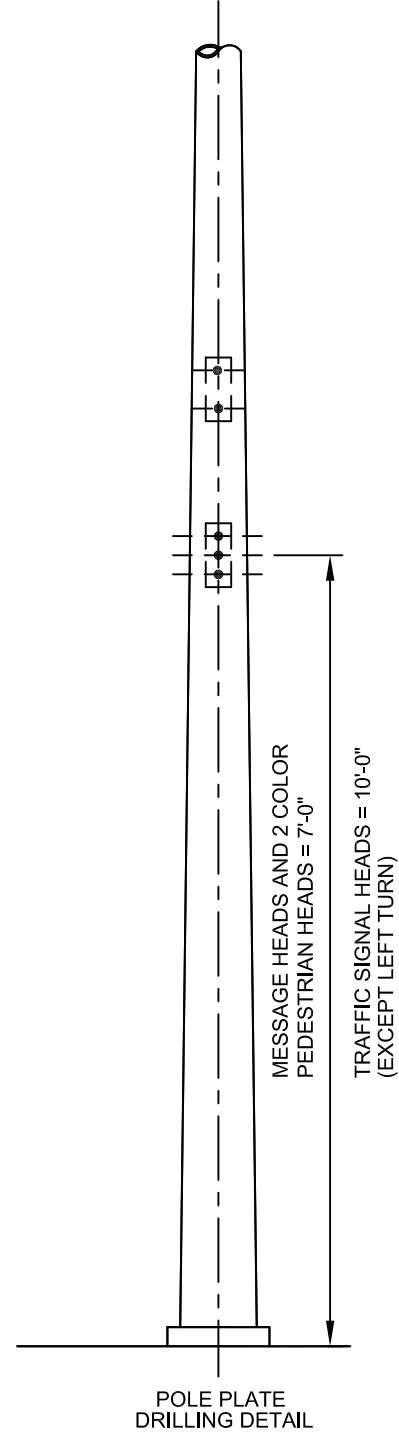
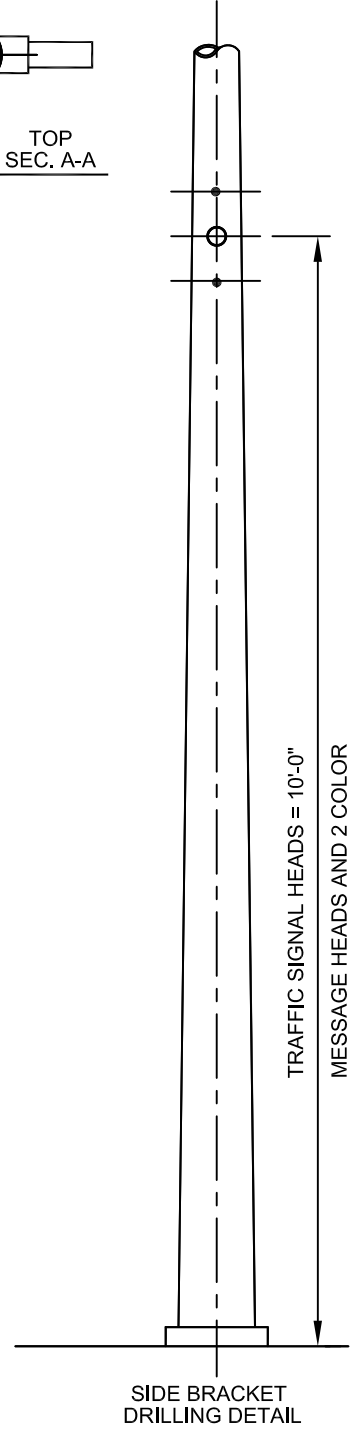
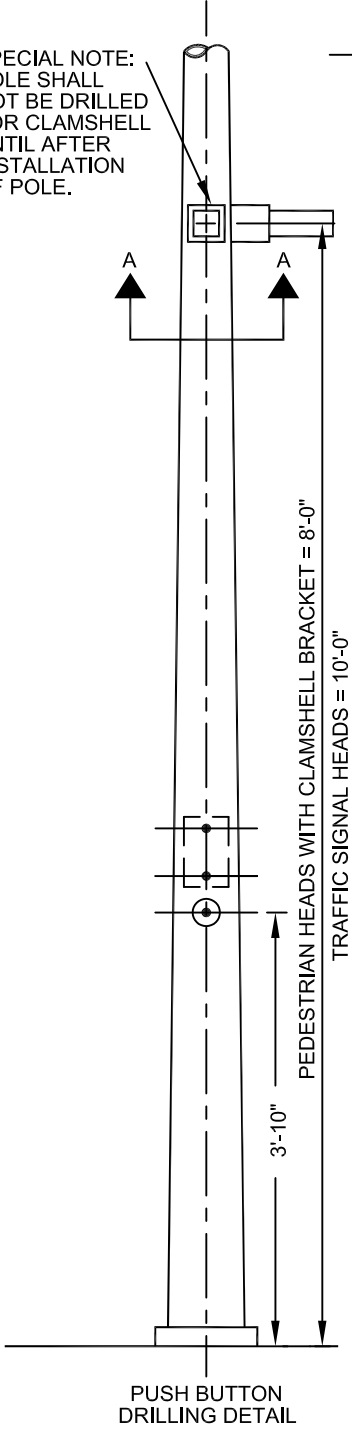
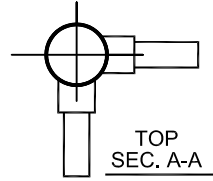

NOTES:

1. DRILLING OF POLE TO BE ORIENTED ACCORDING TO POLE LAYOUT, SPECIFICATIONS, AND AND ENGINEER.
2. DIMENSIONS ARE FROM CURB LEVEL.
3. DIMENSIONS ARE TO WIRE INLET HOLE ONLY. USE MANUFACTURER'S TEMPLATE TO LOCATE ALL OTHER HOLES.
4. ALL HOLES ARE TO CONFORM TO MANUFACTURER'S RECOMMENDATIONS.

SPECIFICATION REFERENCE

UNIFORM STANDARD DRAWINGS
CLARK COUNTY AREA

POLE DRILLING
DETAILS

SIGNAL ASSEMBLY A-10T

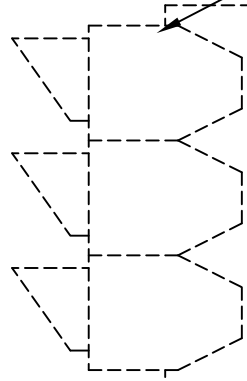

1/2" - 13 NC HEX. HEAD BOLT & NUT CADMIUM - PLATED OR GALVANIZED

DRILL 9/16" HOLES

FLAT WASHER

2 1/2"
2 1/2"

SIGNAL ASSEMBLY B-10

TYPE 1-A STANDARD
DRAWING NO. 404.402

FLAT WASHER

WASHERS CURVED TO FIT STANDARD

DRILL 9/16" HOLES

3'-8"

4'-6"

10' MIN.
TO NOSE
OF ISLAND

SPECIFICATION REFERENCE

UNIFORM STANDARD DRAWINGS
CLARK COUNTY AREA

ISLAND SIGNAL POLE
DETAILS FOR 10' POLE

DATE

DWG. NO. 404.601

SHEET 1 OF 1

Effective 01/01/09 - 06/30/09

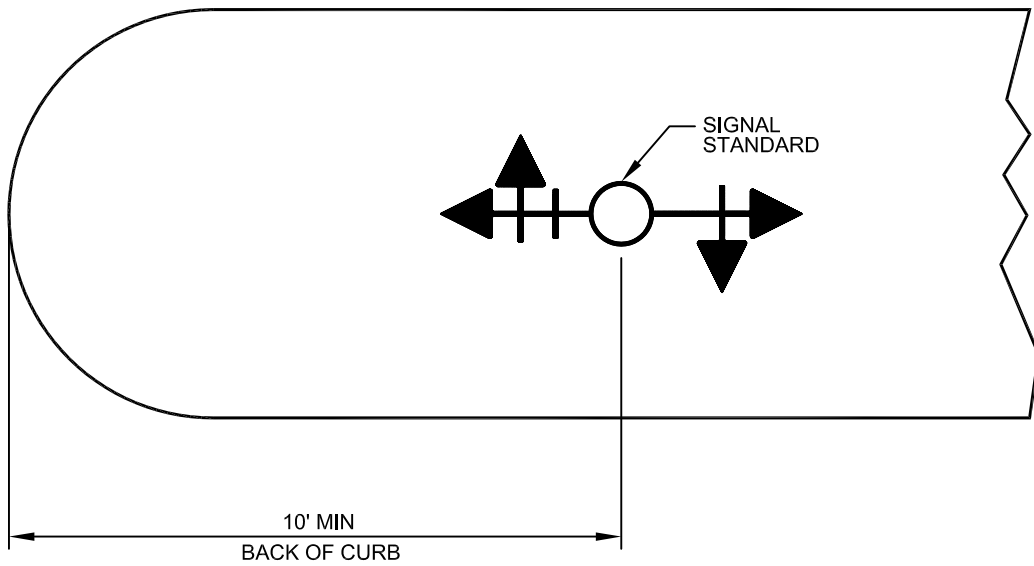

NOTE:

FOR POLE LOCATION ON RIGHT TURN ISLAND SEE DRAWING NO. 404.1301.

	SPECIFICATION REFERENCE

UNIFORM STANDARD DRAWINGS
CLARK COUNTY AREA

MEDIAN ISLAND
SIGNAL LOCATION

DATE

DWG. NO.

404.700

SHEET

1 OF 1



DIRECTION OF TRAVEL

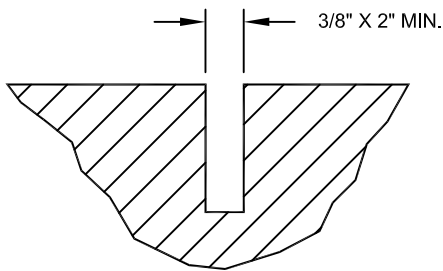
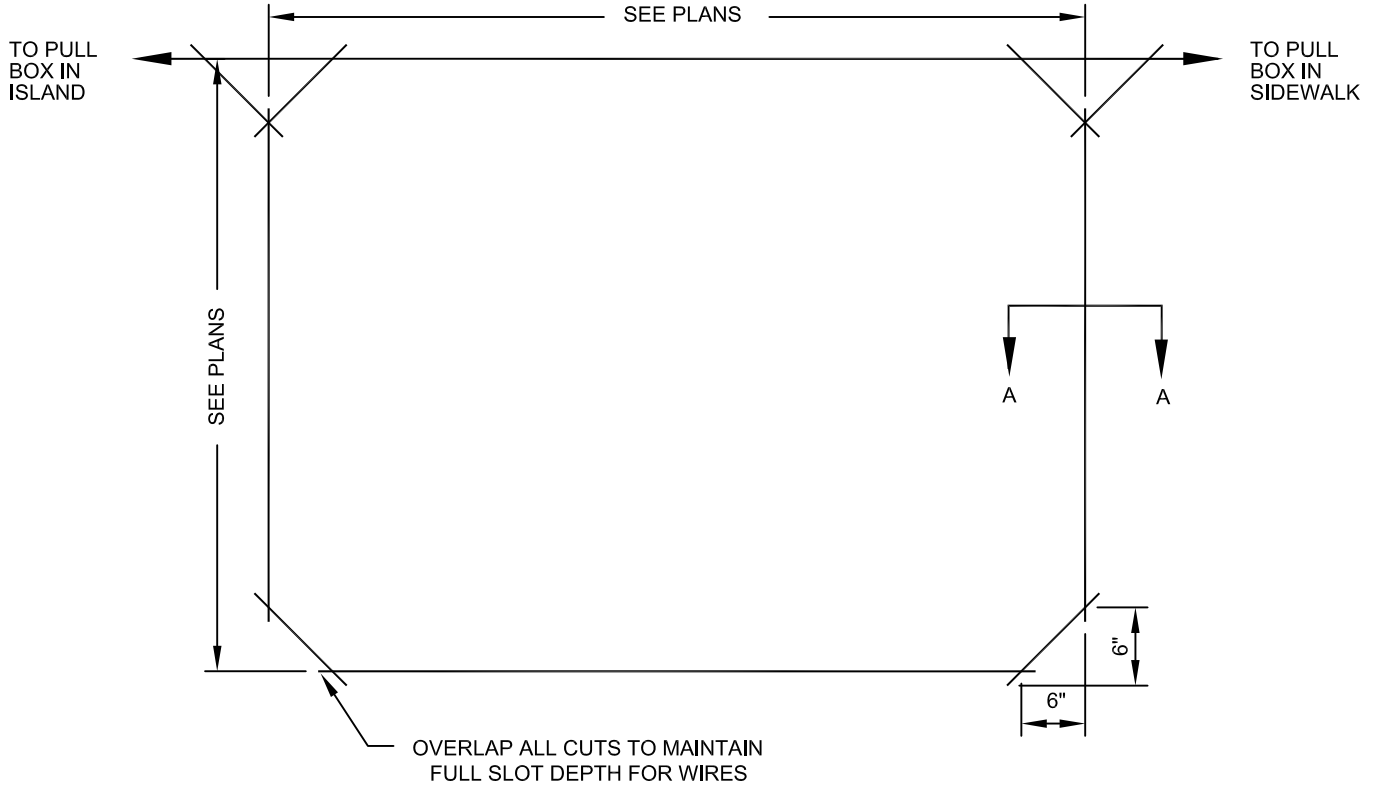

A-A

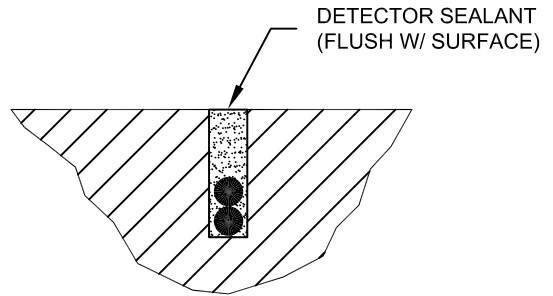

A-A (AFTER INSTALLATION)

SPECIFICATION REFERENCE

UNIFORM STANDARD DRAWINGS
CLARK COUNTY AREA

SAWCUT DETAILS
FOR INDUCTION LOOPS

DATE

DWG. NO. 404.810

SHEET 1 OF 1

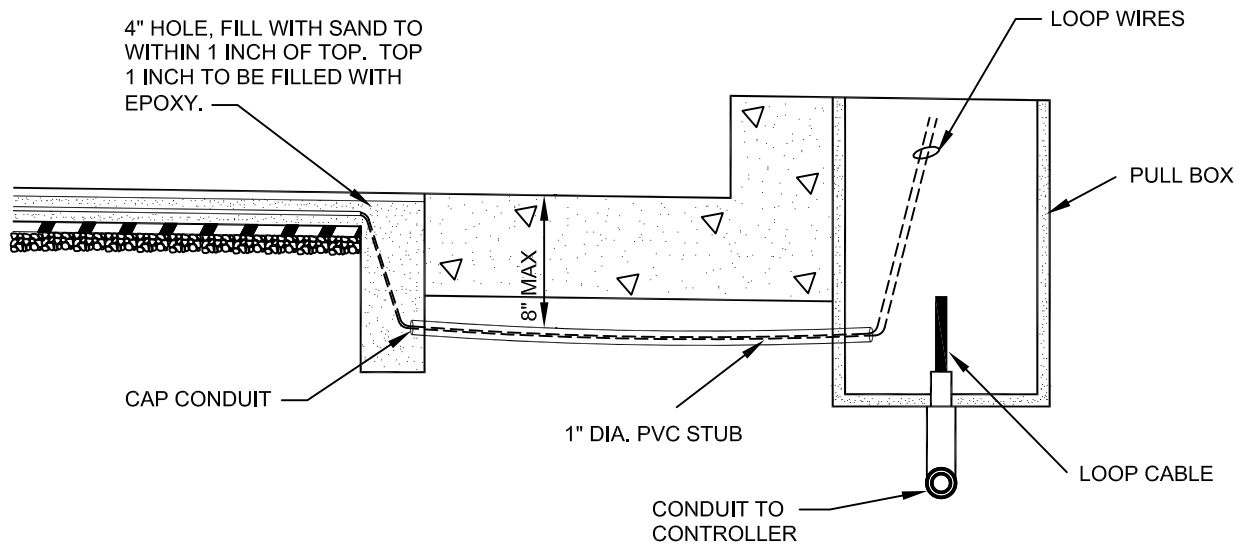

NOTE:

PATCH SLOT AND HOLE WITH EPOXY, REMOVE OVERFLOW BEFORE IT HARDENS.

SPECIFICATION REFERENCE

UNIFORM STANDARD DRAWINGS
CLARK COUNTY AREA

DETAILS @ PULL BOX
AND SAWCUTS

DATE

DWG. NO. 404.811

SHEET 1 OF 1

NOTE:

1. 4 TURNS OF WIRE SHOWN. ALWAYS INSTALL 4 TURNS OF CABLE IN DUCT UNLESS OTHERWISE SPECIFIED ON THE PLANS. WINDING DIRECTION SHALL BE INDICATED ON WIRE.

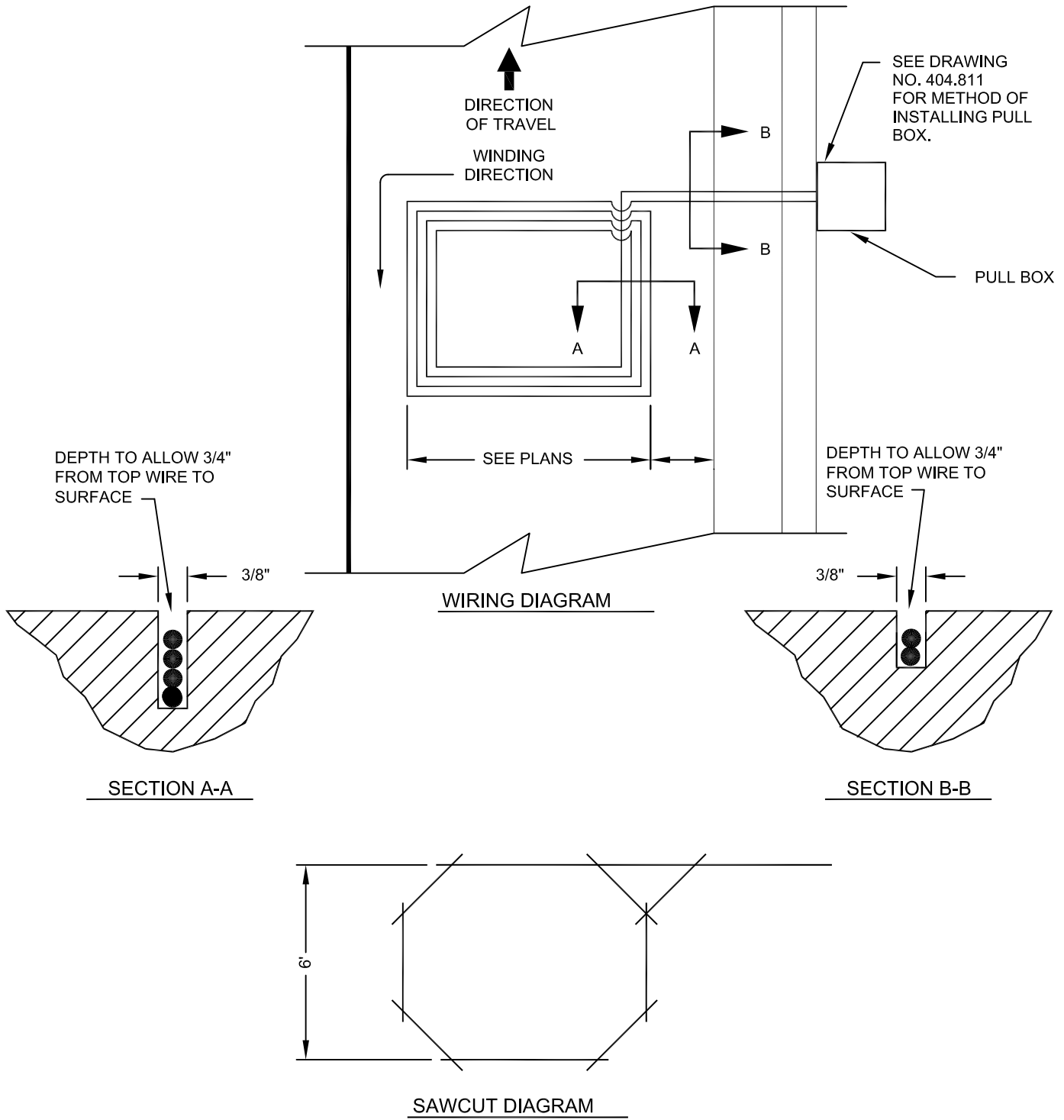

SEE DRAWING NO. 404.810 FOR SAWCUT DETAILS.

SPECIFICATION REFERENCE		UNIFORM STANDARD DRAWINGS CLARK COUNTY AREA		
		1 INDUCTION LOOP FOR 1 TRAVEL LANE		
DATE	DWG. NO.	404.820	SHEET	1 OF 1

NOTE:

2 TURNS OF WIRE SHOWN. ALWAYS INSTALL 2 TURNS OF CABLE IN DUCT UNLESS OTHERWISE SPECIFIED ON PLANS. WINDING DIRECTION SHALL BE INDICATED ON WIRE.

SEE DRAWING NO. 404.811 FOR METHOD OF INSTALLING PULL BOX

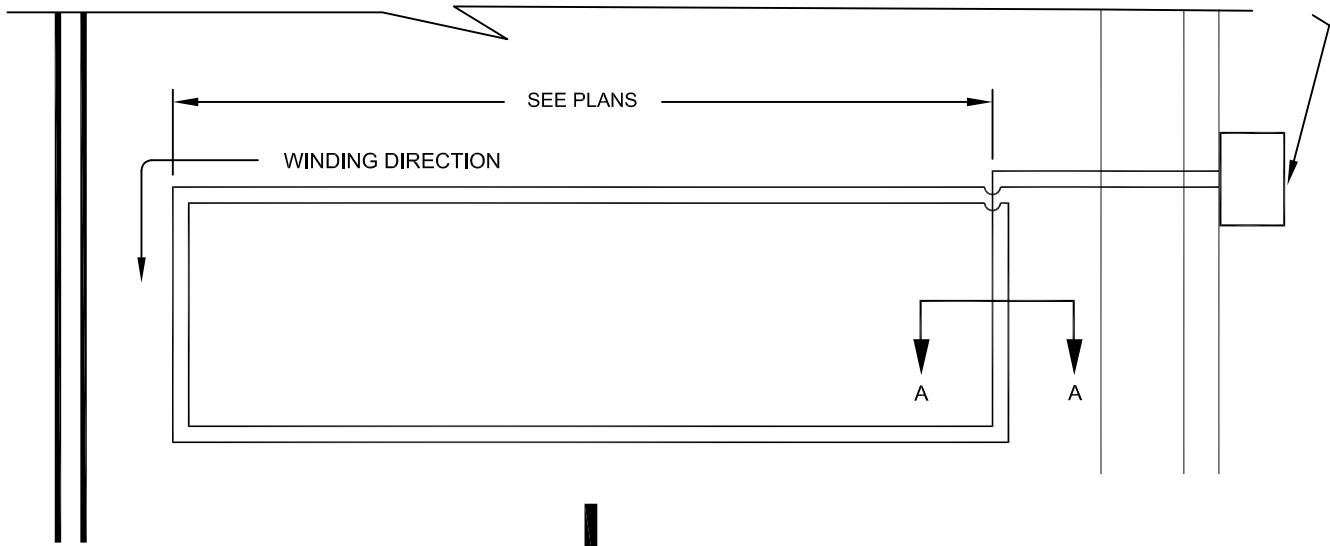

DIRECTION OF TRAVEL

DIRECTION OF TRAVEL

WIRING DIAGRAM

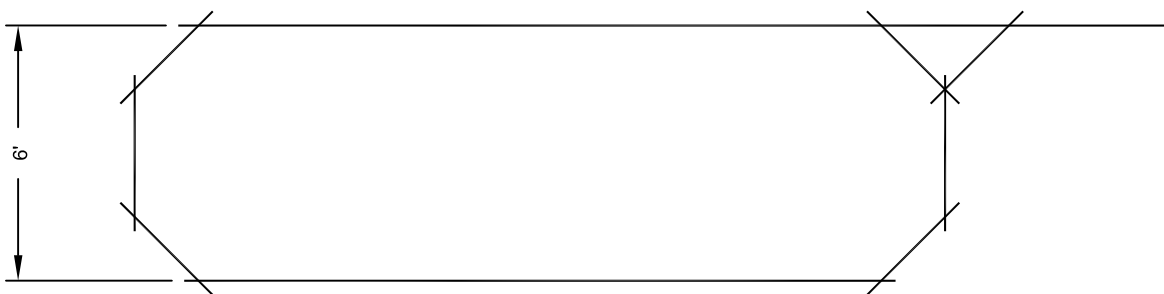
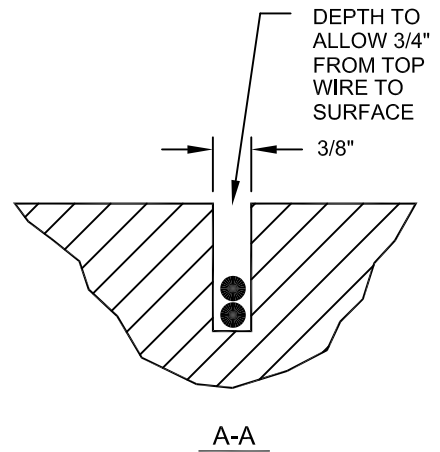

SAWCUT DIAGRAM

SEE DRAWING NO. 404.810 FOR SAWCUT DETAILS.

SPECIFICATION REFERENCE

UNIFORM STANDARD DRAWINGS
CLARK COUNTY AREA

1 INDUCTION LOOP
FOR 2 TRAVEL LANES

DATE

DWG. NO. 404.821

SHEET

1 OF 2

NOTE:

2 TURNS OF WIRE SHOWN. ALWAYS INSTALL 2 TURNS OF CABLE IN DUCT UNLESS OTHERWISE SPECIFIED ON PLANS. WINDING DIRECTION SHALL BE INDICATED ON WIRE.

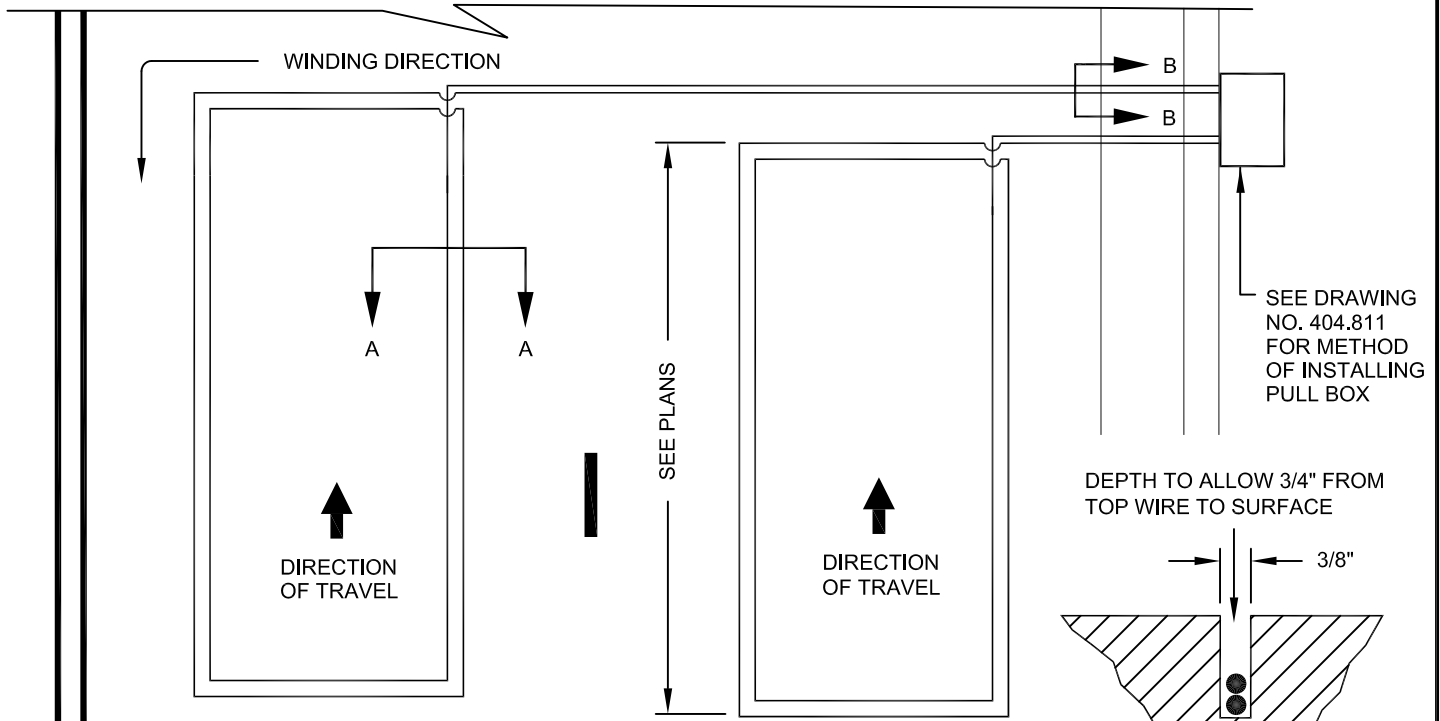

WIRING DIAGRAM

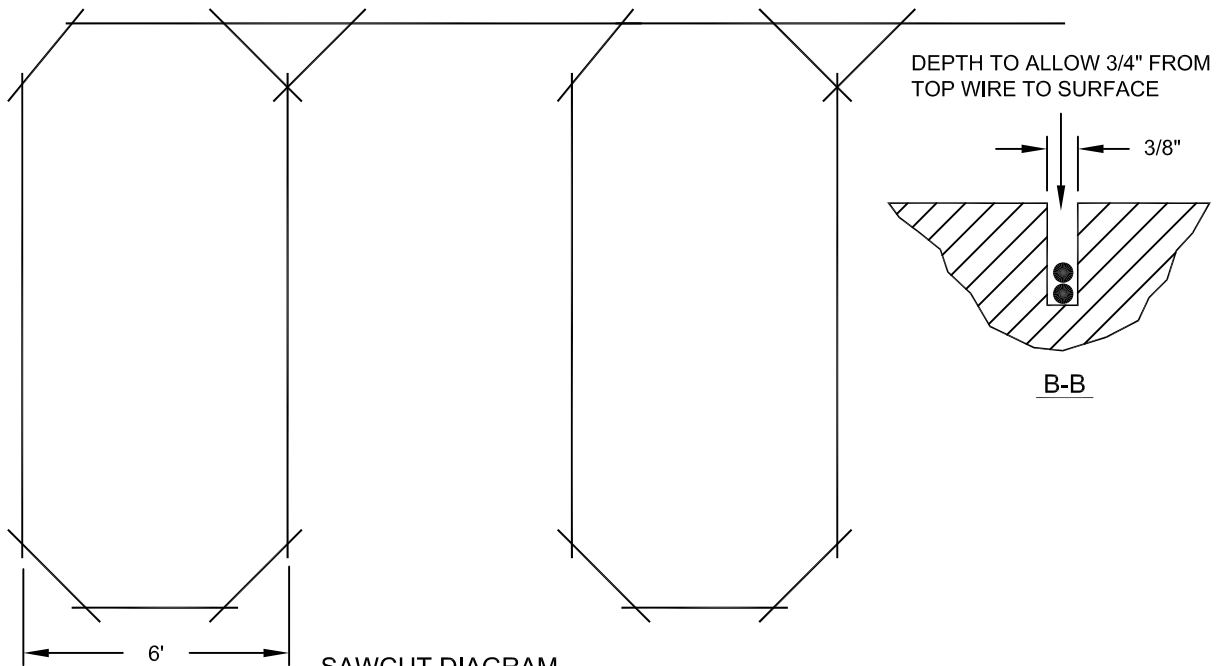

SAWCUT DIAGRAM

SEE DRAWING NO. 404.810 FOR SAWCUT DETAILS.

SPECIFICATION REFERENCE

UNIFORM STANDARD DRAWINGS
CLARK COUNTY AREA

2 INDUCTION LOOPS
FOR 2 TRAVEL LANES

DATE

DWG. NO. 404.821

SHEET 2 OF 2

NOTE:

2 TURNS OF WIRE SHOWN. ALWAYS INSTALL 2 TURNS OF CABLE IN DUCT UNLESS OTHERWISE SPECIFIED ON PLANS. WINDING DIRECTION SHALL BE INDICATED ON WIRE.

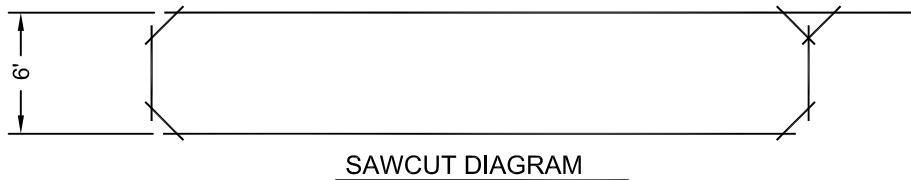
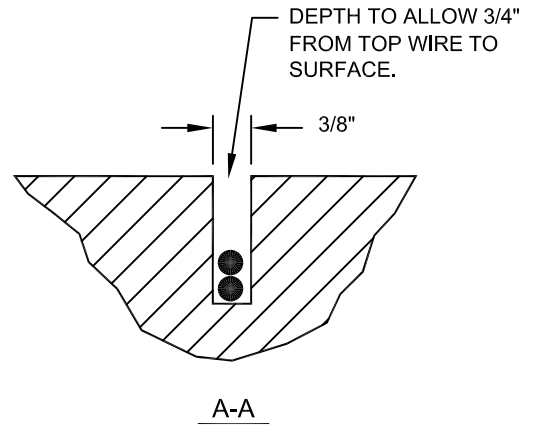
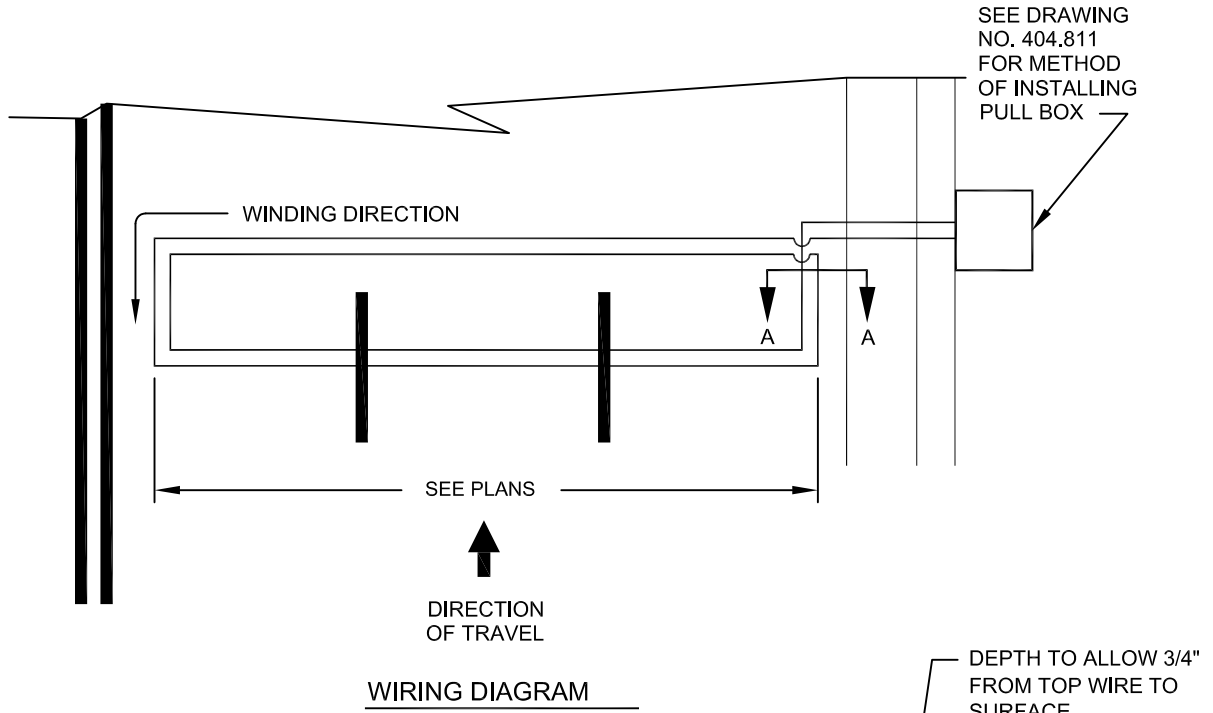

SEE DRAWING NO. 404.810 FOR SAWCUT DETAILS.

SPECIFICATION REFERENCE		UNIFORM STANDARD DRAWINGS CLARK COUNTY AREA		
		1 INDUCTION LOOP FOR 3 TRAVEL LANES		
DATE	DWG. NO.	404.822	SHEET	1 OF 2

NOTE:

2 TURNS OF WIRE SHOWN. ALWAYS INSTALL 2 TURNS OF CABLE IN DUCT UNLESS OTHERWISE SPECIFIED ON PLANS. WINDING DIRECTION SHALL BE INDICATED ON WIRE.

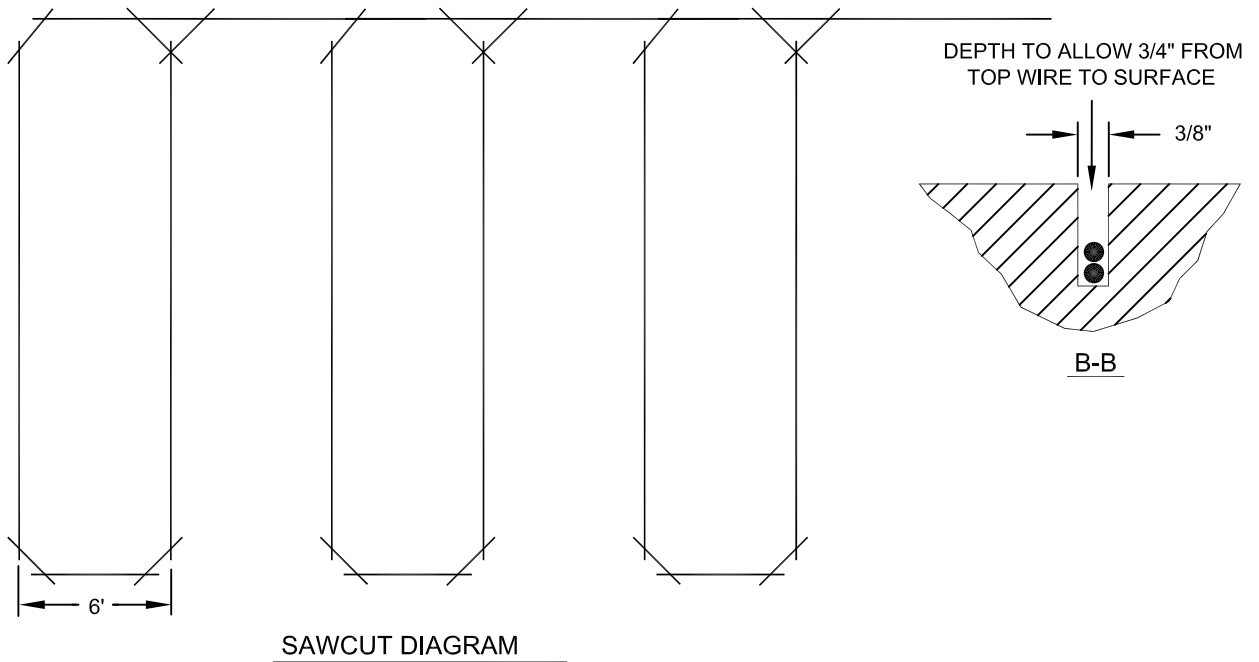
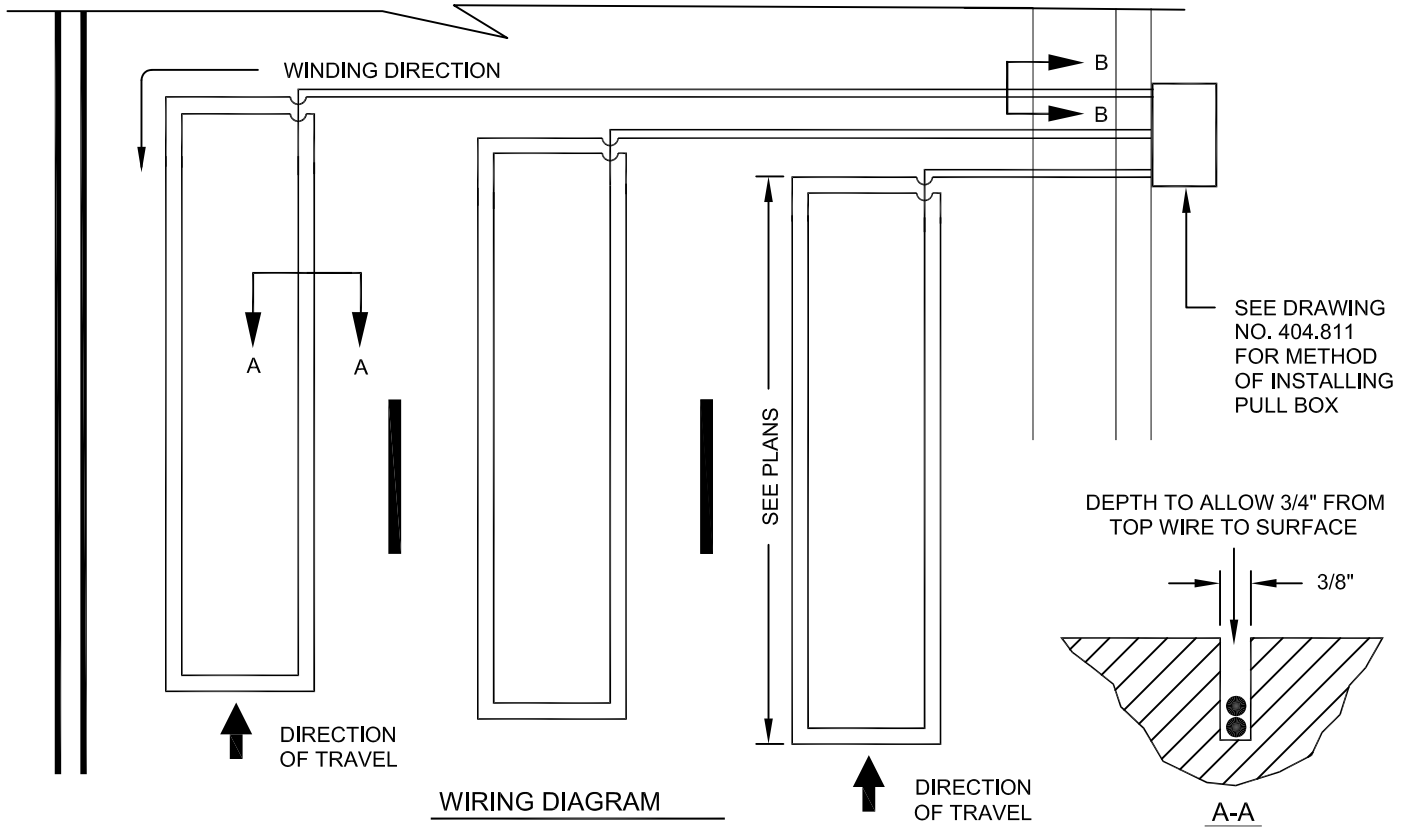

SEE DRAWING NO. 404.810 FOR SAWCUT DETAILS.

SPECIFICATION REFERENCE

UNIFORM STANDARD DRAWINGS
CLARK COUNTY AREA

3 INDUCTION LOOPS
FOR 3 TRAVEL LANES

DATE

DWG. NO. 404.822

SHEET

2 OF 2

NOTE:

2 TURNS OF WIRE SHOWN. ALWAYS INSTALL 2 TURNS OF CABLE IN DUCT UNLESS OTHERWISE SPECIFIED ON PLANS. WINDING DIRECTION SHALL BE INDICATED ON WIRE.

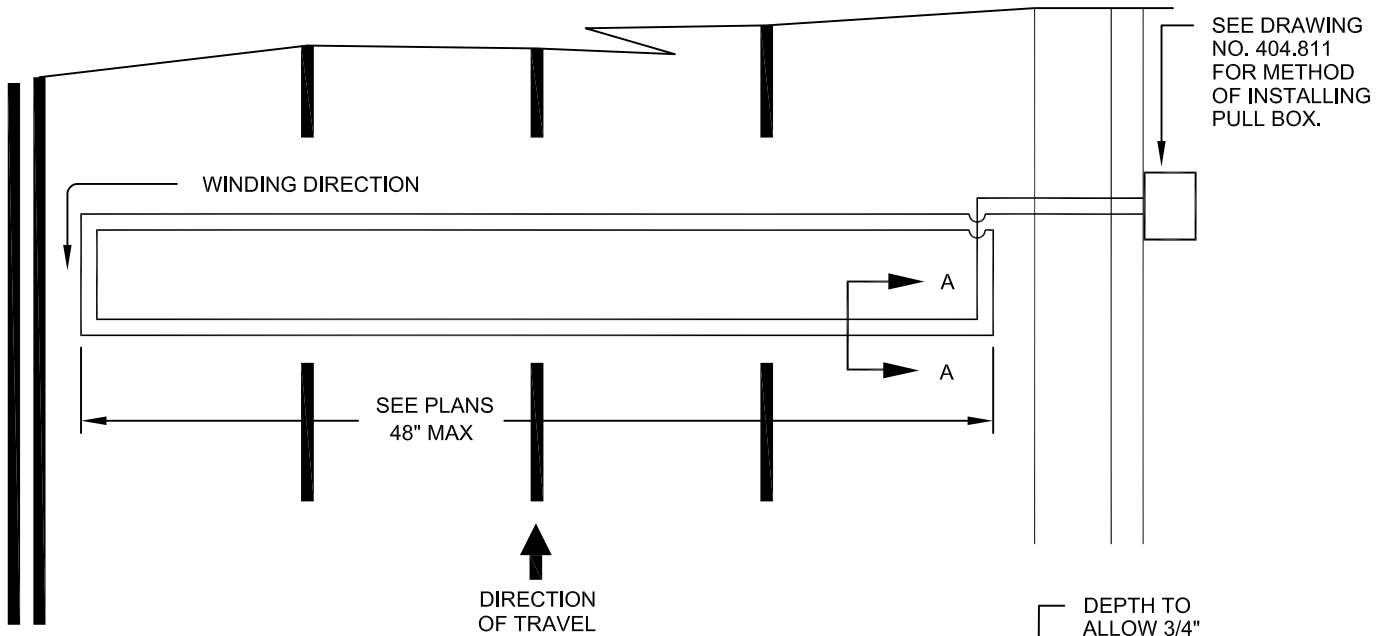

WIRING DIAGRAM

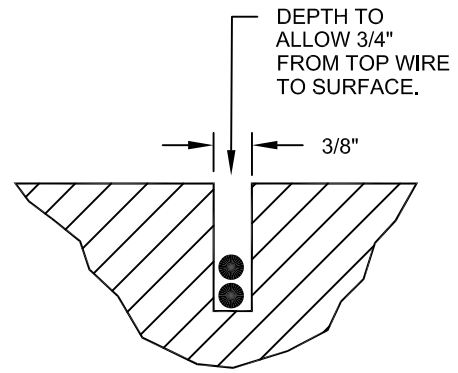

A-A

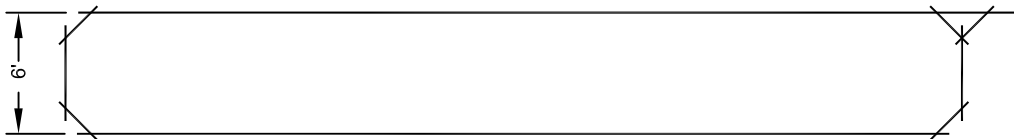

SAWCUT DIAGRAM

SEE DRAWING NO. 404.810 FOR SAWCUT DETAILS.

SPECIFICATION REFERENCE

UNIFORM STANDARD DRAWINGS
CLARK COUNTY AREA

1 INDUCTION LOOP
FOR 4 TRAVEL LANES

DATE

DWG. NO. 404.823

SHEET

1 OF 2

NOTE:

2 TURNS OF WIRE SHOWN. ALWAYS INSTALL 2 TURNS OF CABLE IN DUCT UNLESS OTHERWISE SPECIFIED ON PLANS. WINDING DIRECTION SHALL BE INDICATED ON WIRE.

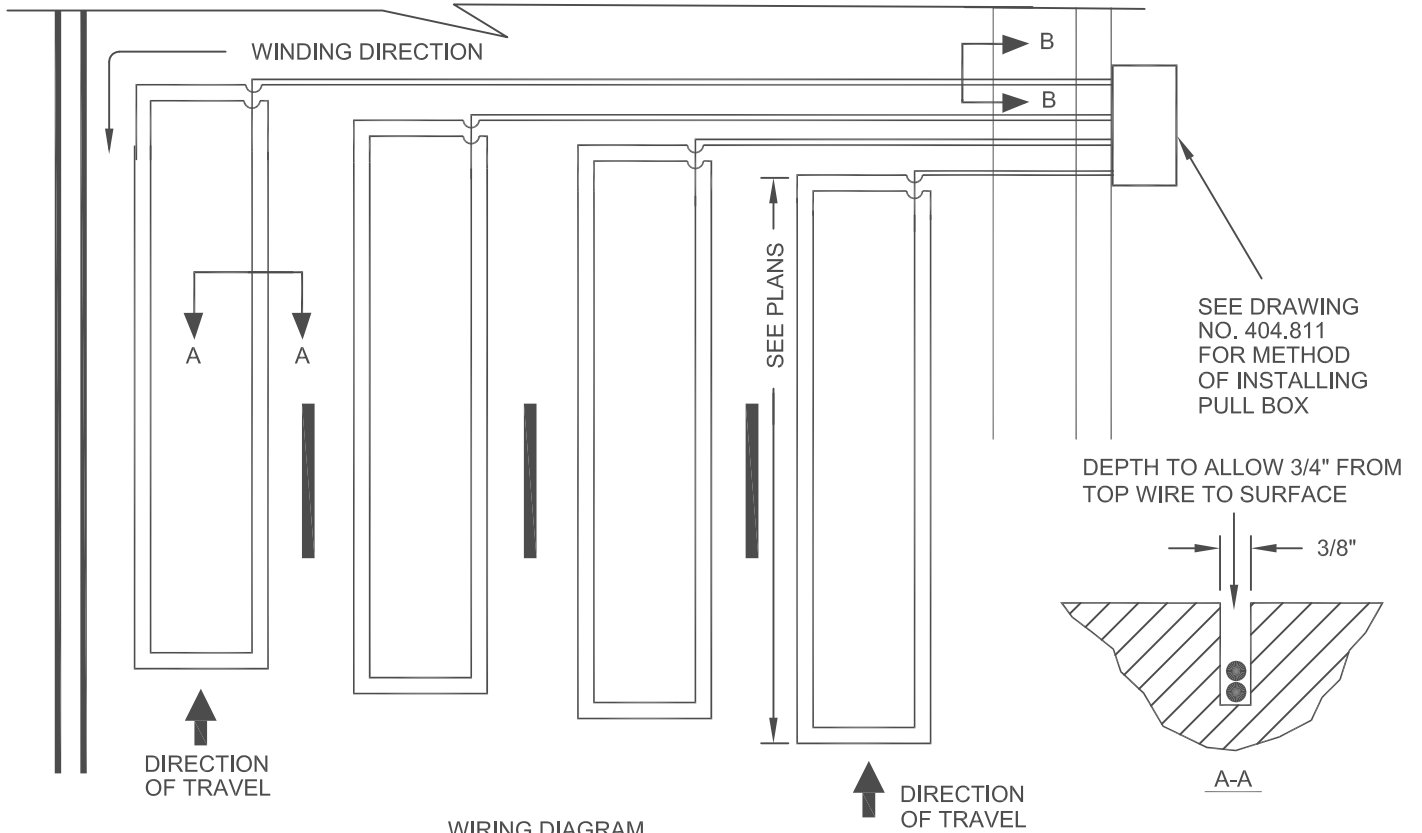

WIRING DIAGRAM

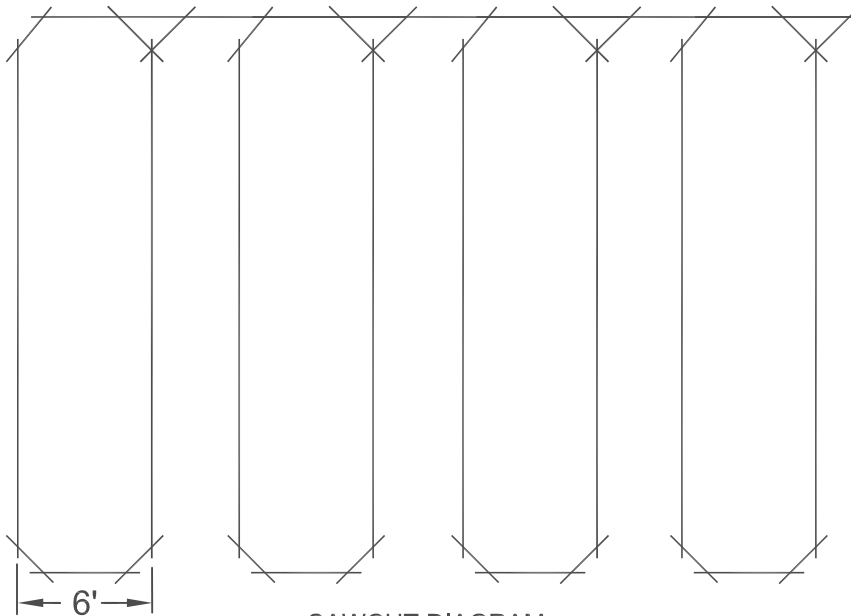

SAWCUT DIAGRAM

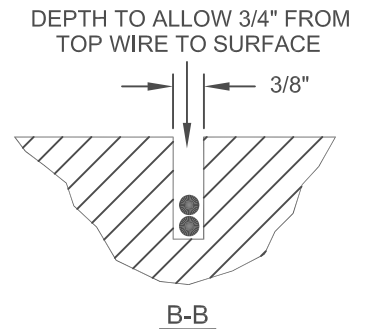

SEE DRAWING NO. 404.810 FOR SAWCUT DETAILS.

* PROFESSIONAL ELECTRICAL ENGINEER STAMP ON FILE.

SPECIFICATION REFERENCE

UNIFORM STANDARD DRAWINGS
CLARK COUNTY AREA

4 INDUCTION LOOPS
FOR 4 TRAVEL LANES

DATE

DWG. NO.

404.823

SHEET

2 OF 2

NOTES:

1. 4 TURNS OF WIRE SHOWN. ALWAYS INSTALL 4 TURNS OF CABLE IN DUCT UNLESS OTHERWISE SPECIFIED ON THE PLANS. WINDING DIRECTION SHALL BE INDICATED ON WIRE.
2. TRAFFIC ENGINEER SHALL ESTABLISH LATERAL LOCATIONS ON ROADS WITHOUT MARKED LANES.

SEE DRAWING NO. 404.811 FOR METHOD OF INSTALLING PULL BOX.

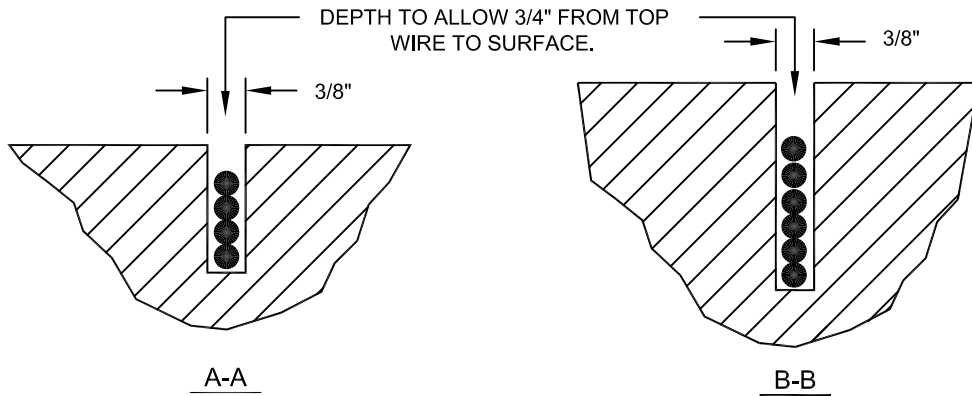
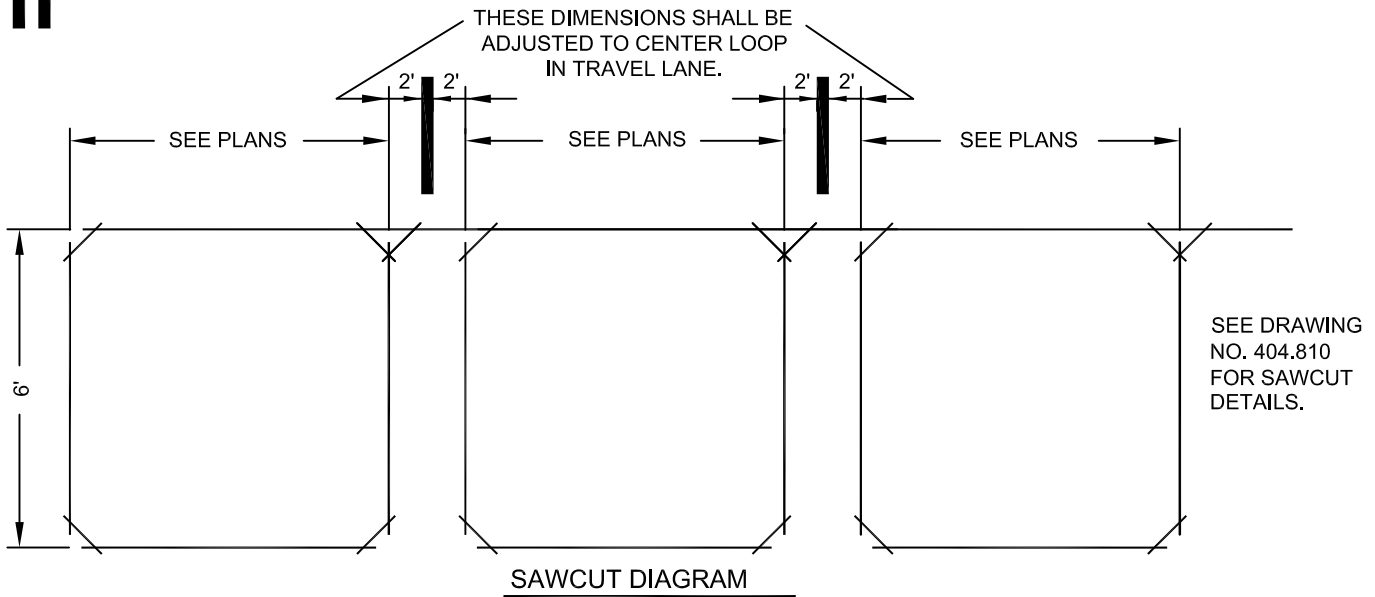
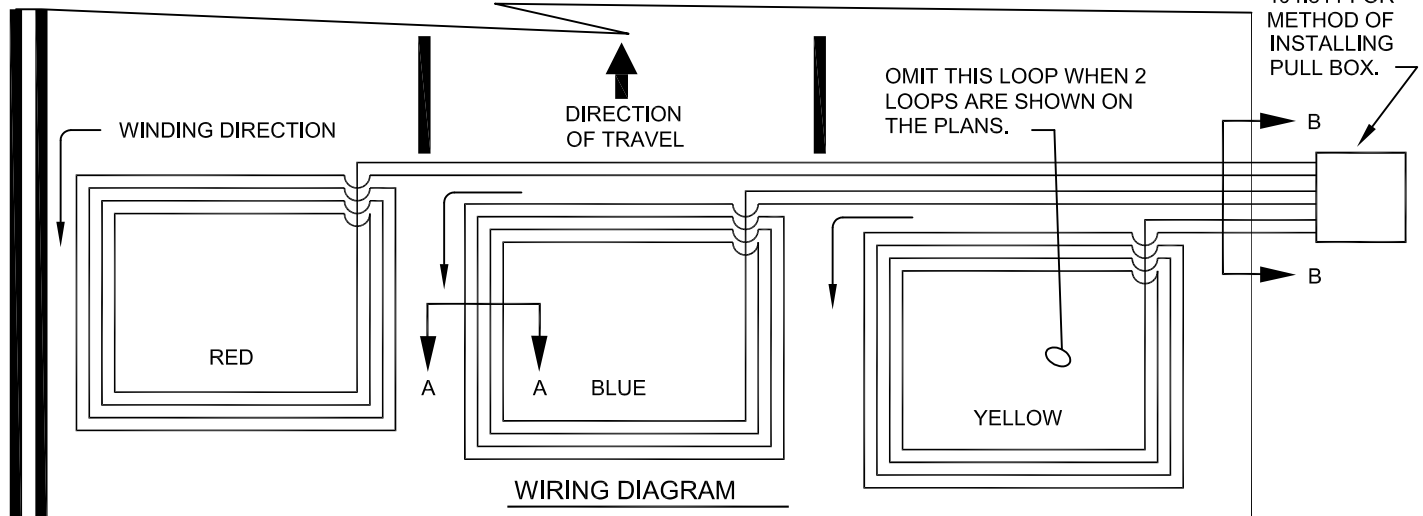

SPECIFICATION REFERENCE

UNIFORM STANDARD DRAWINGS
CLARK COUNTY AREA

3 INDUCTION LOOPS
FOR 3 TRAVEL LANES

DATE

DWG. NO.

404.825

SHEET

1 OF 1

NOTES:

1. FRONT OF THE LOOP MUST EXTEND INTO THE CROSSWALK 2' TO 4'.
2. INSULATION TEST FOR EACH LOOP TO GROUND MUST NOT READ LESS THAN 50 MEG OHMS TO INFINITY. (USING MEGGER)
3. USE COLOR CODED 4 TURN CABLE IN DUCT AS SHOWN.
4. SEE DRAWING NO. 404.829 FOR WIRING CONNECTIONS.

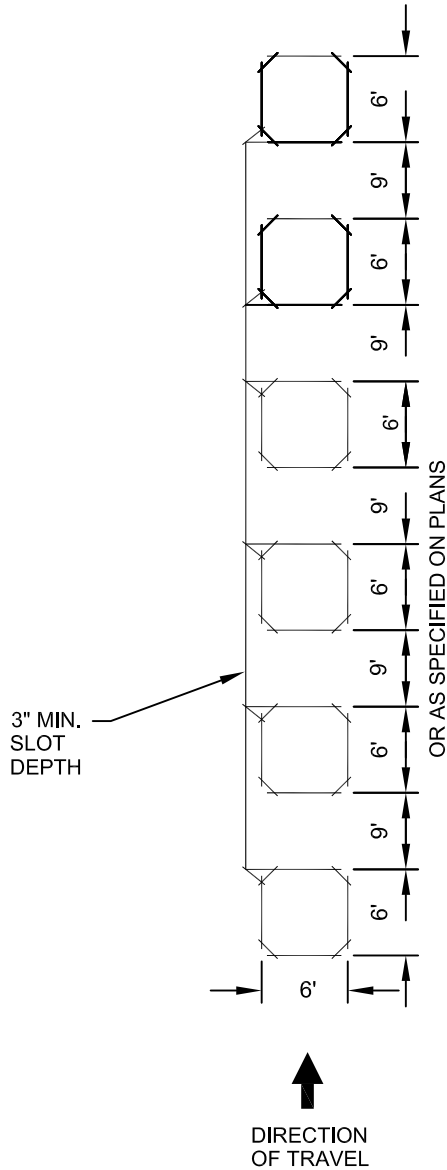

SEE DRAWING NO. 404.811 FOR METHOD OF INSTALLING PULL BOX ALL WIRES INTO PULL BOX MUST BE TAGGED AND WINDING DIRECTION SHALL BE MARKED.

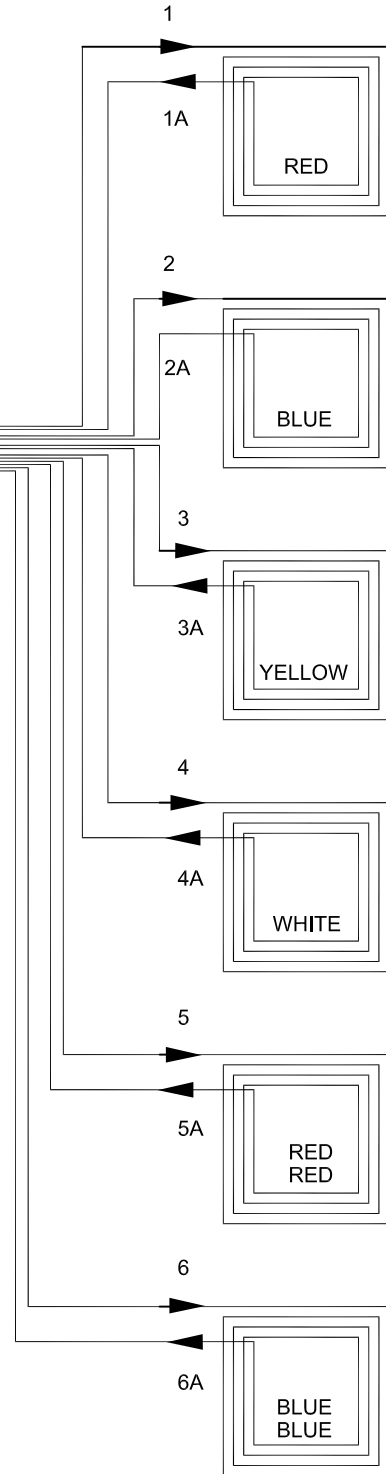

WIRING DIAGRAM

SEE DRAWING NO. 404.829 FOR WIRE CONNECTIONS.
SEE DRAWING NO. 404.810 FOR SAWCUT DETAILS.

SPECIFICATION REFERENCE

UNIFORM STANDARD DRAWINGS
CLARK COUNTY AREA

MULTIPLE LOOP SYSTEM FOR
THRU LANE

NOTES:

1. FRONT OF THE LOOP MUST EXTEND IN THE CROSSWALK 2' TO 4'.
2. INSULATION TEST FOR EACH LOOP TO GROUND MUST NOT READ LESS THAN 50 MEG OHMS TO INFINITY. (USING MEGGER)
3. USE COLOR CODED 4 TURN CABLE IN DUCT AS SHOWN.

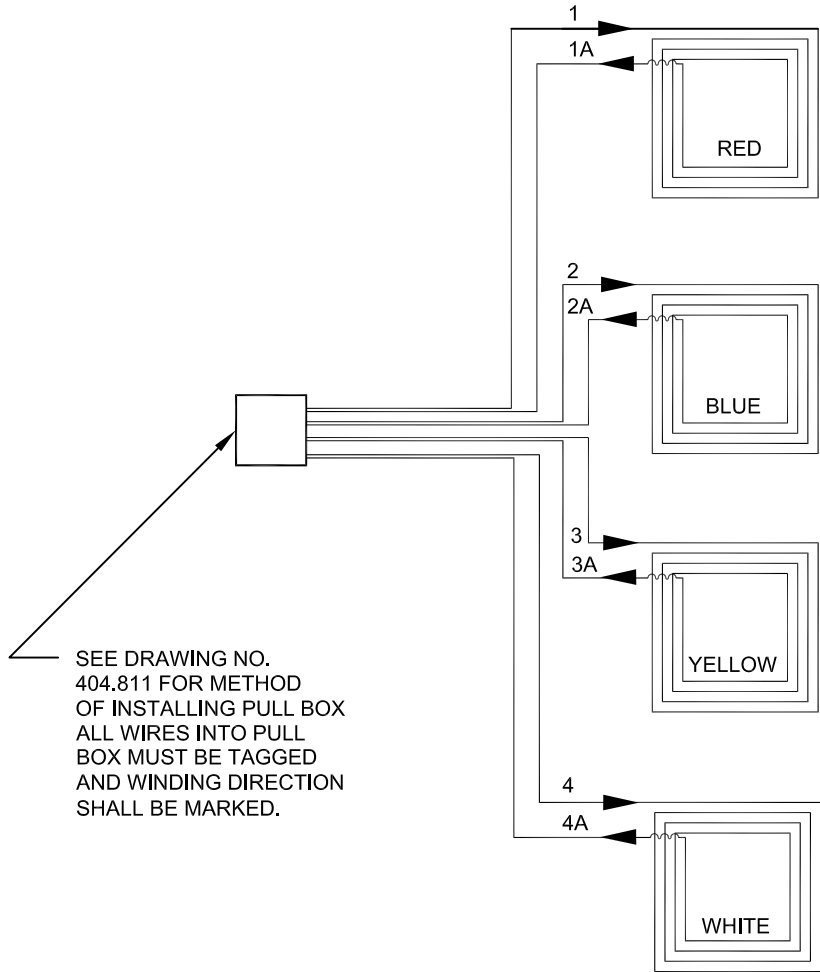
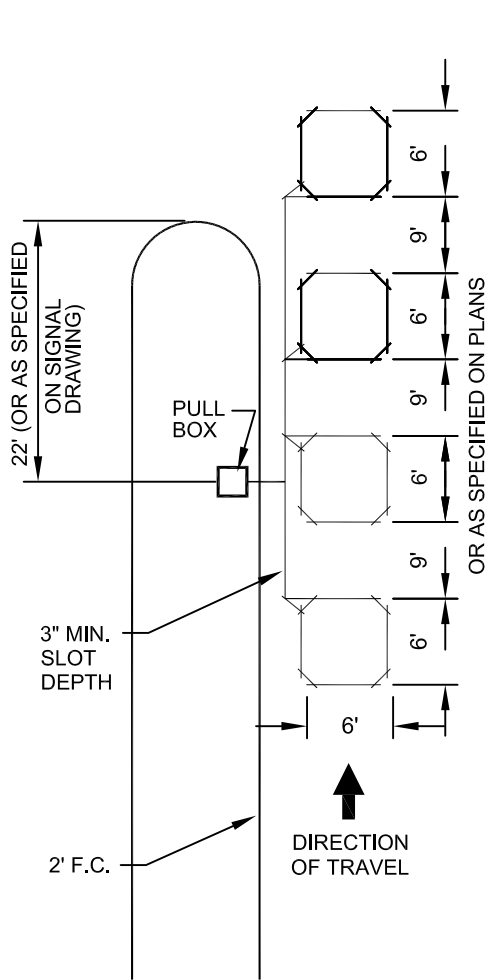

WIRING DIAGRAM

SEE DRAWING NO. 404.829 FOR WIRE CONNECTIONS.
SEE DRAWING NO. 404.810 FOR SAWCUT DETAILS.

SPECIFICATION REFERENCE

UNIFORM STANDARD DRAWINGS
CLARK COUNTY AREA

MUTIPLE LOOP SYSTEM FOR
LEFT TURN POCKET

TYPE "QUADRUPOLE" LOOP INSTALLATION

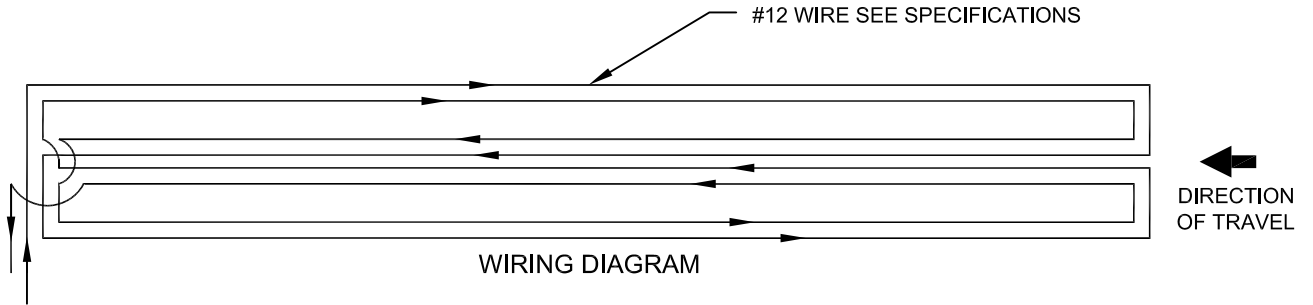

WHENEVER MORE THAN ONE LOOP TERMINATES IN A PULL BOX,
ALL LEADS MUST BE TAGGED AND IDENTIFIED.

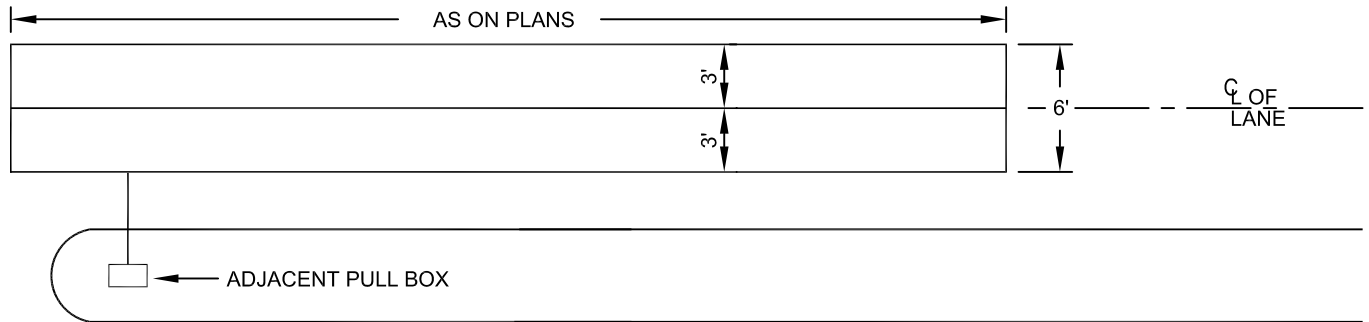

NOTES:

1. FOR ALL LOOPS, TWO TURNS ARE REQUIRED.
2. FRONT OF LOOP MUST EXTEND IN THE CROSSWALK 2' TO 4'.

SPECIFICATION REFERENCE

UNIFORM STANDARD DRAWINGS
CLARK COUNTY AREA

TYPE "QUADRUPOLE"
LOOP INSTALLATION

DATE	DWG. NO.	404.828	SHEET	1 OF 1
------	----------	---------	-------	--------

SEE DRAWING NO. 404.827 FOR LOOP LAYOUT

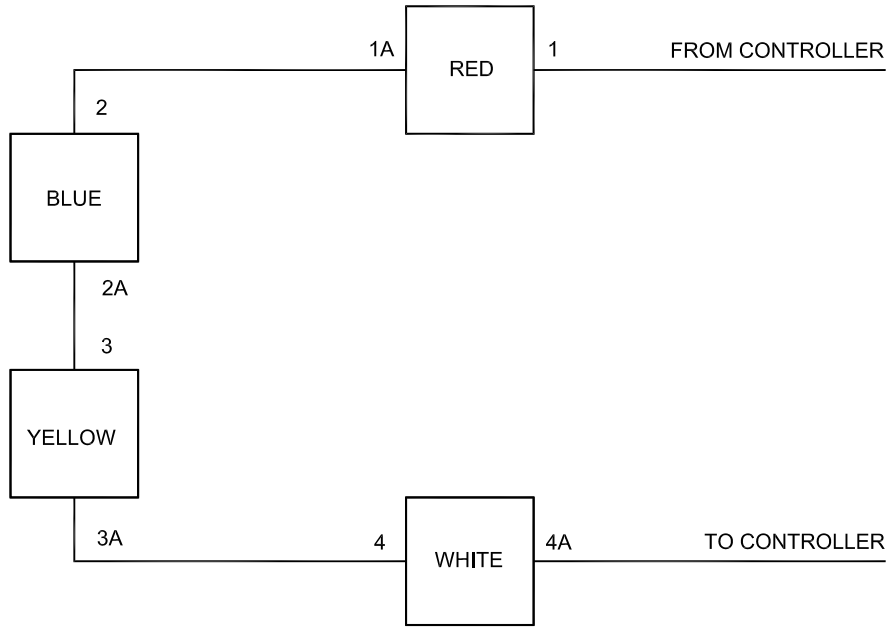

SEE DRAWING NO. 404.826 FOR LOOP LAYOUT

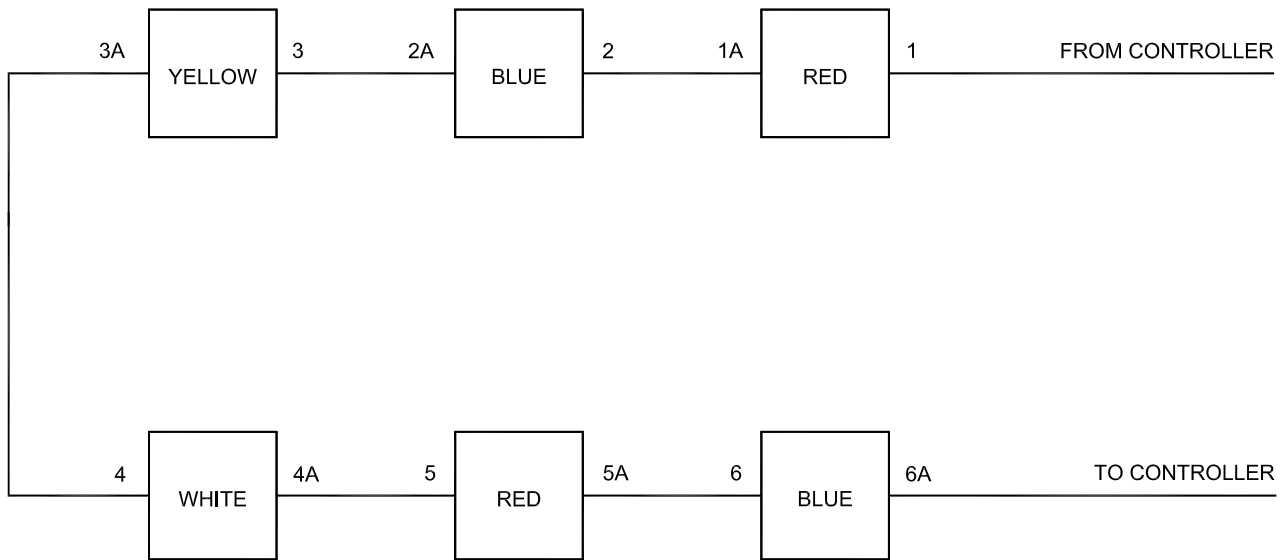

SPECIFICATION REFERENCE

UNIFORM STANDARD DRAWINGS
CLARK COUNTY AREA

WIRE DIAGRAMS FOR MULTIPLE
LOOP SYSTEMS FOR LEFT TURN
POCKET AND THRU LANE

DATE 12-12-96 DWG. NO. 404.829 SHEET 1 OF 1

NOTES:

1. INSULATION FOR EACH LOOP MUST NOT READ LESS THAN 50 MEG OHMS TO INFINITY. (USING MEGGER)
2. USE COLOR CODED 4 TURN CABLE IN DUCT AS SHOWN.
3. FRONT OF LOOP MUST EXTEND IN THE CROSSWALK 2' TO 4'.

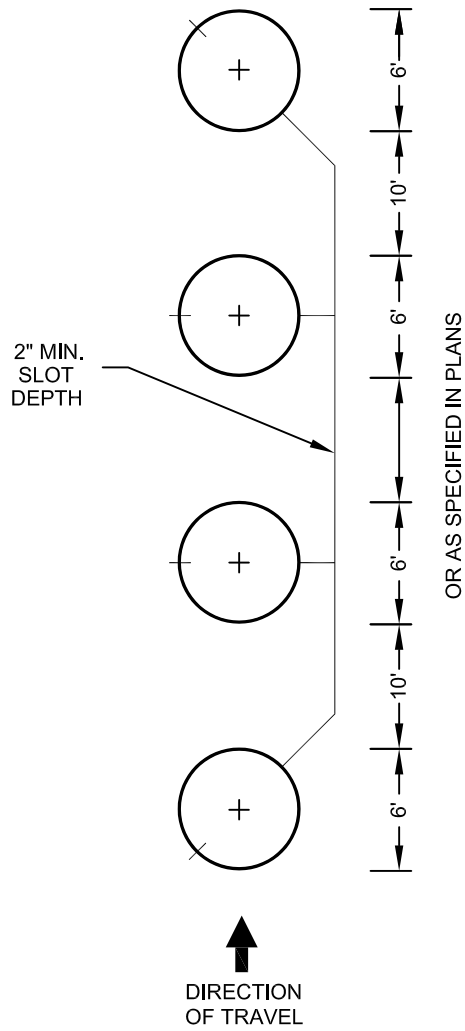

SAWCUT DIAGRAM

OR AS SPECIFIED IN PLANS

SEE DRAWING NO. 404.811 FOR METHOD OF INSTALLING PULL BOX ALL WIRES TO PULL BOX MUST BE TAGGED AND WINDING DIRECTION SHALL BE MARKED.

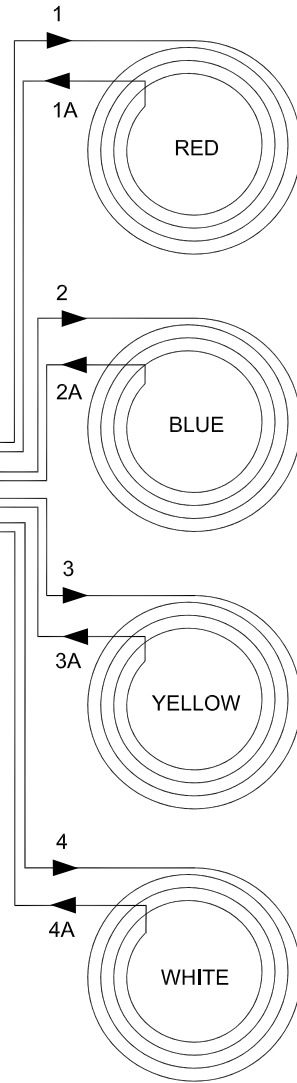

WIRING DIAGRAM

SPECIFICATION REFERENCE

UNIFORM STANDARD DRAWINGS
CLARK COUNTY AREA

CIRCULAR INDUCTION LOOPS
FOR TRAVEL LANES

DATE

DWG. NO.

404.830

SHEET

1 OF 1

MACHINE OFF CAP FOR
8'-6" PEDESTRIAN
PUSH BUTTON POST

DIA. TO FIT
STANDARD

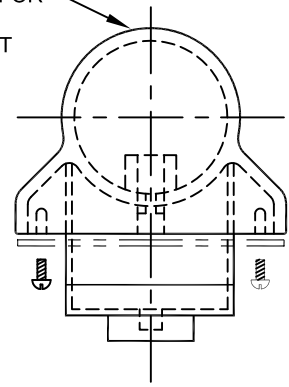
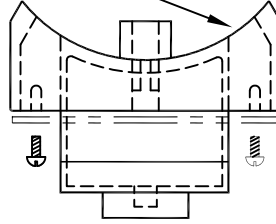
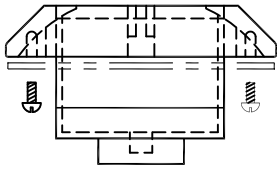

NOTES:

1. CAST ALUMINUM HOUSING.
2. PAINT COLOR SHALL MATCH SIGNAL HOUSING.

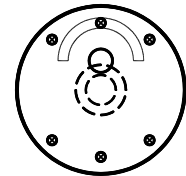
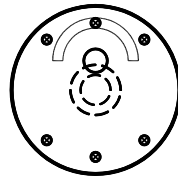
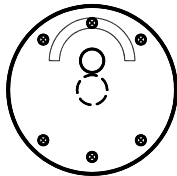
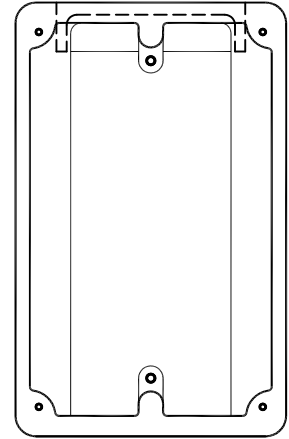
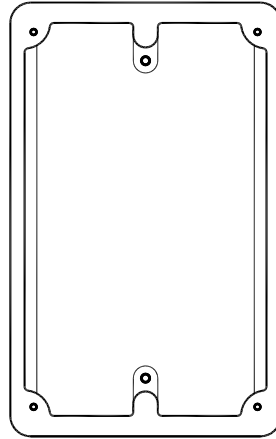
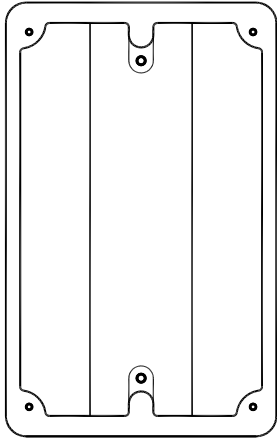

FOR FLAT SURFACE
MOUNTING

FOR SIGNAL
STANDARD MOUNTING

FOR 2-1/2" IPS
MOUNTING

NOTES:

1. AT LOCATIONS WHERE "WALK" "DON'T WALK" SIGNALS ARE PROVIDED, PROVIDE BLACK LETTERING ON A WHITE BACKGROUND ON PORCELAIN SIGNS.
2. AT LOCATIONS WHERE "SYMBOLIC" SIGNALS ARE PROVIDED, PROVIDE WHITE FIGURES ON A BLACK BACKGROUND.
3. MOUNTING SURFACE FOR THE SIGNS SHALL BE 9" X 12".

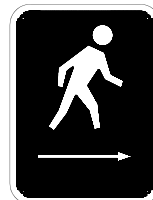
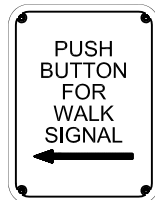

SPECIFICATION REFERENCE

UNIFORM STANDARD DRAWINGS
CLARK COUNTY AREA

PEDESTRIAN PUSH BUTTON
DETECTORS

DATE	DWG. NO.	404.851	SHEET	1 OF 1
------	----------	---------	-------	--------

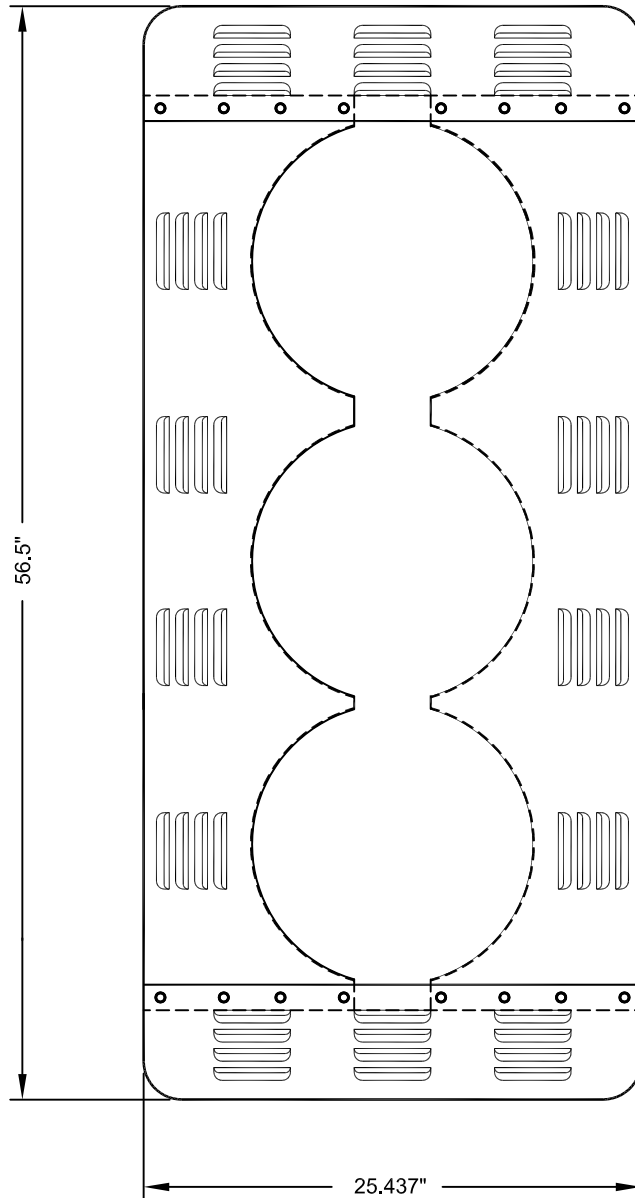

PAINT: FLAT BLACK
 SHOWN 3 SECTION, 12" SIGNAL HEAD WITH ELEVATOR PLUMBIZER

SPECIFICATION REFERENCE

UNIFORM STANDARD DRAWINGS
 CLARK COUNTY AREA

LOUVERED BACKPLATE FOR
 MAST ARM MOUNTED SIGNAL

DATE	DWG. NO.	404.900	SHEET	1 OF 1
------	----------	---------	-------	--------

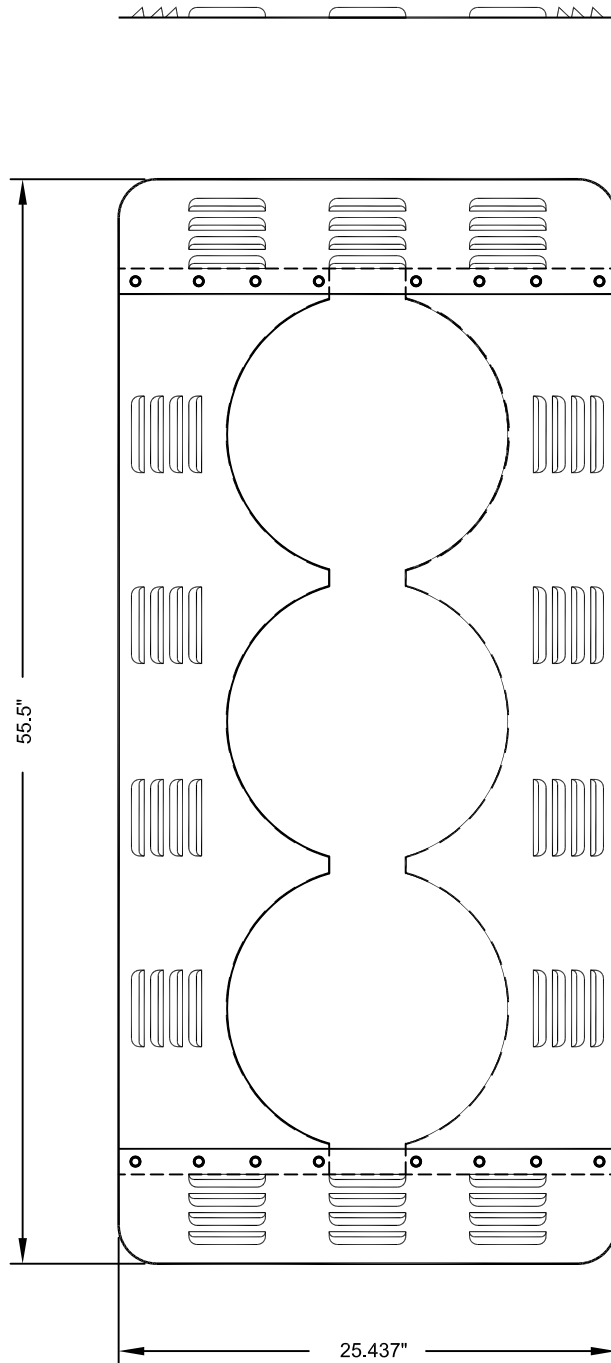

PAINT: FLAT BLACK
 SHOWN 3 SECTION, 12" SIGNAL HEAD BACKPLATE WITHOUT ELEVATOR PLUMBIZER

SPECIFICATION REFERENCE

UNIFORM STANDARD DRAWINGS
 CLARK COUNTY AREA

LOUVERED BACKPLATE FOR
 POLE MOUNTED SIGNAL

DATE	DWG. NO.	404.901	SHEET	1 OF 1
------	----------	---------	-------	--------

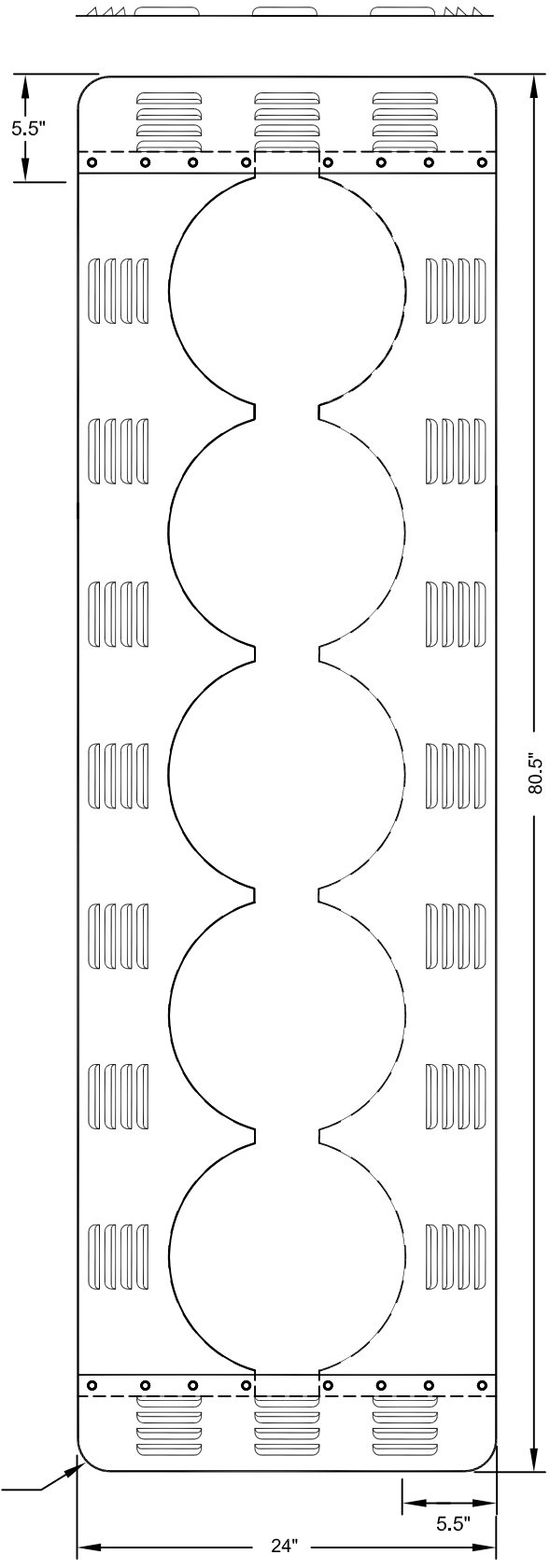

PAINT: FLAT BLACK
 SHOWN 5 SECTION, 12" SIGNAL
 HEAD BACKPLATE WITHOUT
 ELEVATOR PLUMBIZER

Effective 01/01/09 - 06/30/09

SPECIFICATION REFERENCE		UNIFORM STANDARD DRAWINGS CLARK COUNTY AREA		
		LOUVERED BACKPLATE FOR 5 SECTION SIGNAL HEAD		
DATE	DWG. NO.	404.902	SHEET	1 OF 1

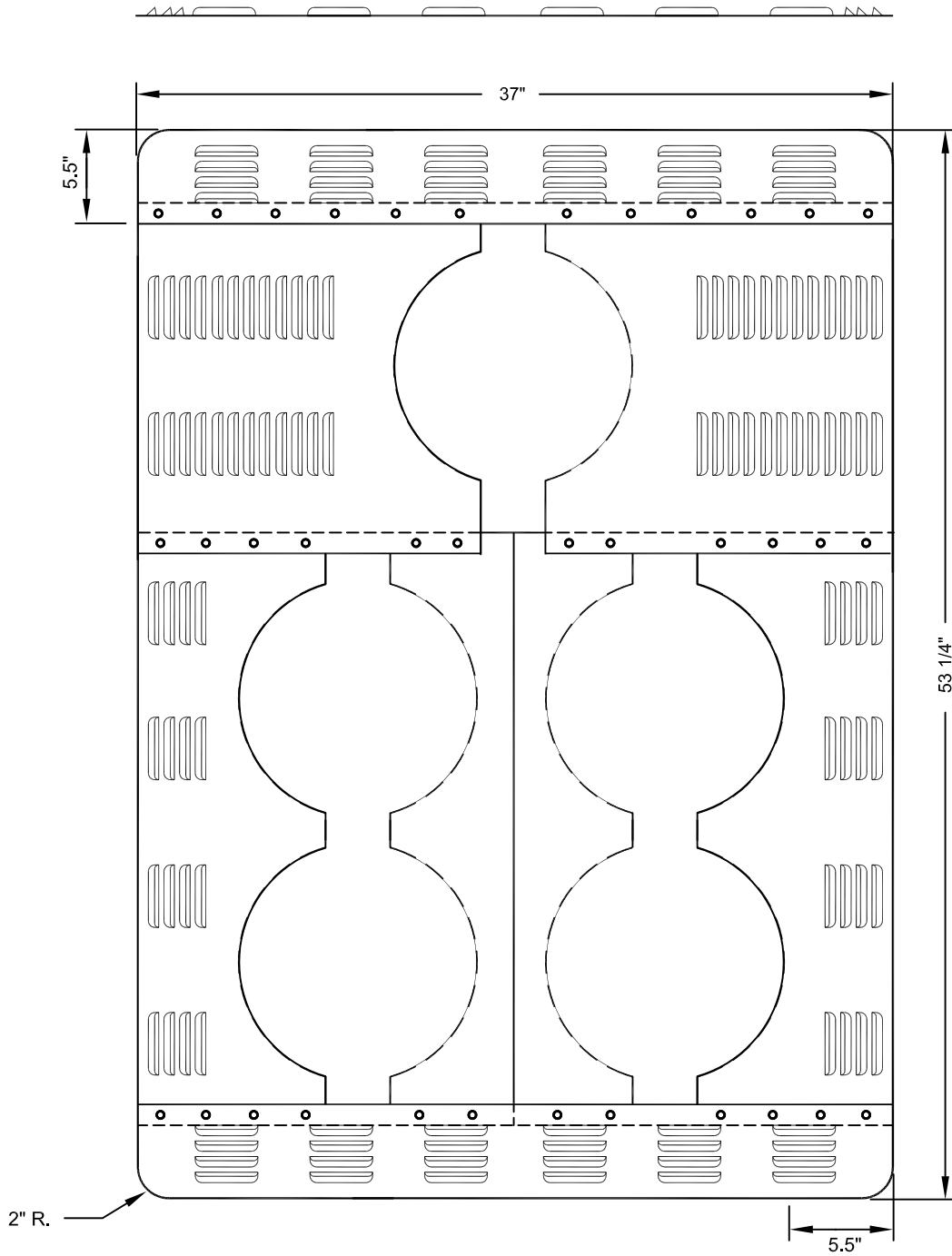

PAINT: FLAT BLACK

SHOWN 5 SECTION, 12" SIGNAL
HEAD BACKPLATE WITH
ELEVATOR PLUMBIZER

REFER TO DRAWING NO. 404.1029

Effective 01/01/09 - 06/30/09

SPECIFICATION REFERENCE		UNIFORM STANDARD DRAWINGS CLARK COUNTY AREA		
		LOUVERED BACKPLATE FOR 5 SECTION SIGNAL HEAD		
		DATE	DWG. NO. 404.903	SHEET 1 OF 1

ITEM	DESCRIPTION	STANDARD DWG. NO.
1.	DOGLEG	404.1029
2.	ELEVATOR PLUMBIZER	404.1203
3.	POLE PLATE WITH WIRE GUIDE	404.1204
4.	2-WAY TIE BRACE	404.1200
5.	3-WAY TIE BRACE	404.1200
6.	4-WAY TIE BRACE	404.1200
7.	SPECIAL ELBOW	404.1202
8.	SPECIAL TEE	404.1202
9.	MALLEABLE ELBOW-REAMED/SET SCREW	404.1206
10.	MALLEABLE ELBOW/SIDE OUTLET/REAMED/SET SCREW	404.1206
11.	MALLEABLE TEE, REAMED/SET SCREW	404.1206
12.	MALLEABLE TEE/SIDE OUTLET, REAMED/SET SCREW	404.1206
13.	MALLEABLE CROSS, REAMED/SET SCREW	404.1206
14.	MALLEABLE CROSS/SIDE OUTLET, REAMED/SET SCREW	404.1206
15.	4-WAY CENTER HUB	404.1205
16.	POST TOP MOUNTED BRACKET	404.1202
17.	SIDE BRACKET MOUNTED ADAPTER WITH TERMINAL COMPT.	404.1208
18.	POST TOP MOUNTED ADAPTER WITH TERMINAL COMPT.	404.1207
19.	LOCKING RING	404.1200
20.	ORNAMENTAL CAP	404.1200
21.	POST TOP MOUNTED ADAPTER WITH 3 PORTS	404.1208
22.	LOCKING NIPPLE	404.1200
23.	POLE PLATE	404.1201
24.	1-1/2" MENERALLAC STRAP OR APPROVED EQUAL	404.1029

SPECIFICATION REFERENCE

UNIFORM STANDARD DRAWINGS
CLARK COUNTY AREA

BILL OF MATERIALS
SIGNAL ASSEMBLIES

DATE : 10-9-08

DWG. NO. 404.1005

SHEET 1 OF 1

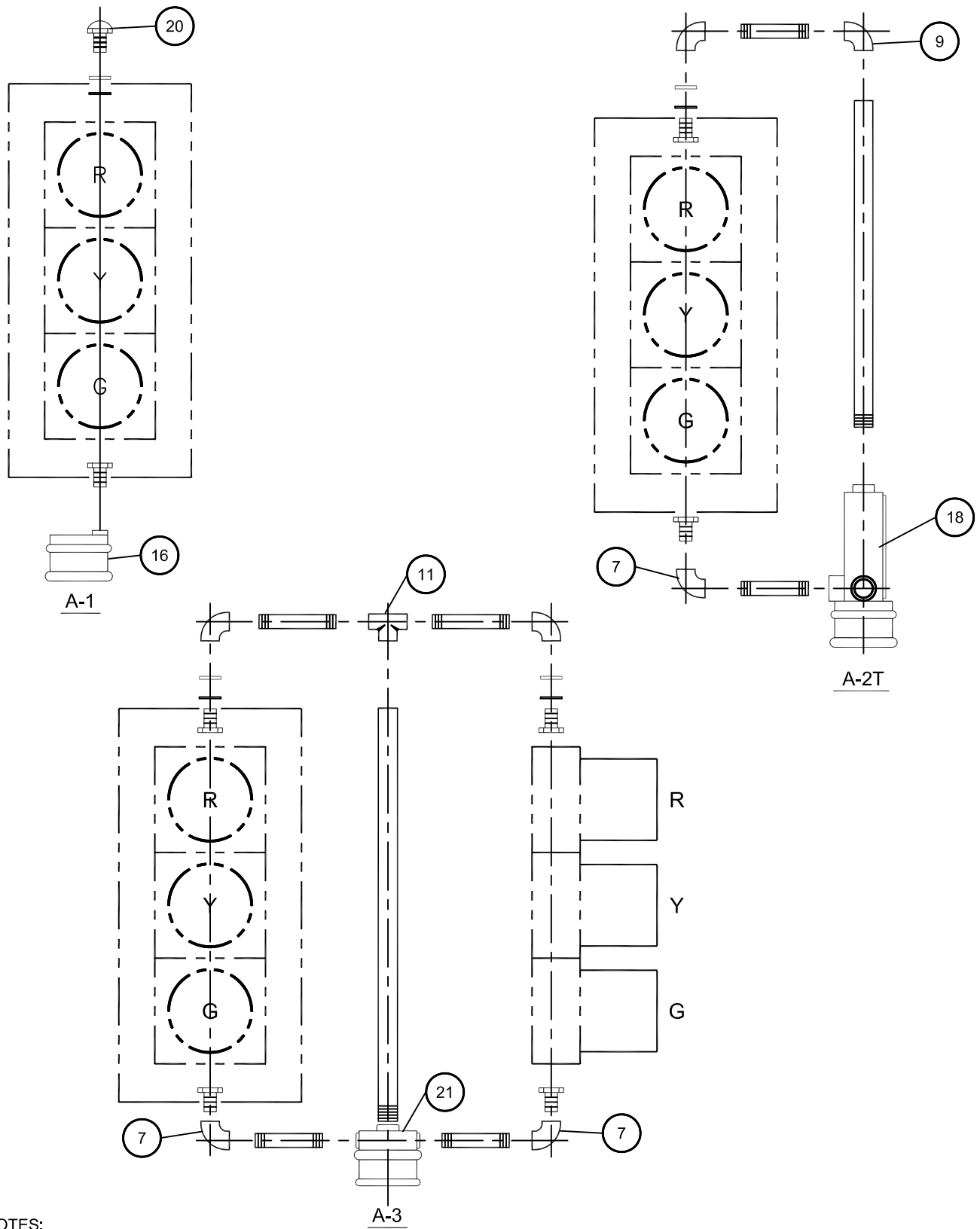

NOTES:

- 1. ALL SIGNALS ARE 12" NOMINAL (GLASS).
- 2. FOR ITEMIZED PARTS, SEE DRAWING NO. 404.1005.

Effective 01/01/09 - 06/30/09

SPECIFICATION REFERENCE	UNIFORM STANDARD DRAWINGS CLARK COUNTY AREA		
	SIGNAL ASSEMBLIES A-1, A-2T, A-3		
DATE	DWG. NO.	404.1011	SHEET 1 OF 1

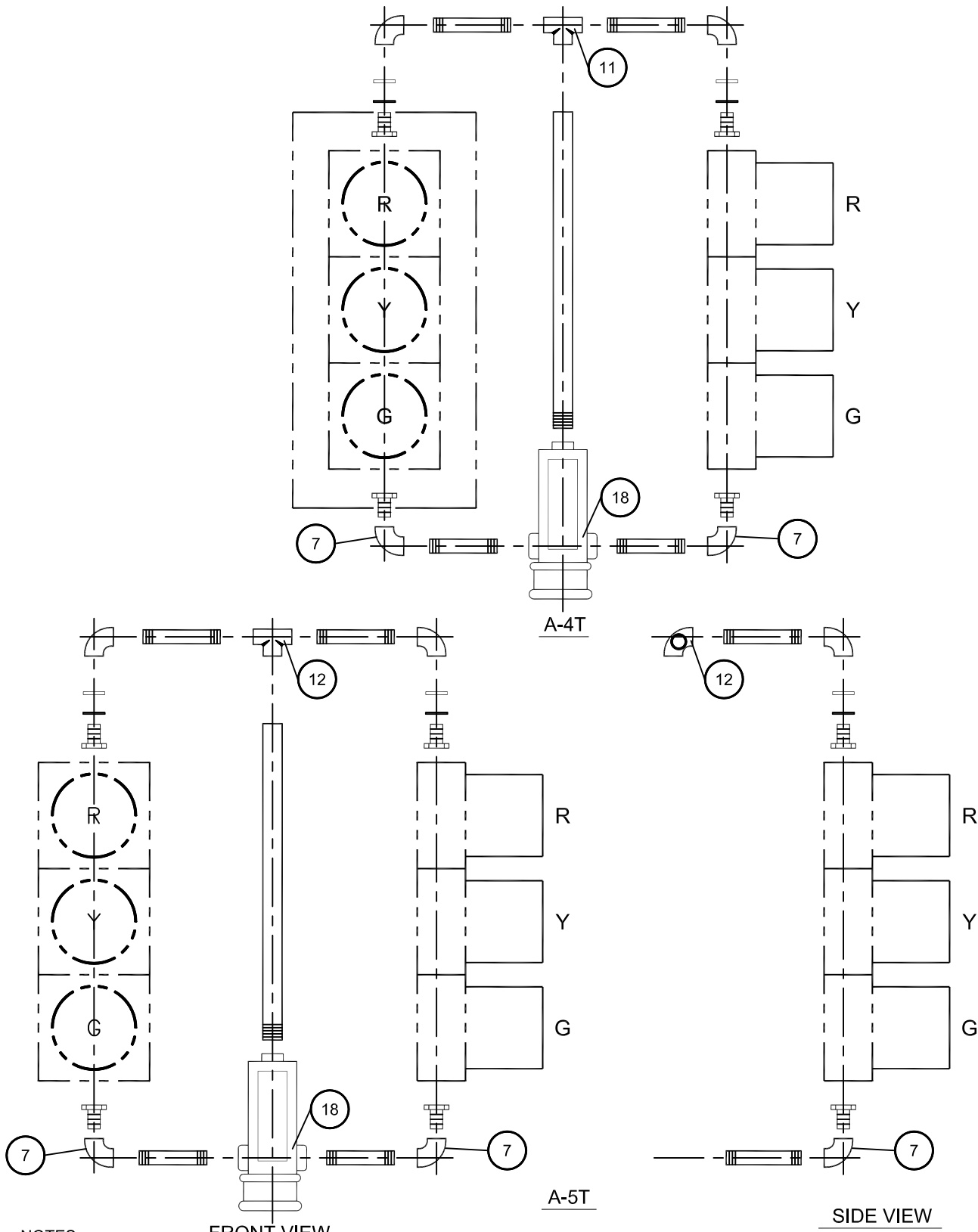

NOTES:

- 1. ALL SIGNALS ARE 12" NOMINAL (GLASS).
- 2. FOR ITEMIZED PARTS, SEE DRAWING NO. 404.1005.

FRONT VIEW

SIDE VIEW

SPECIFICATION REFERENCE		UNIFORM STANDARD DRAWINGS CLARK COUNTY AREA		
		SIGNAL ASSEMBLIES A-4T, A-5T		
DATE	DWG. NO.	404.1012	SHEET	1 OF 1

Effective 01/01/09 - 06/30/09

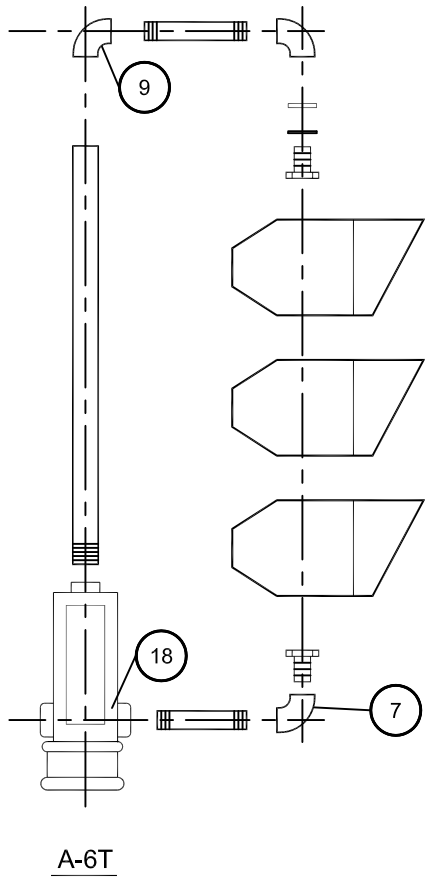

R
OR
RED ARROW

YELLOW ARROW

GREEN ARROW

PROGRAMMED
VISIBILITY
HEAD

A-6T

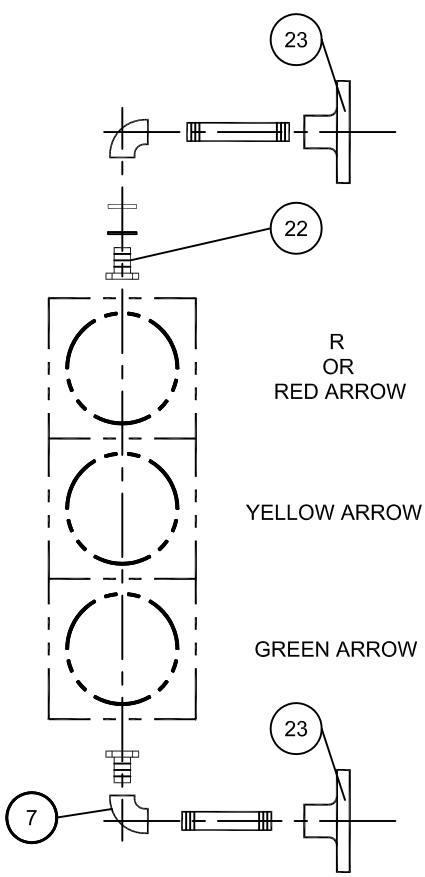

R
OR
RED ARROW

YELLOW ARROW

GREEN ARROW

NOTES:

1. ON LOWER ASSEMBLY, ALL INDICATIONS ARE 12" NOMINAL (GLASS).
2. SEE DRAWING NO. 404.1410 FOR ARROW LENS.
3. ON TOP ASSEMBLY, USE M-3 WITH BACKPLATE.
4. SEE STANDARD SPECIFICATIONS FOR PROGRAMMED VISIBILITY HEAD.
5. SEE DRAWING NO. 404.1005 FOR ITEMIZED PARTS.
6. SEE SIGNAL PLANS FOR R OR RED ARROW INDICATION.

Effective 01/01/09 - 06/30/09

SPECIFICATION REFERENCE		UNIFORM STANDARD DRAWINGS CLARK COUNTY AREA			
		SIGNAL ASSEMBLIES A-6T			
DATE	2-11-93	DWG. NO.	404.1013	SHEET	1 OF 1

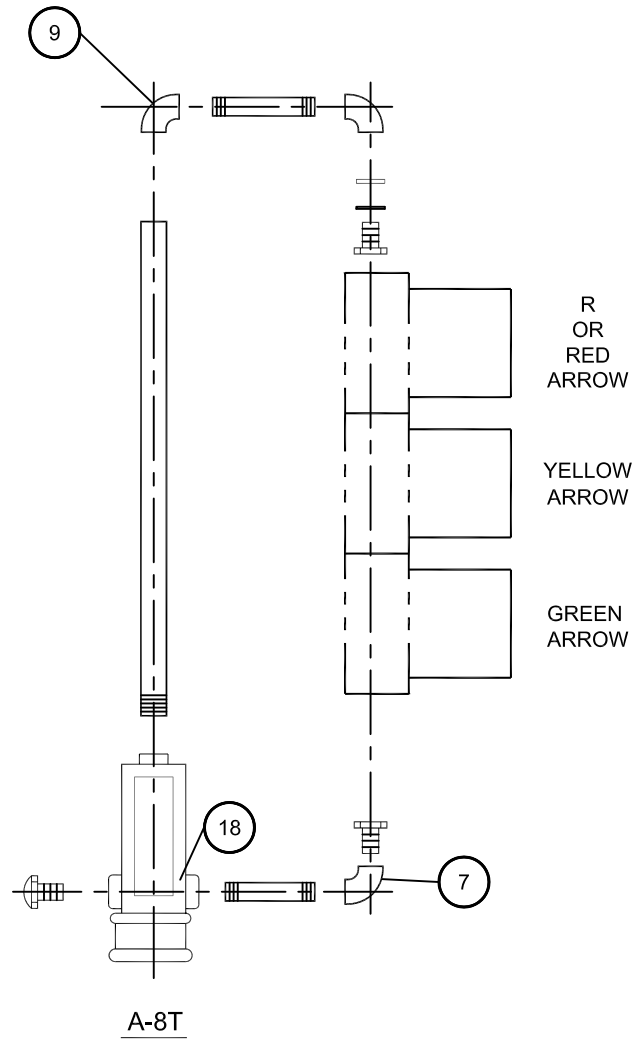
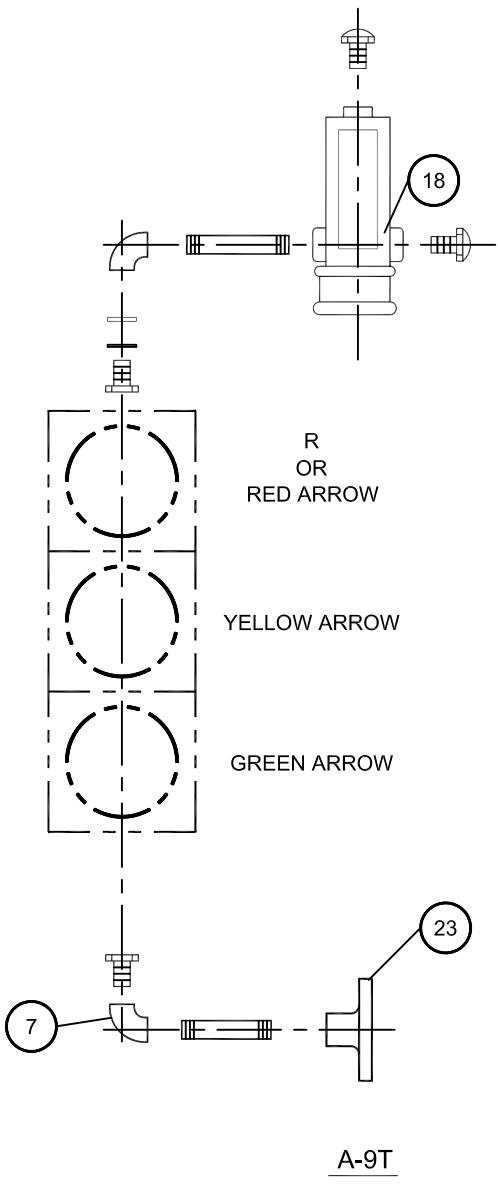

NOTES:

1. PROVIDE BACKPLATE ON A-8T.
2. ALL INDICATIONS ARE 12" NOMINAL (GLASS).
3. SEE DRAWING NO. 404.1410 OR ARROW LENS.
4. SEE DRAWING NO. 404.1005 FOR ITEMIZED PARTS.
5. SEE SIGNAL PLANS FOR R OR RED ARROW INDICATION.

Effective 01/01/09 - 06/30/09

SPECIFICATION REFERENCE		UNIFORM STANDARD DRAWINGS CLARK COUNTY AREA		
		SIGNAL ASSEMBLIES A-8T, A-9T		
DATE	2-11-93	DWG. NO.	404.1015	SHEET 1 OF 1

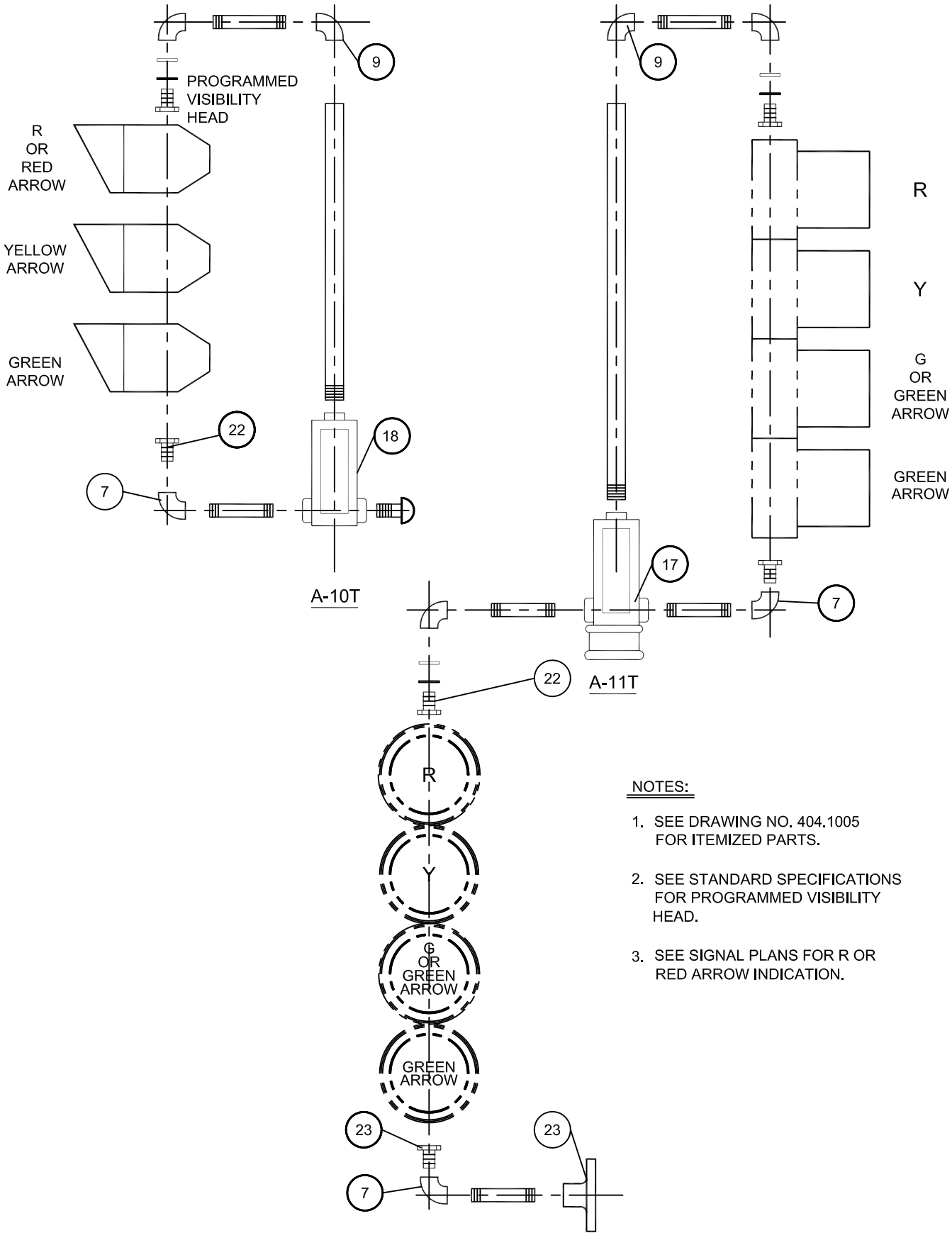

SPECIFICATION REFERENCE

UNIFORM STANDARD DRAWINGS
CLARK COUNTY AREA

SIGNAL ASSEMBLIES
A-10T, A-11T

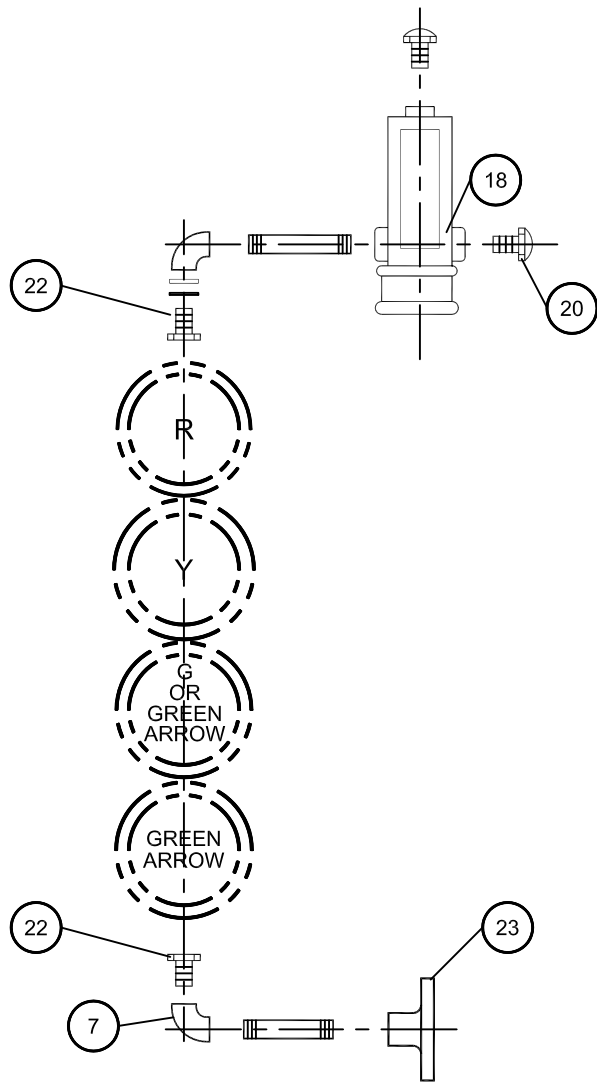

A-12T

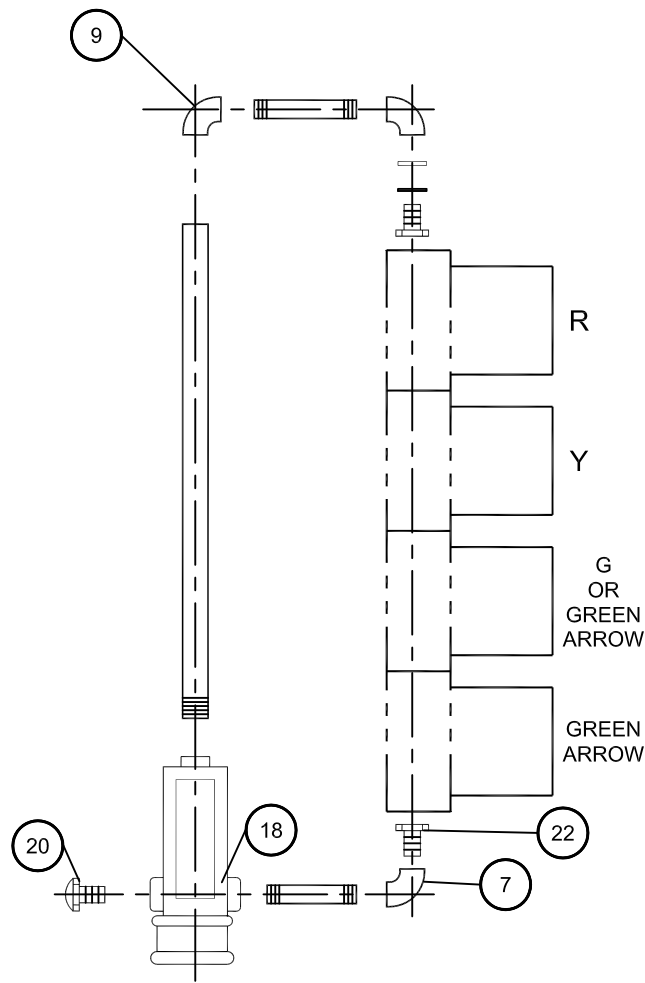

A-13T

NOTES:

1. FOR ITEMIZED PARTS SEE DRAWING NO. 404.1005.
2. FOR ARROW LENS SEE DRAWING NO. 404.1410.
3. PROVIDE BACKPLATE ON A-13T ONLY.
4. ALL SIGNALS ARE 12" NOMINAL (GLASS).

SPECIFICATION REFERENCE

UNIFORM STANDARD DRAWINGS
CLARK COUNTY AREA

SIGNAL ASSEMBLIES
A-12T, A-13T

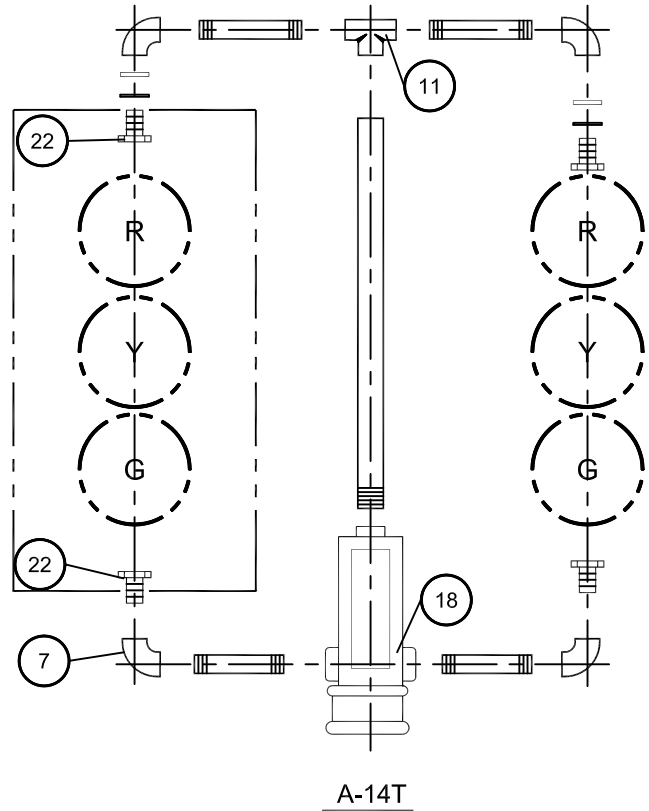
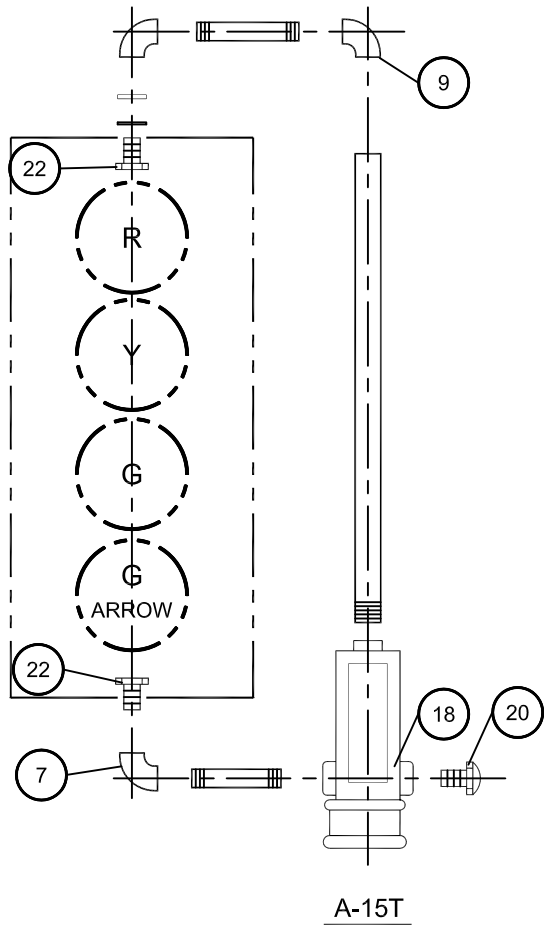

NOTES:

1. ALL SIGNALS ARE 12" NOMINAL (GLASS).
2. FOR ITEMIZED PARTS, SEE DRAWING NO. 404.1005.
3. FOR ARROW LENS SEE DRAWING NO. 404.1410.
4. SEE PLANS FOR BACKPLATE REQUIREMENTS.

SPECIFICATION REFERENCE

UNIFORM STANDARD DRAWINGS
CLARK COUNTY AREA

SIGNAL ASSEMBLIES
A-14T, A-15T

DATE	DWG. NO. 404.1018	SHEET	1 OF 1
------	-------------------	-------	--------

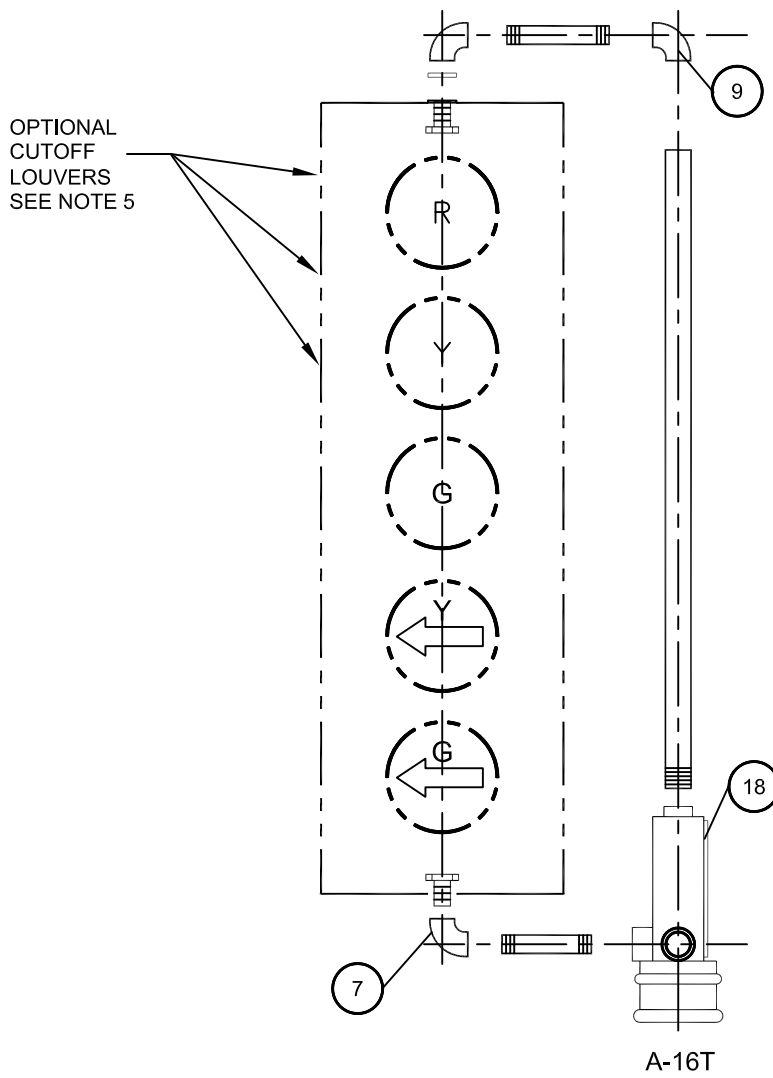

NOTES:

1. ALL SIGNALS ARE 12" NOMINAL (GLASS).
2. FOR ITEMIZED PARTS SEE DRAWING NO. 404.1005.
3. FOR ARROW LENS SEE DRAWING NO. 404.1410.
4. SEE PLANS FOR BACKPLATE REQUIREMENTS.
5. OPTIONAL 3° CUTOFF LOUVERS ON RED, YELLOW AND GREEN BALL INDICATIONS MAY BE PROVIDED AS DIRECTED BY THE TRAFFIC ENGINEER.

SPECIFICATION REFERENCE

UNIFORM STANDARD DRAWINGS
CLARK COUNTY AREA

SIGNAL ASSEMBLIES
A-16T

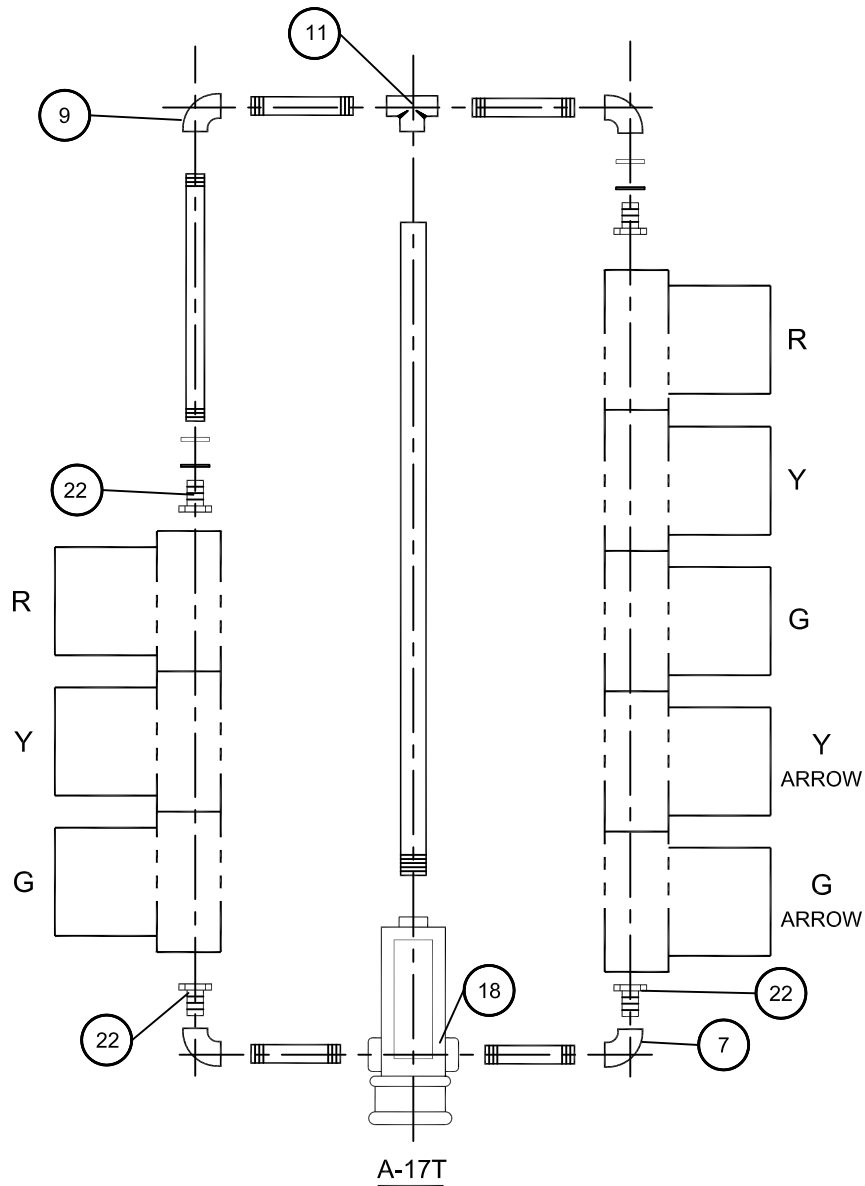

NOTES:

1. FOR ITEMIZED PARTS SEE DRAWING NO. 404.1005.
2. FOR ARROW LENS SEE DRAWING NO. 404.1410.
3. SEE PLANS FOR BACKPLATE REQUIREMENTS.
4. ALL SIGNALS ARE 12" NOMINAL (GLASS).

SPECIFICATION REFERENCE

UNIFORM STANDARD DRAWINGS
CLARK COUNTY AREA

SIGNAL ASSEMBLIES
A-17T

DATE	DWG. NO.	404.1020	SHEET	1 OF 1
------	----------	----------	-------	--------

PROVIDE LOUVERED BACKPLATE
SIMILAR TO DRAWING 404.900

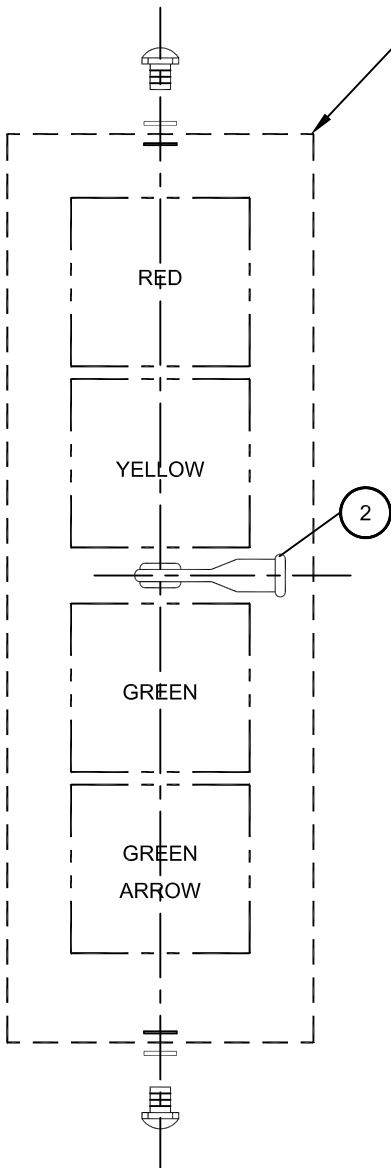

PROGRAMMED VISIBILITY HEADS
M-3A

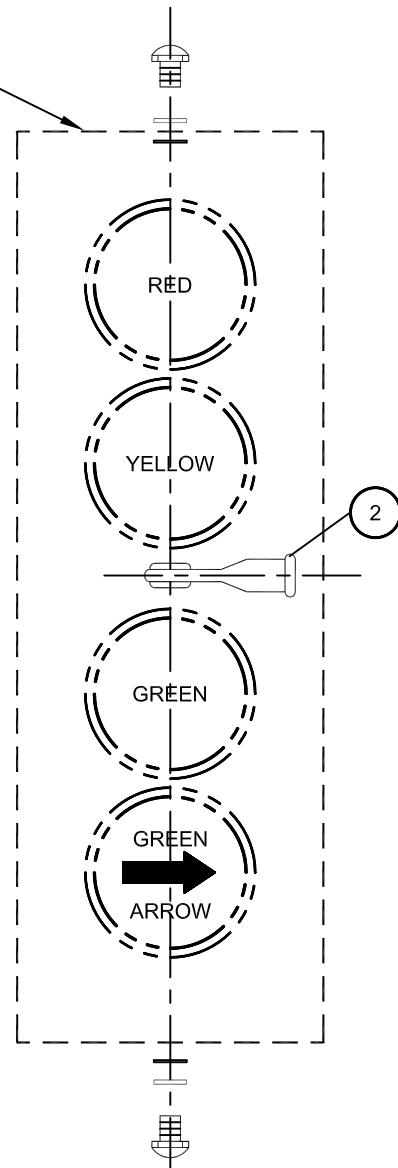

STANDARD 12" SIGNAL HEADS
M-2A

NOTES:

1. ALL SIGNALS ARE 12" NOMINAL (GLASS)
2. FOR ITEMIZED PARTS, SEE DRAWING 404.1005.

SPECIFICATION REFERENCE

UNIFORM STANDARD DRAWINGS
CLARK COUNTY AREA

MAST ARM SIGNAL ASSEMBLIES
M-2A, M-3A

DATE

DWG. NO.

404.1022

SHEET

1 OF 1

PROVIDE LOUVERED BACKPLATE
SIMILAR TO DRAWING 404.900

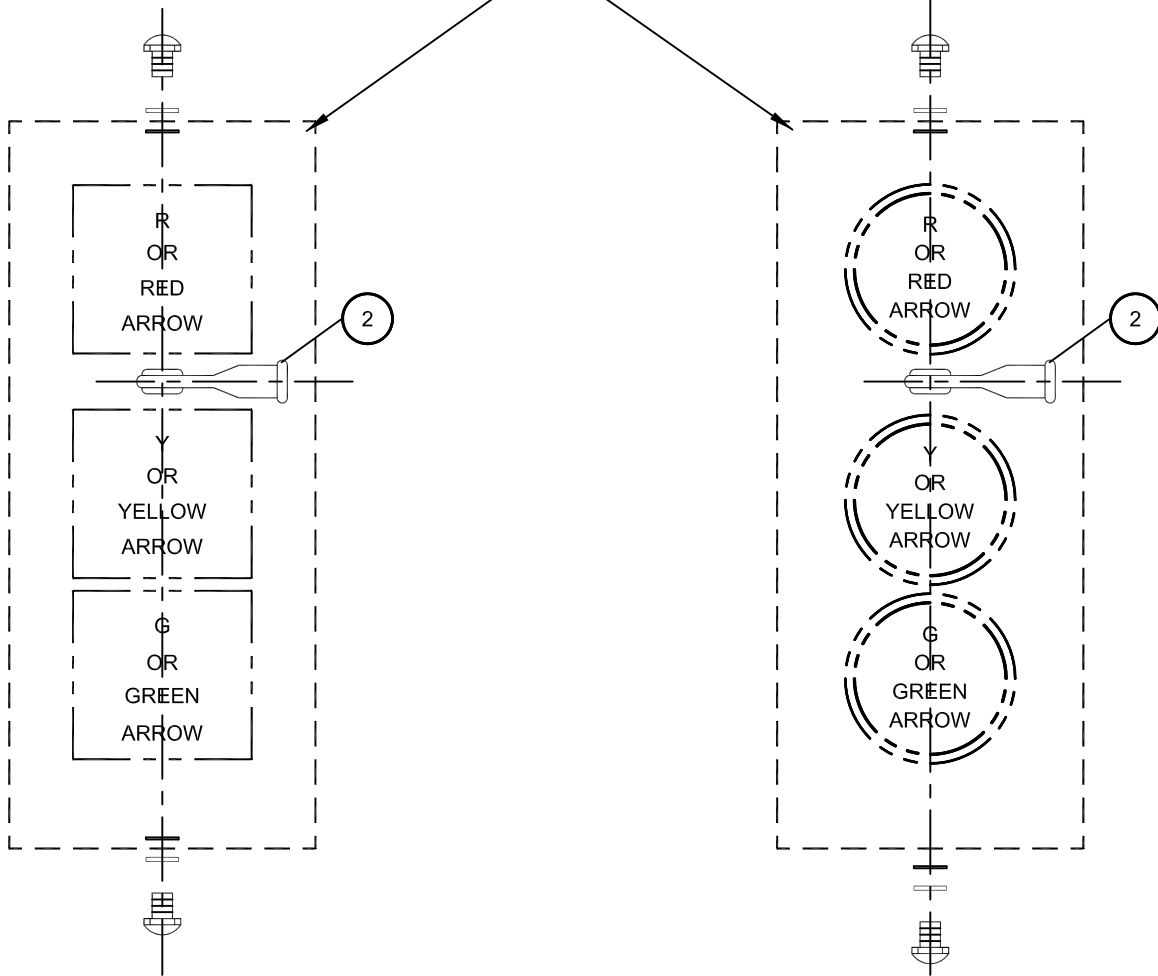

PROGRAMMED VISIBILITY HEADS
M-3

STANDARD 12" SIGNAL HEADS
M-2

NOTES:

1. SEE STANDARD SPECIFICATIONS FOR PROGRAMMED VISIBILITY HEAD.
2. ALL M-2 INDICATIONS ARE 12" NOMINAL (GLASS).
3. SEE DRAWING NO. 404.1005 FOR ITEMIZED PARTS.
4. SEE SIGNAL PLANS FOR BALL OR ARROW INDICATIONS.

SPECIFICATION REFERENCE

UNIFORM STANDARD DRAWINGS
CLARK COUNTY AREA

MAST ARM SIGNAL ASSEMBLIES
M-3, M-2

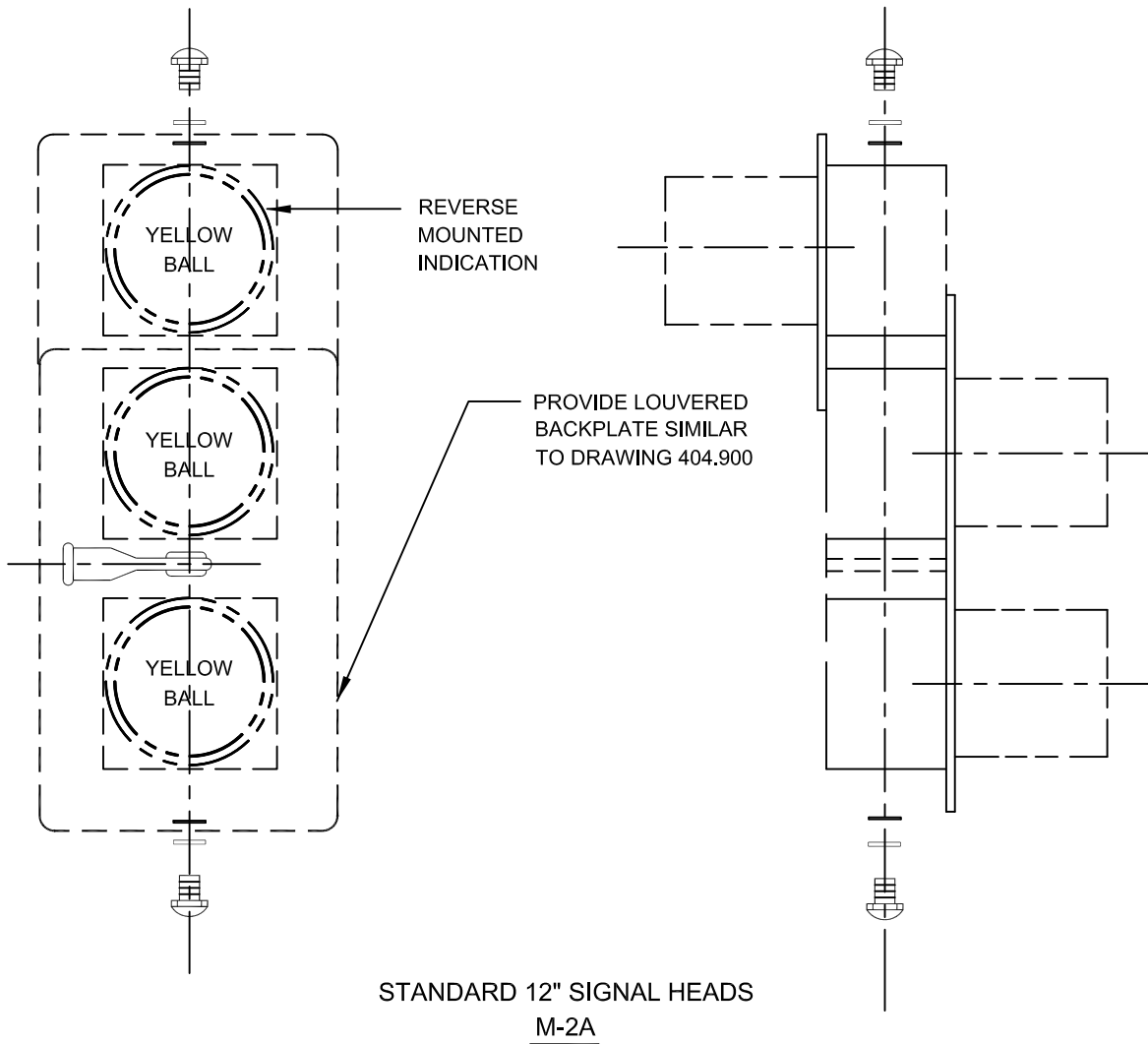

NOTES:

1. ALL INDICATIONS ARE TO BE YELLOW LED BALLS.
2. ALL M-2A INDICATIONS ARE 12" NOMINAL.
3. CIRCULAR VISORS TO BE INSTALLED ON ALL HEADS.
4. SEE SIGNAL PLANS FOR MAST ARM TENON LOCATIONS.
5. THIS HEAD ASSEMBLY SHALL BE USED ONLY ON THE END OF THE MAST ARM.

SPECIFICATION REFERENCE

UNIFORM STANDARD DRAWINGS
CLARK COUNTY AREA

SCHOOL FLASHER
MAST ARM SIGNAL ASSEMBLIES
M-2A

PROVIDE LOUVERED
BACKPLATE SIMILAR
TO DRAWING 404.900

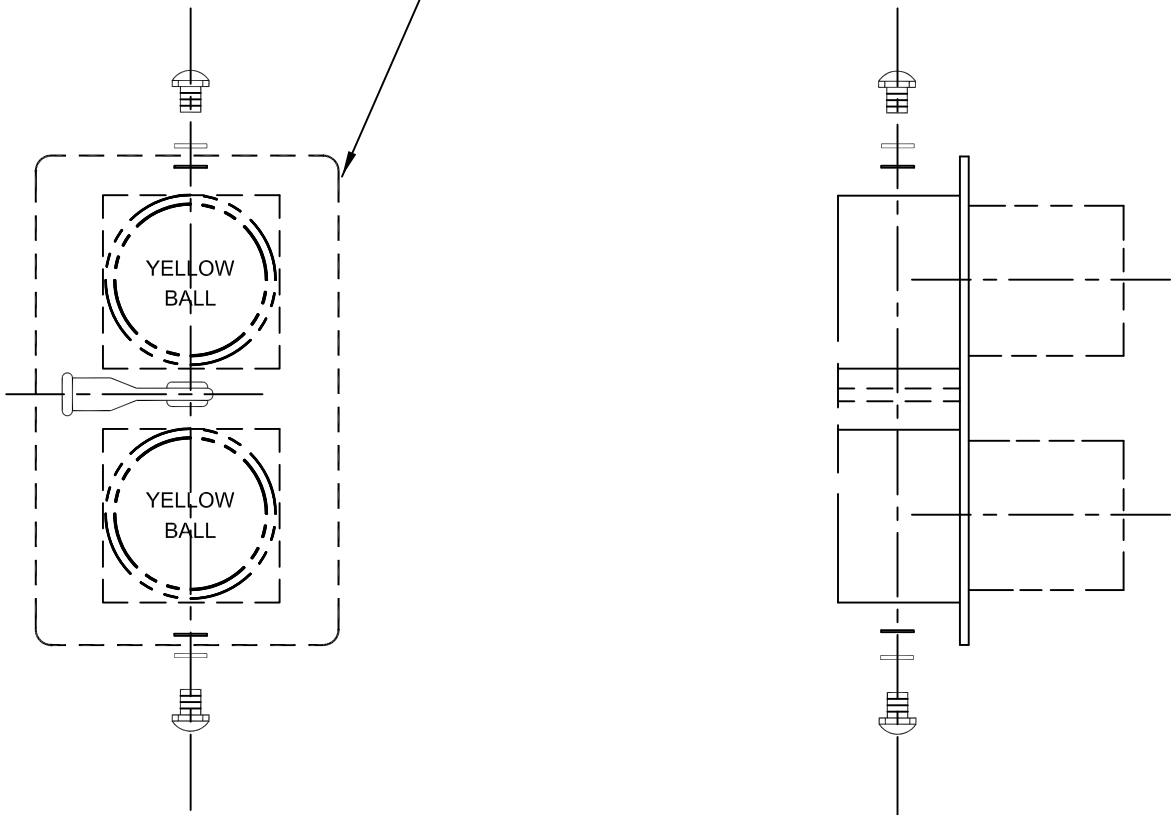

STANDARD 12" SIGNAL HEADS
M-2B

NOTES:

1. ALL INDICATIONS ARE TO BE YELLOW LED BALLS.
2. ALL M-2B INDICATIONS ARE 12" NOMINAL.
3. CIRCULAR VISORS TO BE INSTALLED ON ALL HEADS.
4. SEE SIGNAL PLANS FOR MAST ARM TENON LOCATIONS.

SPECIFICATION REFERENCE

UNIFORM STANDARD DRAWINGS
CLARK COUNTY AREA

SCHOOL FLASHER
MAST ARM SIGNAL ASSEMBLIES
M-2B

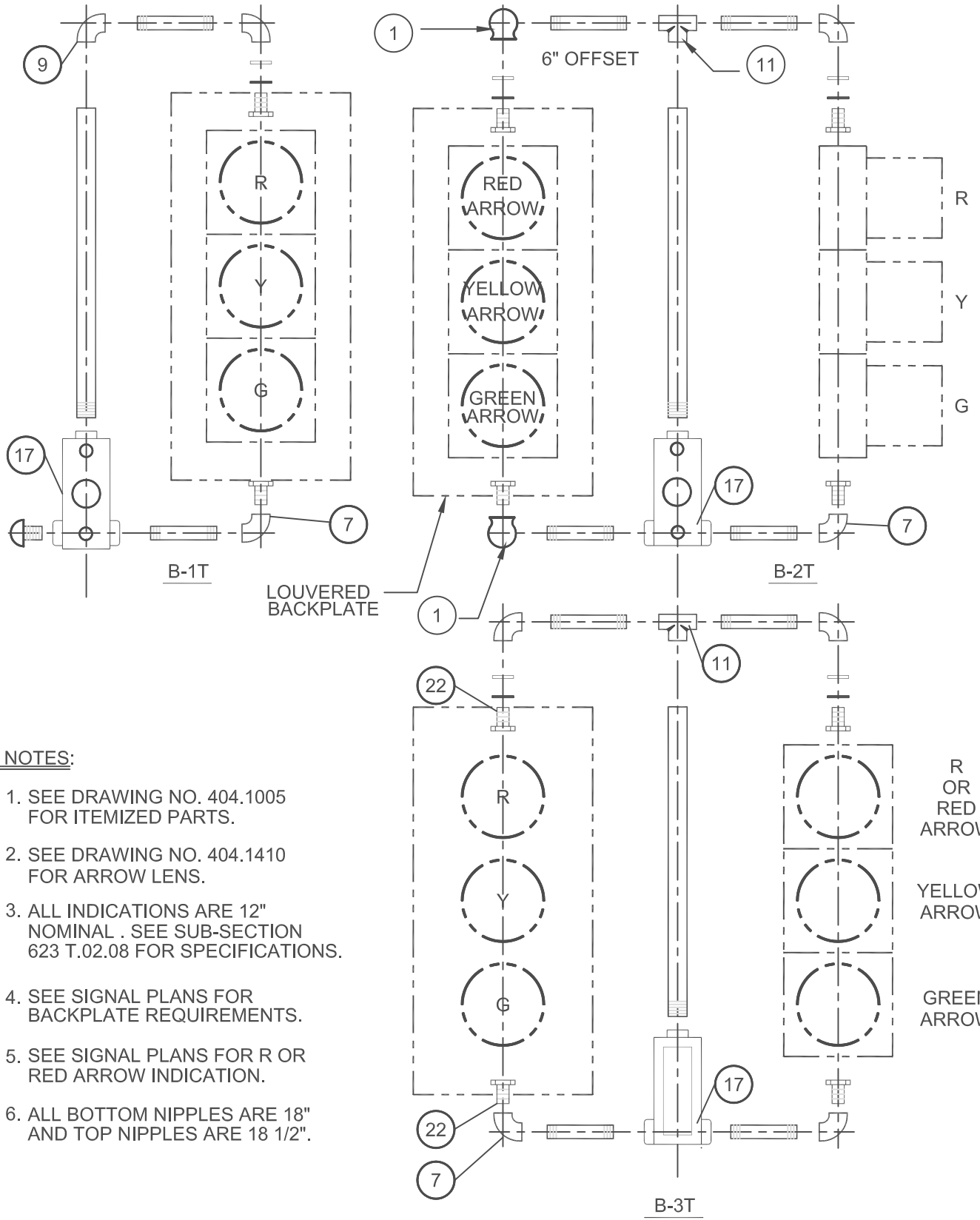

NOTES:

1. SEE DRAWING NO. 404.1005 FOR ITEMIZED PARTS.
2. SEE DRAWING NO. 404.1410 FOR ARROW LENS.
3. ALL INDICATIONS ARE 12" NOMINAL . SEE SUB-SECTION 623 T.02.08 FOR SPECIFICATIONS.
4. SEE SIGNAL PLANS FOR BACKPLATE REQUIREMENTS.
5. SEE SIGNAL PLANS FOR R OR RED ARROW INDICATION.
6. ALL BOTTOM NIPPLES ARE 18" AND TOP NIPPLES ARE 18 1/2".

SPECIFICATION REFERENCE

UNIFORM STANDARD DRAWINGS
CLARK COUNTY AREA

SIGNAL ASSEMBLIES
B-1T, B-2T, B-3T

DATE:10-9-08

DWG. NO. 404.1024

SHEET 1 OF 1

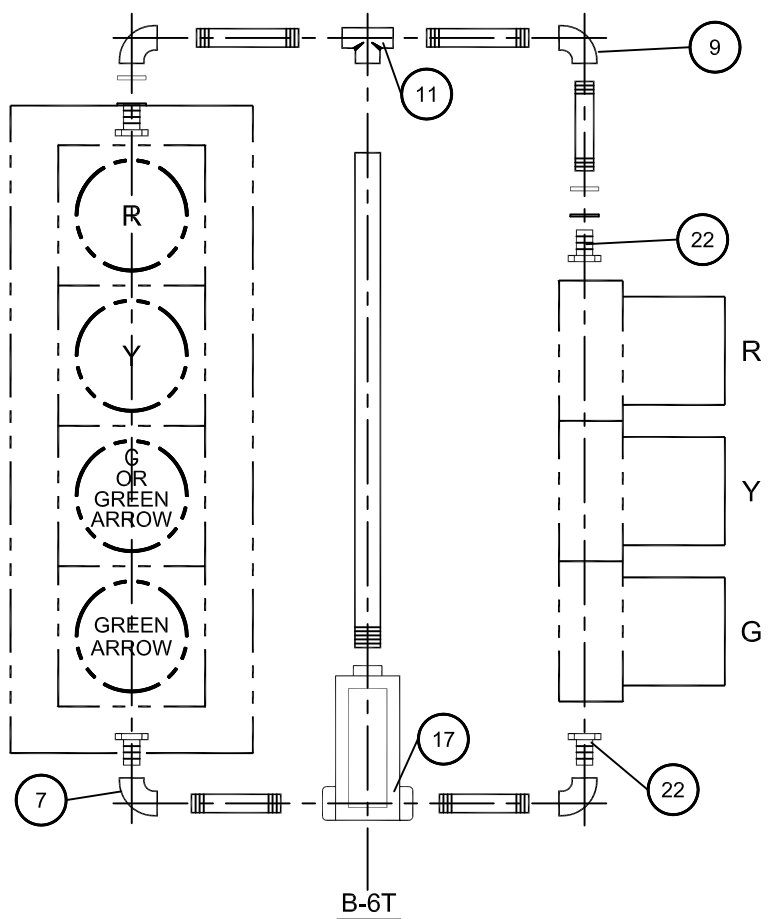
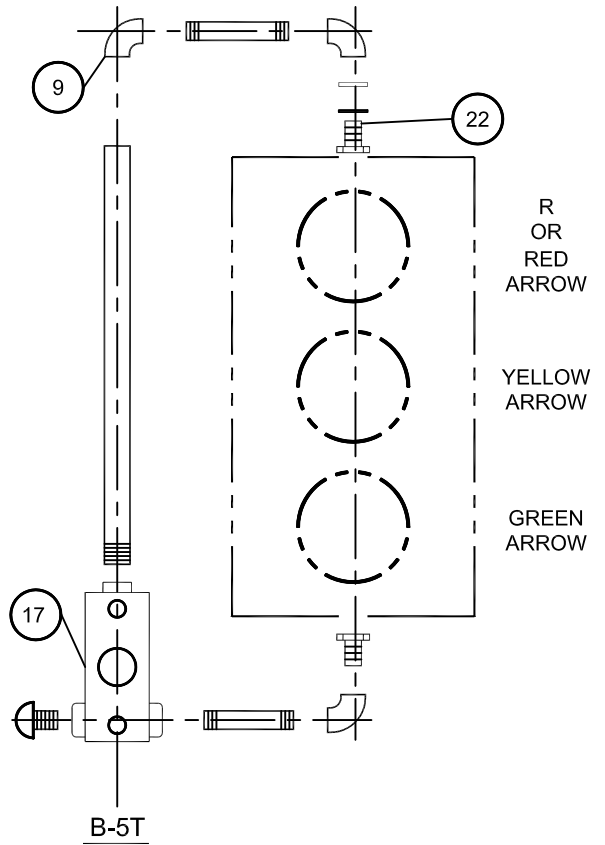

NOTES:

1. SEE DRAWING NO. 404.1005 FOR ITEMIZED PARTS.
2. SEE DRAWING NO. 404.1410 FOR ARROW LENS.
3. ALL INDICATIONS ARE 12" NOMINAL (GLASS).
4. SEE SIGNAL PLANS FOR BACKPLATE REQUIREMENTS.
5. SEE SIGNAL PLANS FOR R OR RED ARROW INDICATION.
6. ALL BOTTOM NIPPLES ARE 18" AND TOP NIPPLES ARE 18 1/2".

Effective 01/01/09 - 06/30/09

SPECIFICATION REFERENCE		UNIFORM STANDARD DRAWINGS CLARK COUNTY AREA		
		SIGNAL ASSEMBLIES B-5T, B-6T		
DATE	2-11-93	DWG. NO.	404.1025	SHEET 1 OF 1

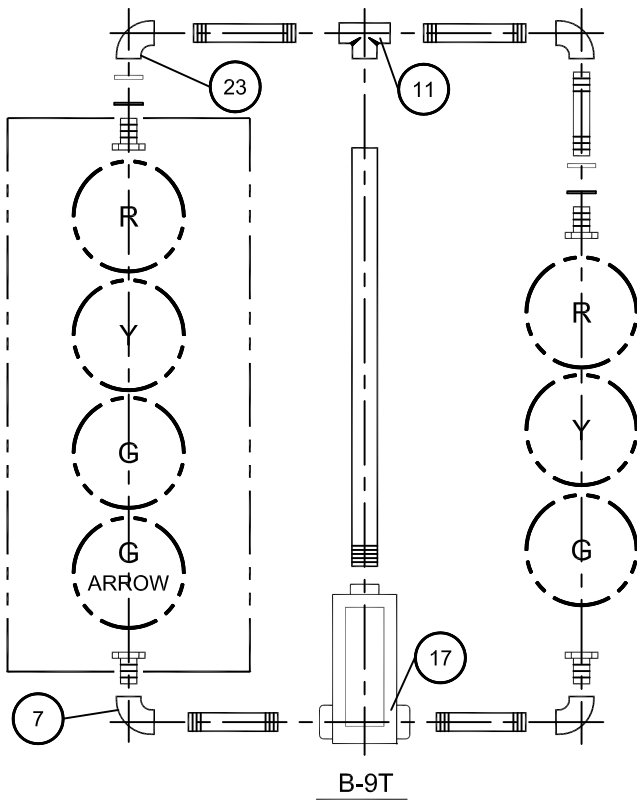
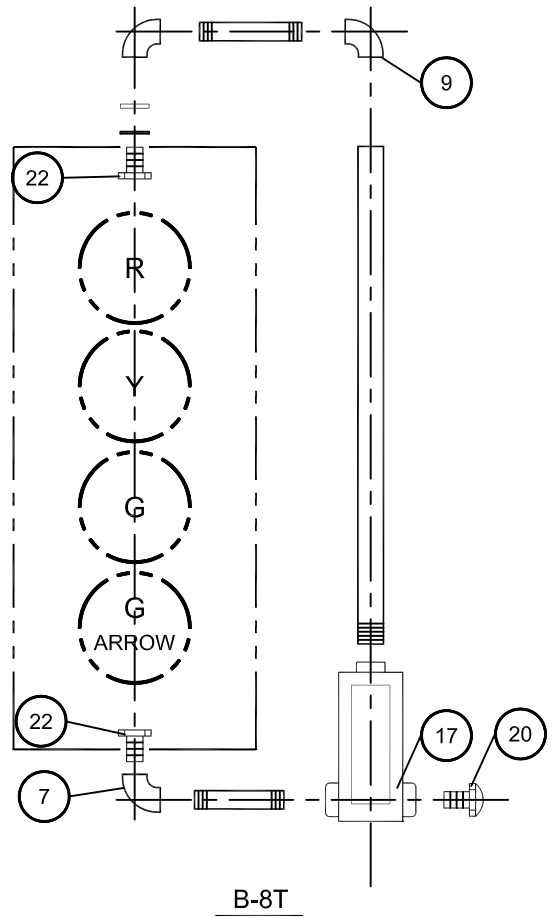
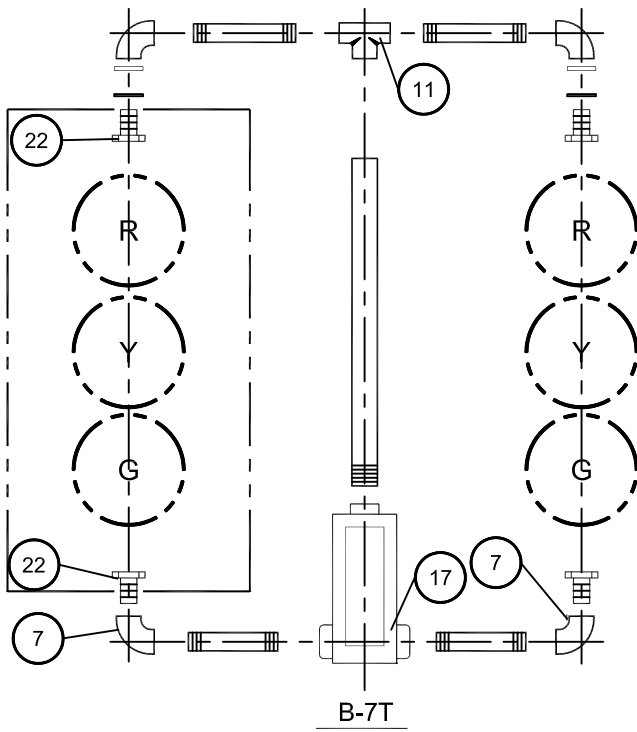

NOTES:

1. FOR ITEMIZED PARTS, SEE DRAWING NO. 404.1005.
2. FOR ARROW LENS SEE DRAWING NO. 404.1410.
3. ALL SIGNALS ARE 12" NOMINAL (GLASS) UNLESS NOTED.

SPECIFICATION REFERENCE

UNIFORM STANDARD DRAWINGS
CLARK COUNTY AREA

SIGNAL ASSEMBLIES
B-7T, B-8T, B-9T

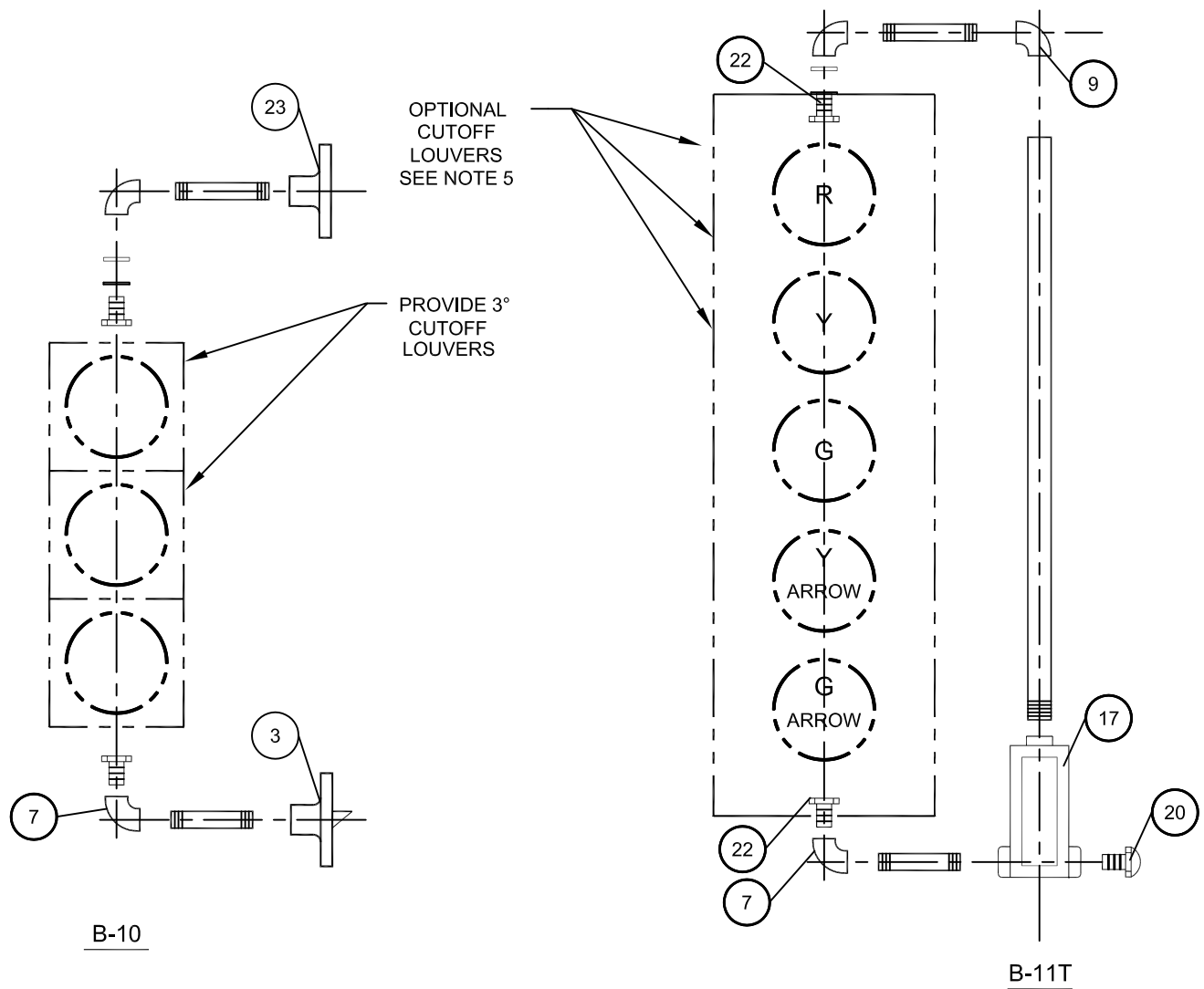

NOTES:

1. ALL SIGNALS ARE 12" NOMINAL (GLASS).
2. FOR ITEMIZED PARTS SEE DRAWING 404.1005.
3. FOR ARROW LENS SEE DRAWING 404.1410.
4. SEE PLANS FOR BACKPLATE REQUIREMENTS.
5. OPTIONAL 3° CUTOFF LOUVERS ON RED, YELLOW AND GREEN BALL INDICATIONS ON 5-SECTION HEADS MAY BE PROVIDED AS DIRECTED BY THE TRAFFIC ENGINEER.

SPECIFICATION REFERENCE

UNIFORM STANDARD DRAWINGS
CLARK COUNTY AREA

SIGNAL ASSEMBLIES
B-10, B-11T

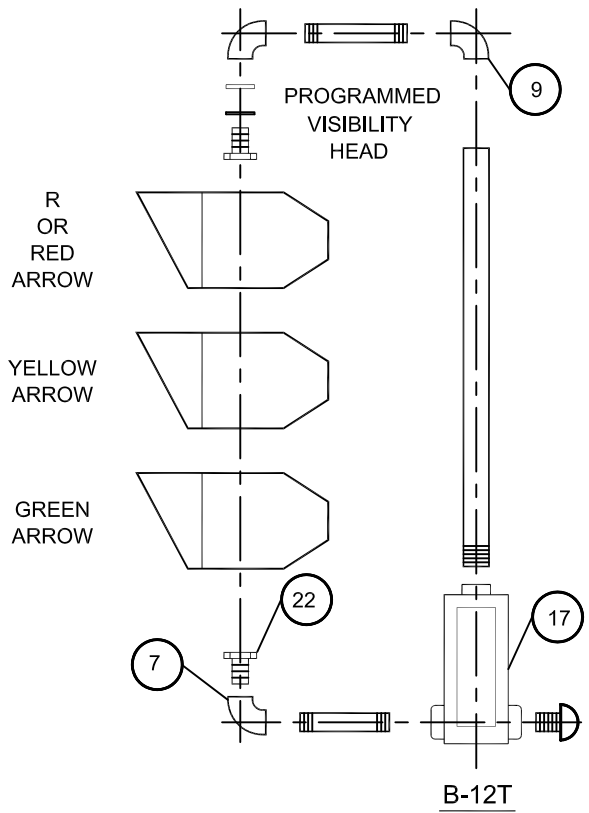

B-12T

NOTES:

1. SEE DRAWING NO. 404.1005 FOR ITEMIZED PARTS.
2. SEE STANDARD SPECIFICATIONS FOR PROGRAMMED VISIBILITY HEADS.
3. SEE SIGNAL PLANS FOR BACKPLATE REQUIREMENTS.
4. SEE SIGNAL PLANS FOR R OR RED ARROW INDICATION.
5. ALL BOTTOM NIPPLES ARE 18" AND TOP NIPPLES ARE 18 1/2".

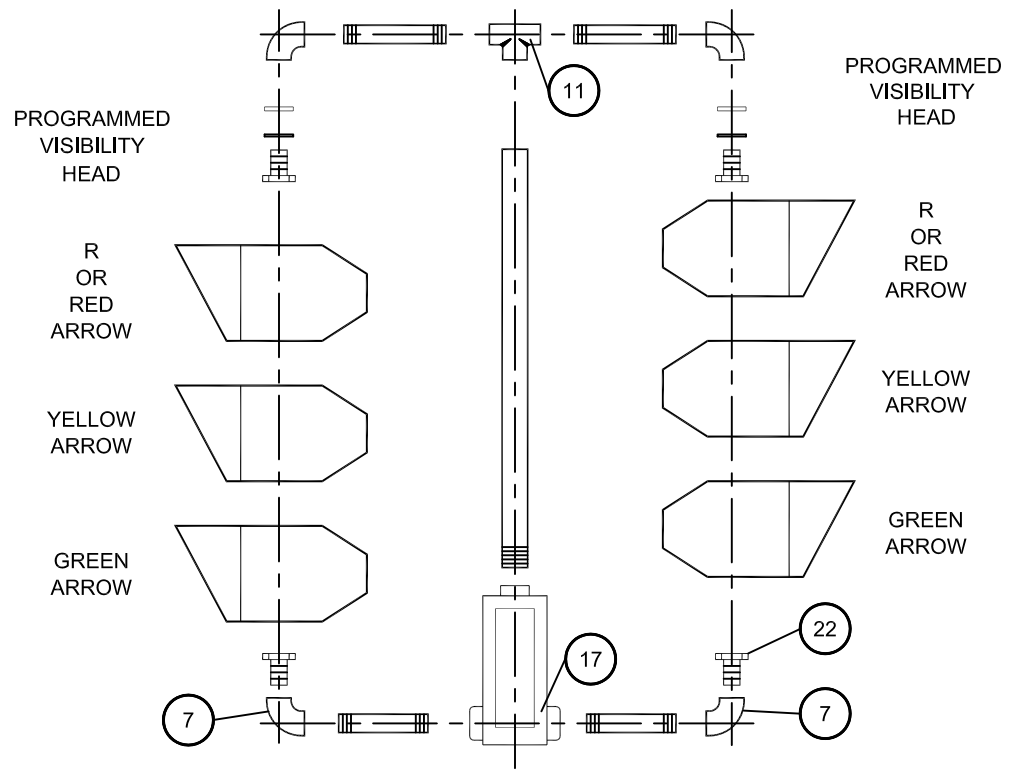

B-13T

Effective 01/01/09 - 06/30/09

SPECIFICATION REFERENCE		UNIFORM STANDARD DRAWINGS CLARK COUNTY AREA			
		SIGNAL ASSEMBLIES B-12T, B-13T			
DATE	2-11-93	DWG. NO.	404.1028	SHEET	1 OF 1

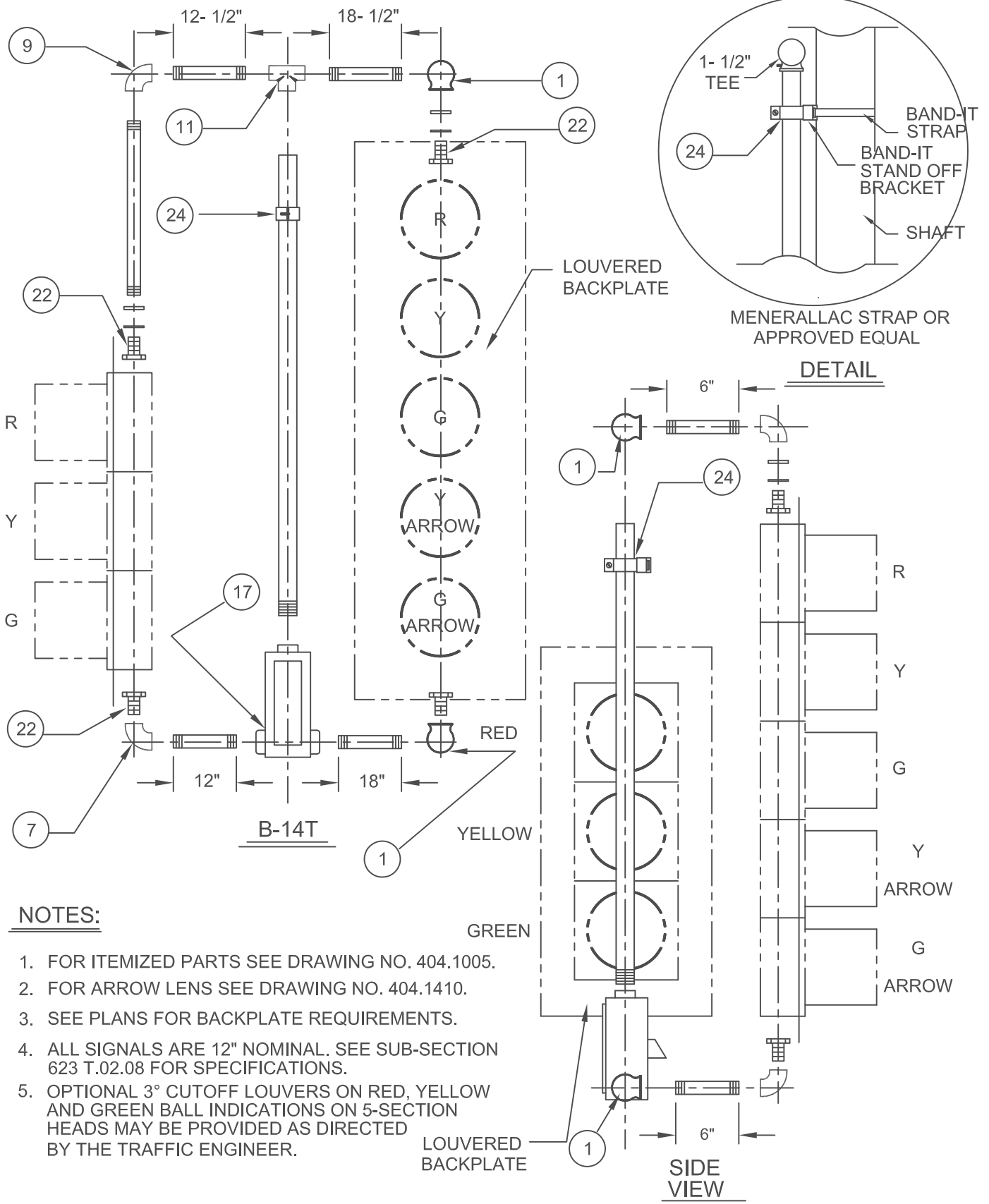

NOTES:

1. FOR ITEMIZED PARTS SEE DRAWING NO. 404.1005.
2. FOR ARROW LENS SEE DRAWING NO. 404.1410.
3. SEE PLANS FOR BACKPLATE REQUIREMENTS.
4. ALL SIGNALS ARE 12" NOMINAL. SEE SUB-SECTION 623 T.02.08 FOR SPECIFICATIONS.
5. OPTIONAL 3° CUTOFF LOUVERS ON RED, YELLOW AND GREEN BALL INDICATIONS ON 5-SECTION HEADS MAY BE PROVIDED AS DIRECTED BY THE TRAFFIC ENGINEER.

SPECIFICATION REFERENCE

UNIFORM STANDARD DRAWINGS
CLARK COUNTY AREA

SIGNAL ASSEMBLIES
B-14T

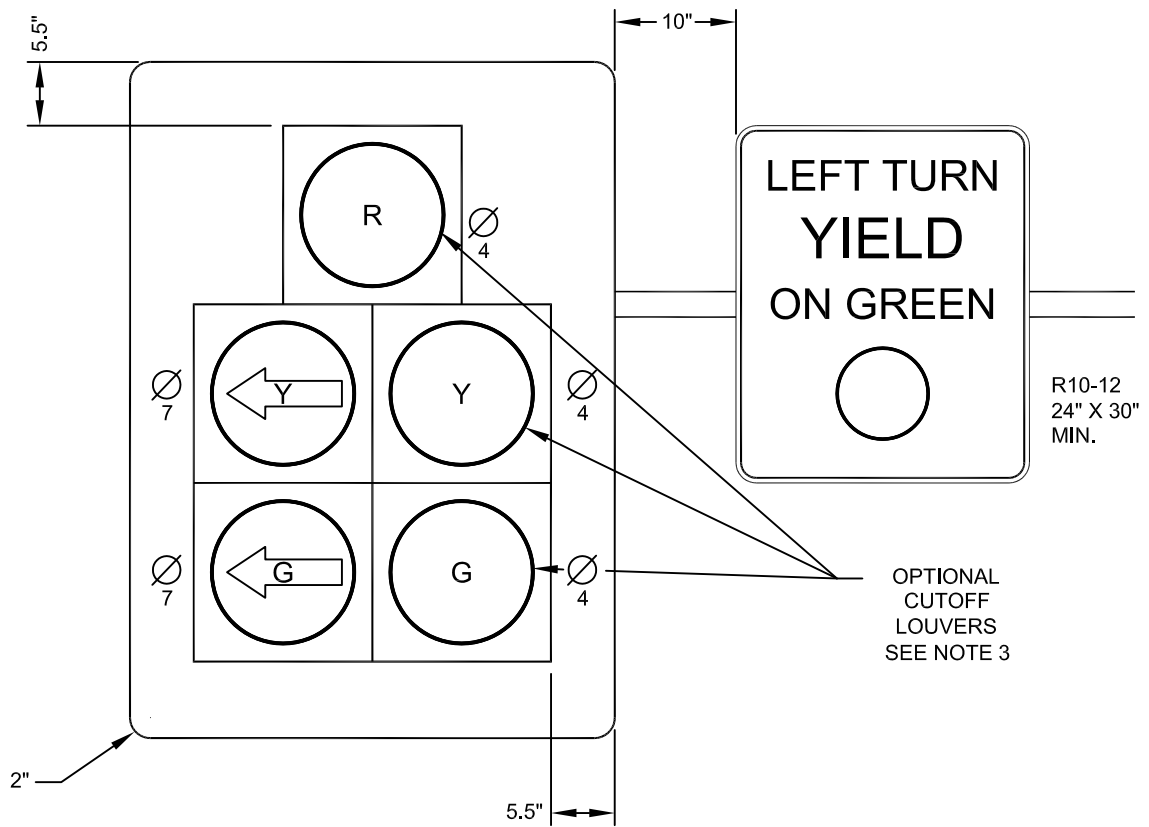

NOTES:

1. ALL BACKPLATES SHALL BE LOUVERED.
2. ALL LENSES SHALL BE GLASS.
3. OPTIONAL 3° CUTOFF LOUVERS ON RED, YELLOW AND GREEN BALL INDICATIONS MAY BE PROVIDED AS DIRECTED BY THE TRAFFIC ENGINEER.

SPECIFICATION REFERENCE

UNIFORM STANDARD DRAWINGS
CLARK COUNTY AREA

PROTECTED / PERMISSIVE
M-5 SIGNAL HEADS

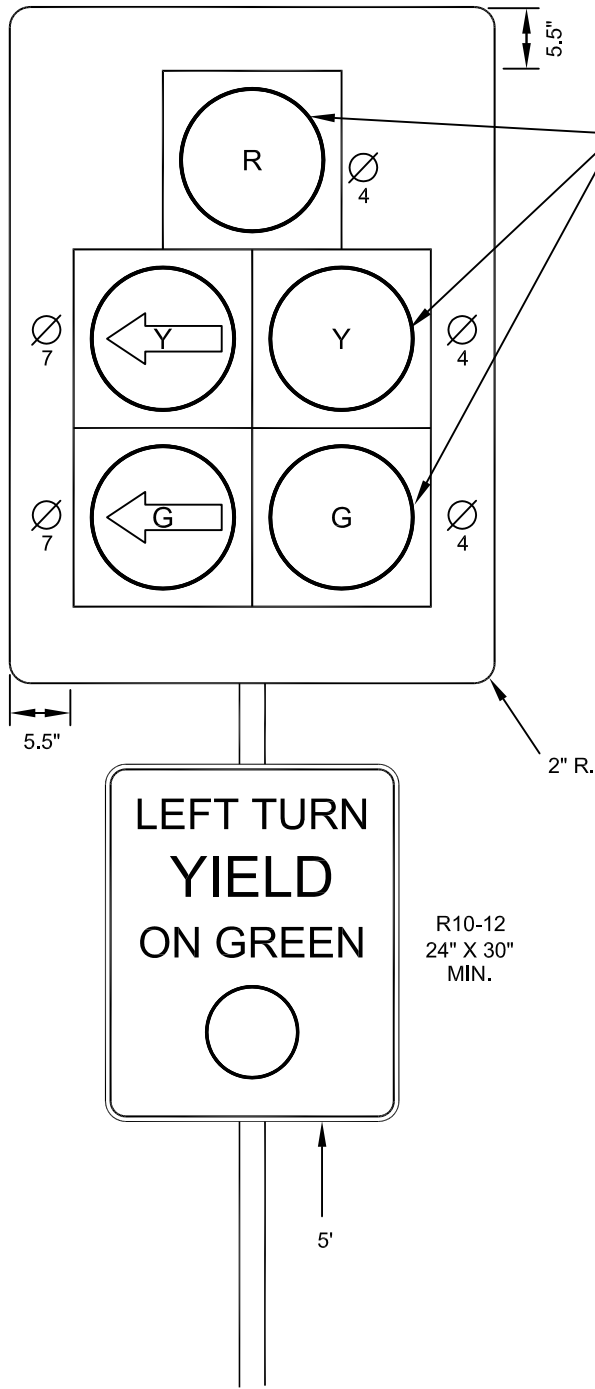

OPTIONAL
CUTOFF
LOUVERS
SEE NOTE 3

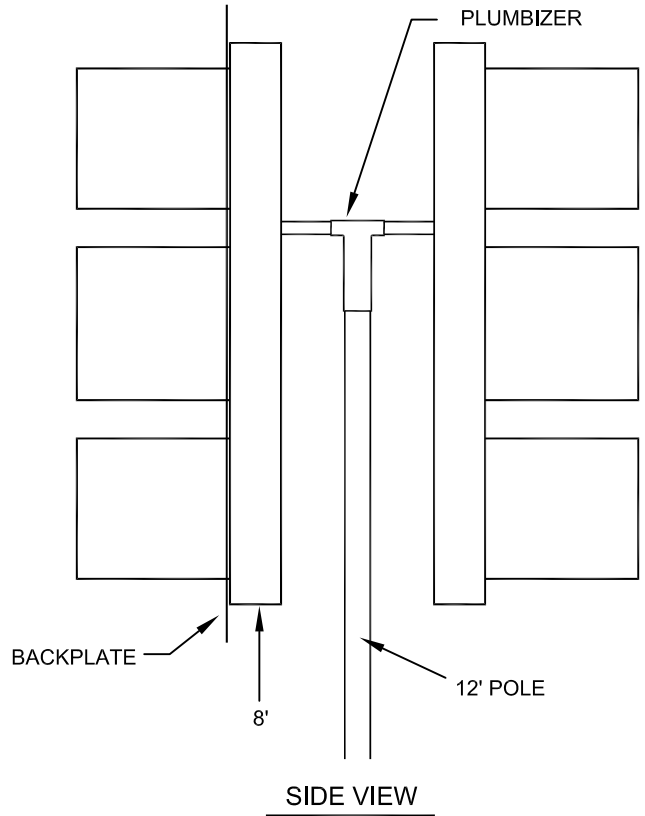
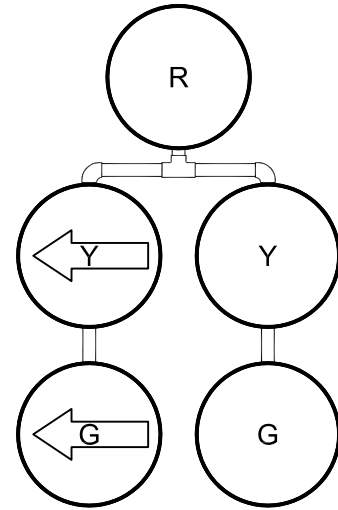

NOTES:

1. ALL BACKPLATES SHALL BE LOUVERED.
2. ALL LENSES SHALL BE GLASS.
3. OPTIONAL 3° CUTOFF LOUVERS ON RED, YELLOW AND GREEN BALL INDICATIONS MAY BE PROVIDED AS DIRECTED BY THE TRAFFIC ENGINEER.

SPECIFICATION REFERENCE

UNIFORM STANDARD DRAWINGS
CLARK COUNTY AREA

PROTECTED / PERMISSIVE
M-5 SIGNAL HEADS

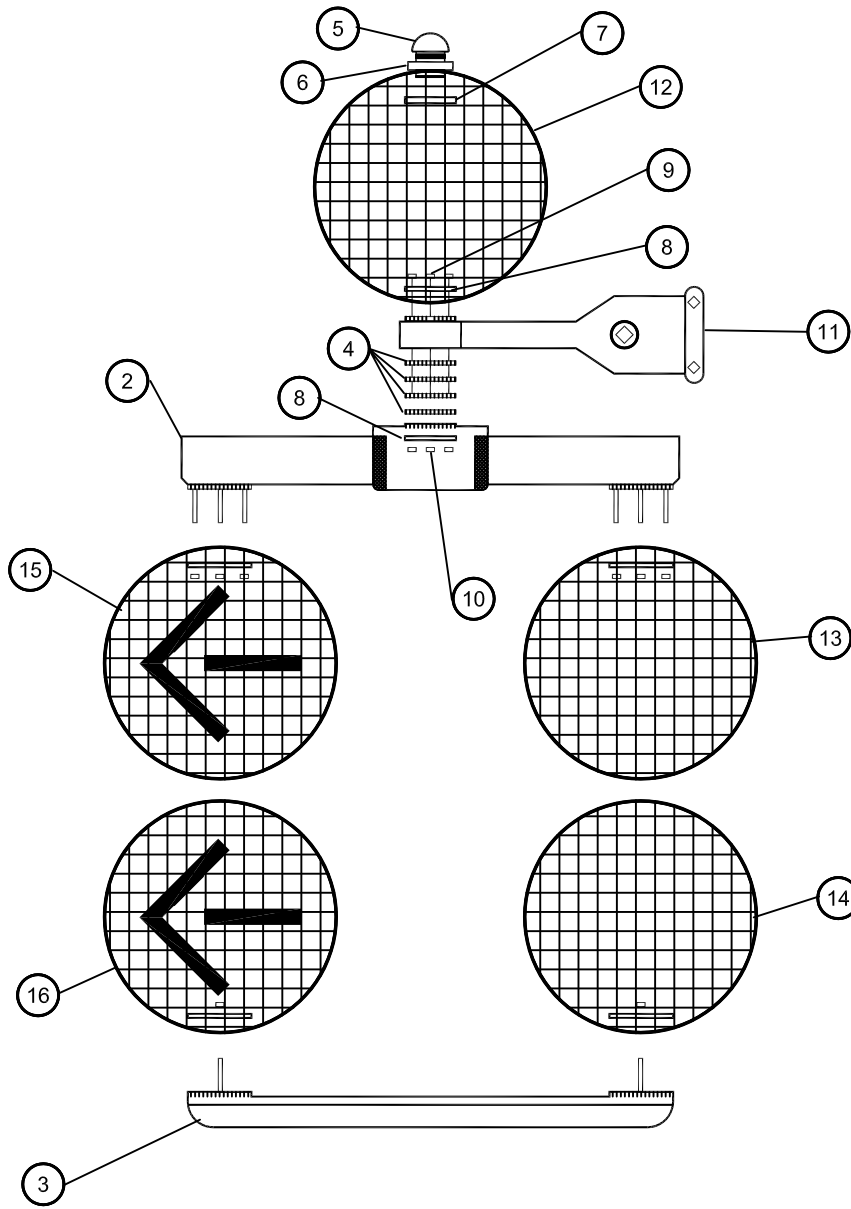

BACKPLATE TO MATCH
 ORDER PART NO. E 2074
 NOTES:
 UNLESS OTHERWISE SPECIFIED

1 ASSEMBLY

SPECIFICATION REFERENCE

UNIFORM STANDARD DRAWINGS
 CLARK COUNTY AREA

TYPE: M-5 ASSEMBLIES
 AND PARTS LIST

DATE

DWG. NO.

404.1031

SHEET

2 OF 3

FW 2933 AND SIGNAL ASSEMBLY

FRAMEWORK -- CLUSTER MOUNTING
 1 WAY, 5 COL., 12" ALUMINUM SIGNAL
 WITH ELEVATOR PLUMBIZER

<u>REF #</u>	<u>PART NO.</u>	<u>DESCRIPTION</u>	<u>REQ.</u>
1	FW2933	ASSEMBLY	X
2	E205P1	TOP BRACKET W/COVER	1
3	E2051P1	BOTTOM BRACKET	1
4	E1270P1	ADAPTOR RING	4
5	E1206P	ORNAMENT	1
6	E1251P1	WASHER, NEOPRENE	1
7	55712P6	CONDUIT LOCKNUT	1
8	E789P1	ATTACHING WASHER	2
9	E788P2	ATTACHING BOLT	3
10	N210P23C	ATTACHING NUT	3
11	FW0904G	ELEV. PLUMIZER, OLD STYLE (NO LONGER AVAILABLE)	1
12	E4955P1	RED BALL LENS	1
13	E4955P22	YELLOW BALL LENS	1
14	E4955P3	GREEN BALL LENS	1
15	E4960P2	YELLOW ARROW LENS	1
16	E4960P3	GREEN ARROW LENS	1
17	E2074G5	BACKPLATE	1

SPECIFICATION REFERENCE

UNIFORM STANDARD DRAWINGS
 CLARK COUNTY AREA

TYPE: M-5 ASSEMBLIES
 AND PARTS LIST

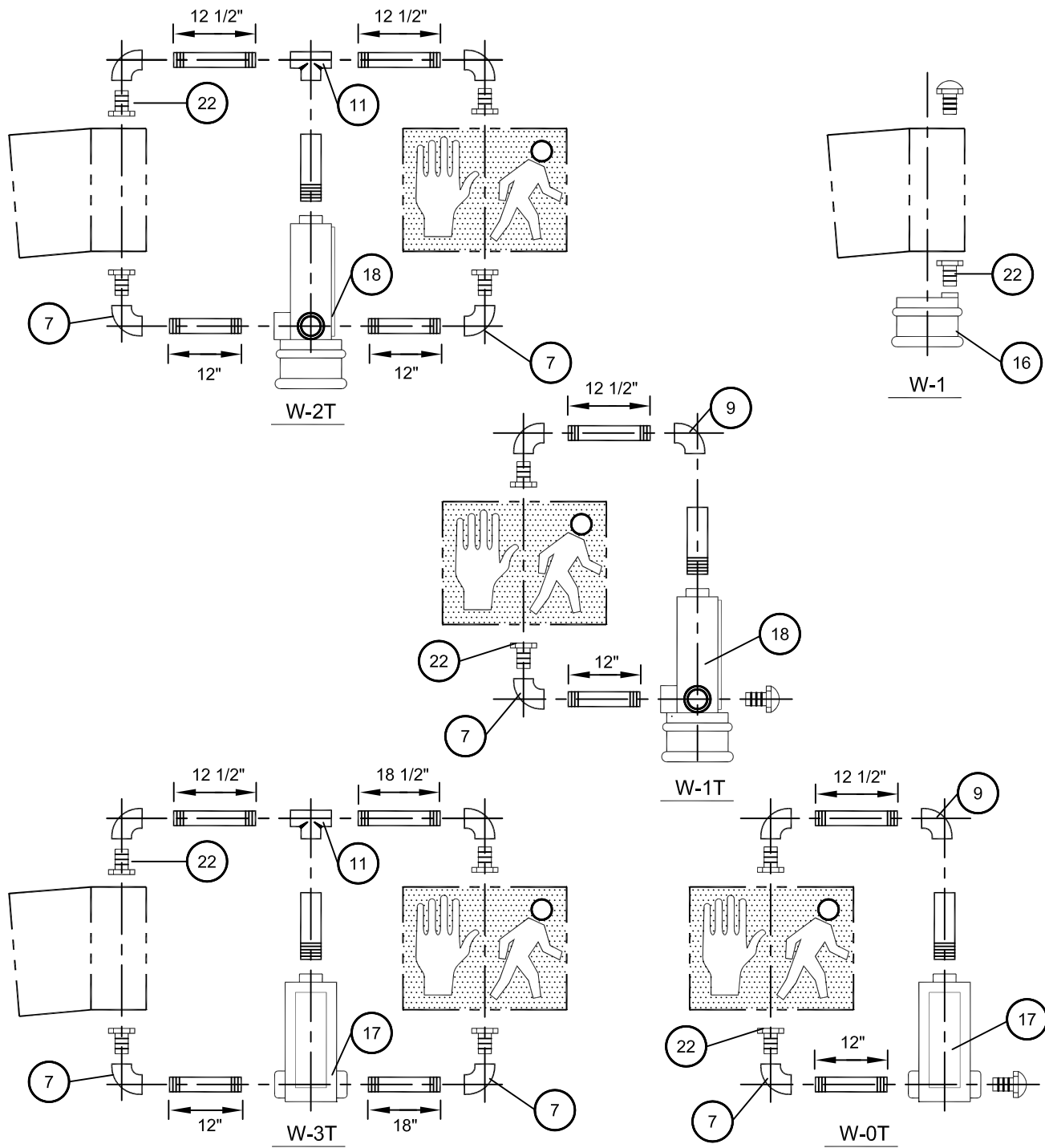

NOTES:

1. FOR GENERAL SPECIFICATIONS SEE TRAFFIC SIGNAL PLANS.
2. FOR ITEMIZED PARTS, SEE DRAWING NO. 404.1005.
3. THE HAND SYMBOL (DON'T WALK) IS PORTLAND ORANGE AND HUMAN SYMBOL (WALK) IS LUNAR WHITE.

SPECIFICATION REFERENCE

UNIFORM STANDARD DRAWINGS
CLARK COUNTY AREA

PEDESTRIAN SIGNAL ASSEMBLIES
W-0T, W-1, W-2T, W-3T, W-1T

NOTE: TAMPER-PROOF SCREWS TO BE USED.

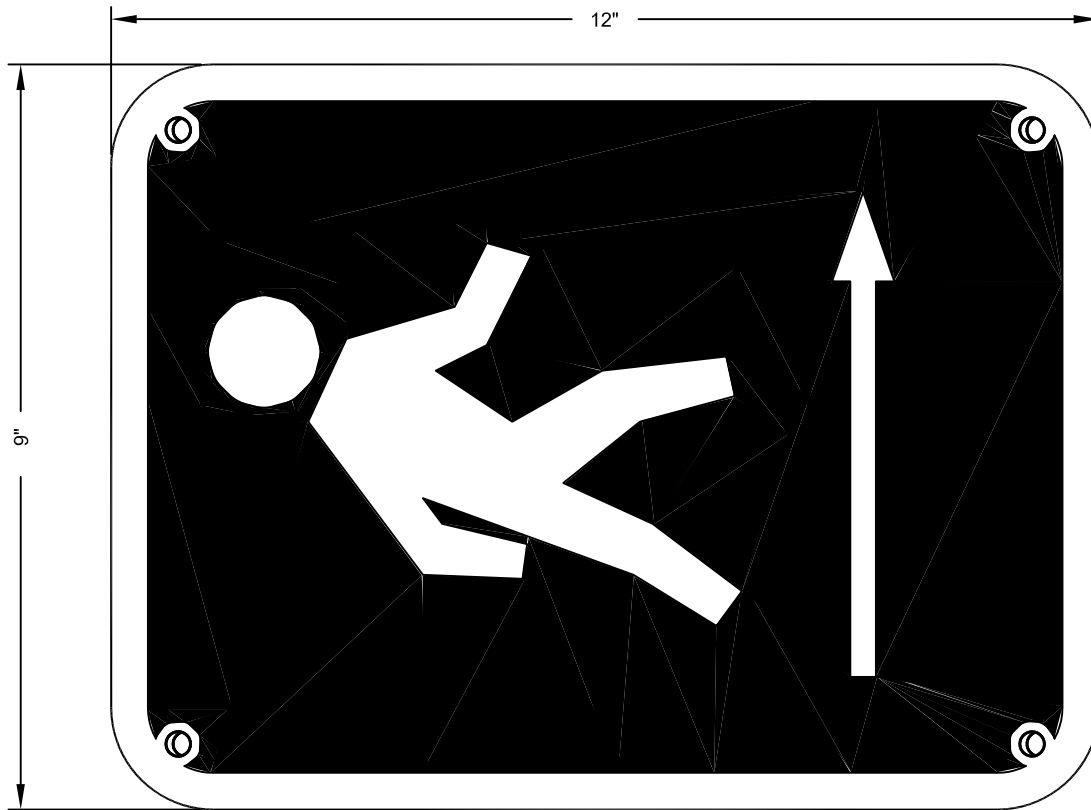
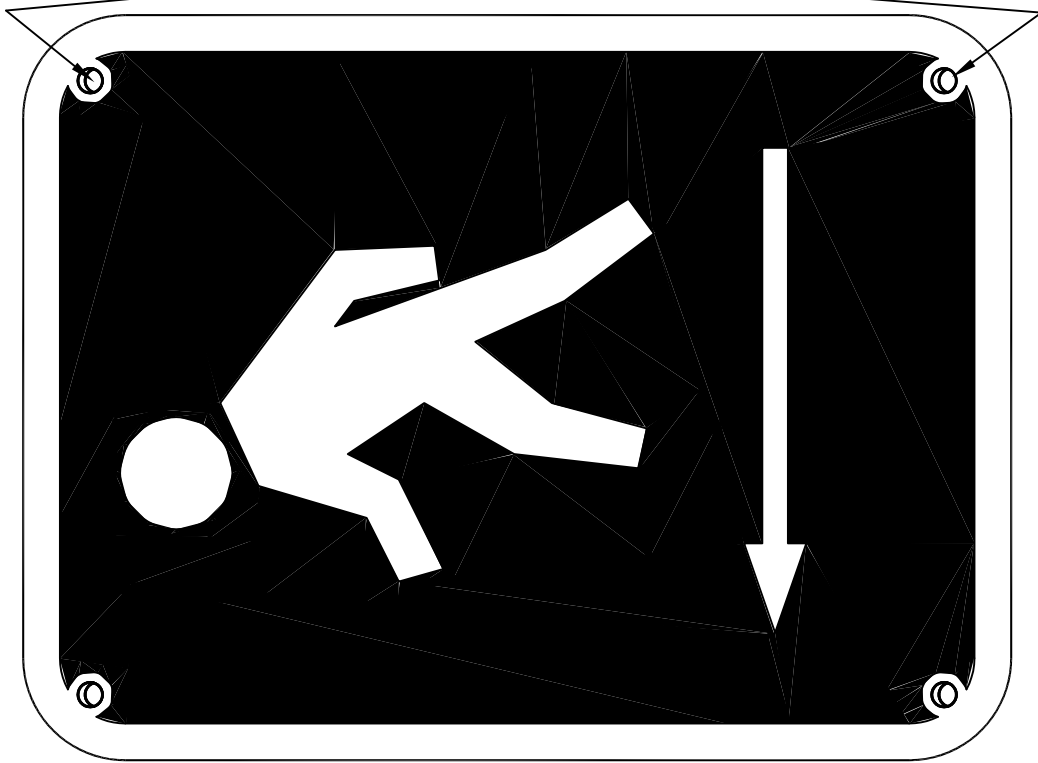

SPECIFICATION REFERENCE

UNIFORM STANDARD DRAWINGS
CLARK COUNTY AREA

PEDESTRIAN PUSH BUTTON
SIGN DETAIL

DATE

DWG. NO. 404.1034

SHEET 1 OF 1

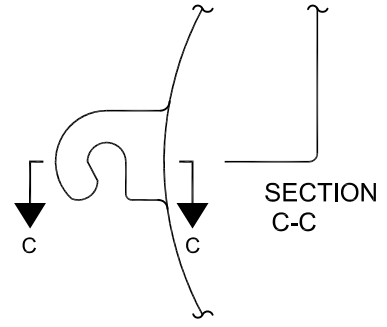
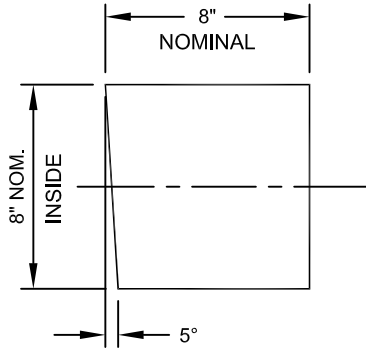
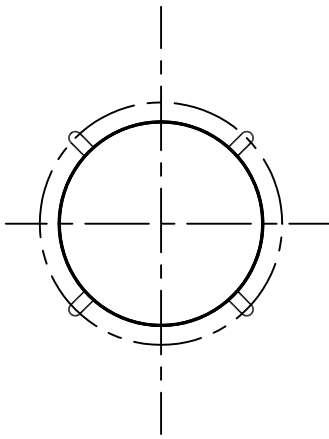

STANDARD FULL CIRCLE VISOR

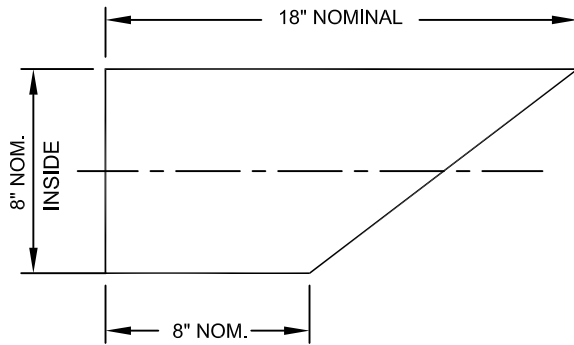
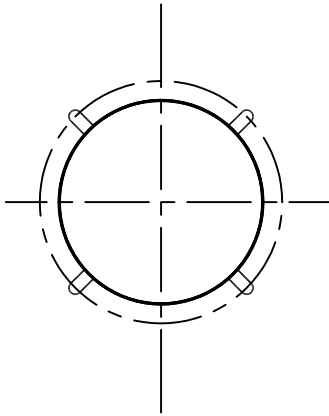

LEFT ANGLE-SHOWN
RIGHT ANGLE-REVERSE

STANDARD ANGLE VISOR

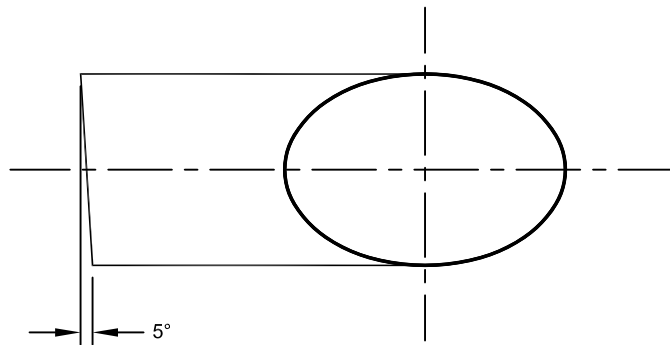

VISORS (FOR 8" HEADS)

PAINT: FLAT BLACK ON INSIDE,
OUTSIDE PAINT COLOR SHALL
MATCH SIGNAL HOUSING.

SPECIFICATION REFERENCE

UNIFORM STANDARD DRAWINGS
CLARK COUNTY AREA

VISORS
FOR 8" SIGNALS

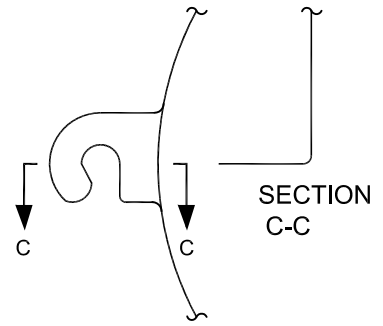
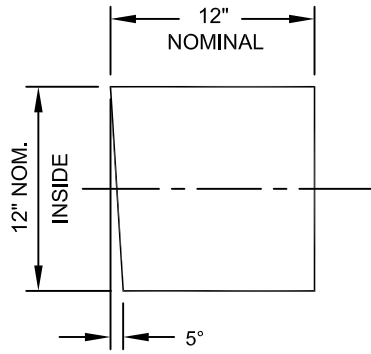
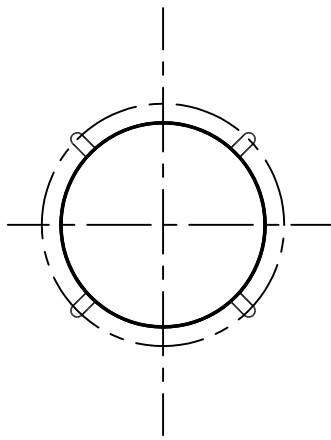

STANDARD FULL CIRCLE VISOR

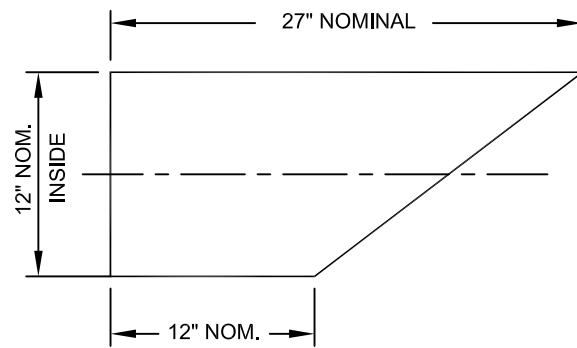
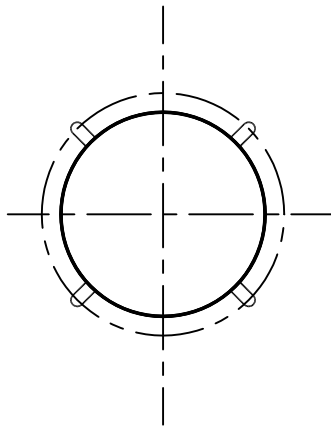

LEFT ANGLE-SHOWN
RIGHT ANGLE-REVERSE

STANDARD ANGLE VISOR

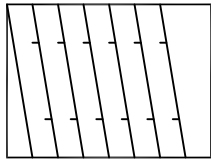

SECTION A-A

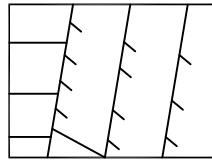

SECTION B-B

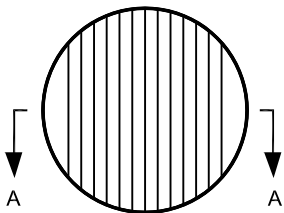

6 VANE
3° CUTOFF

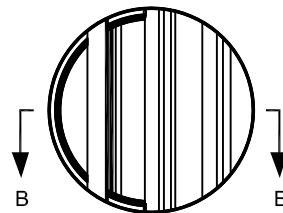

3 VANE
7° CUTOFF

DIRECTIONAL LOUVERS
PAINT: FLAT BLACK

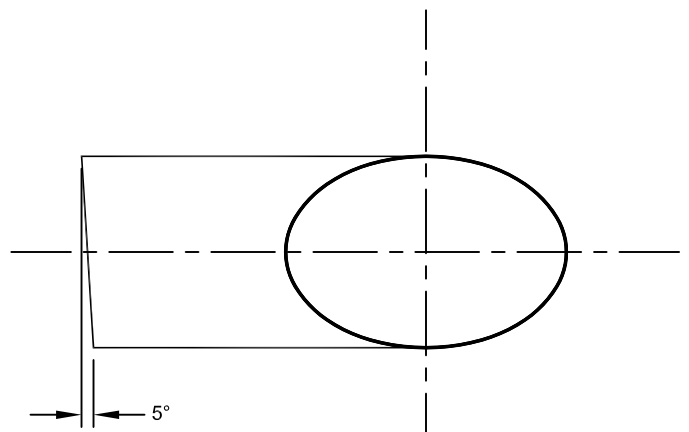

VISORS (FOR 12" HEADS)

PAINT: FLAT BLACK ON INSIDE,
OUTSIDE PAINT COLOR SHALL
MATCH SIGNAL HOUSING.

SPECIFICATION REFERENCE

UNIFORM STANDARD DRAWINGS
CLARK COUNTY AREA

LOUVERS AND VISORS
FOR 12" SIGNALS

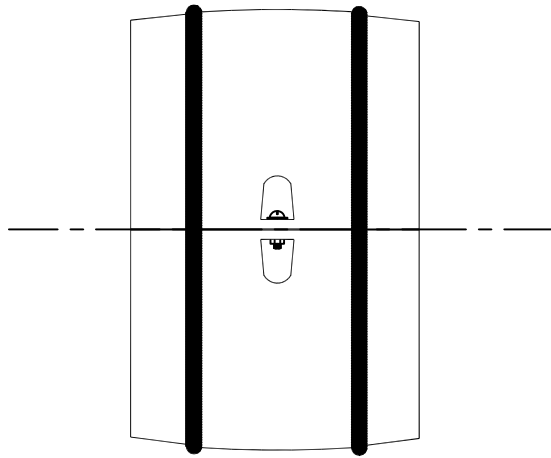

SIDE VIEW

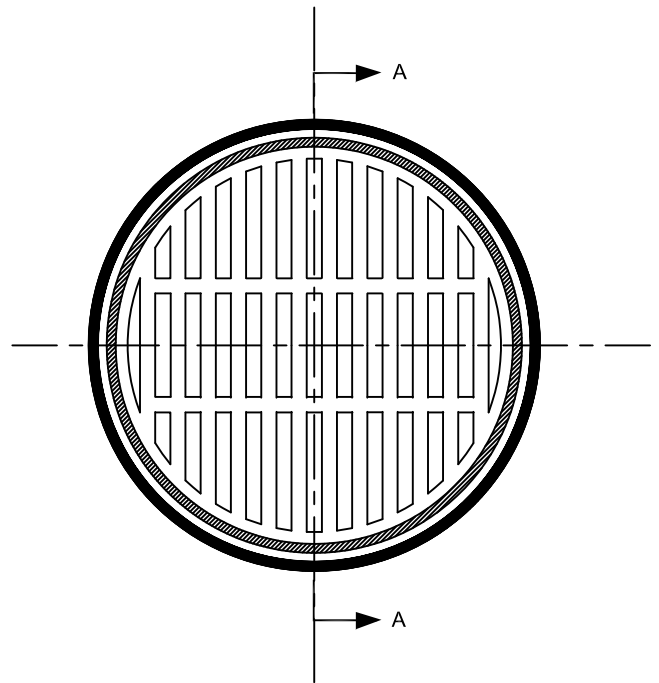

FRONT VIEW

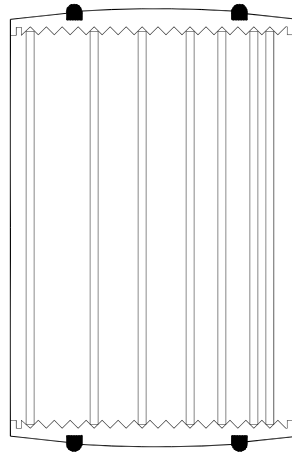

SECTION A-A

SPECIFICATION REFERENCE

UNIFORM STANDARD DRAWINGS
CLARK COUNTY AREA

GEOMETRICALLY PROGRAMMED
LOUVER

DATE

DWG. NO.

404.1100

SHEET

3 OF 3

Effective 01/01/09 - 06/30/09

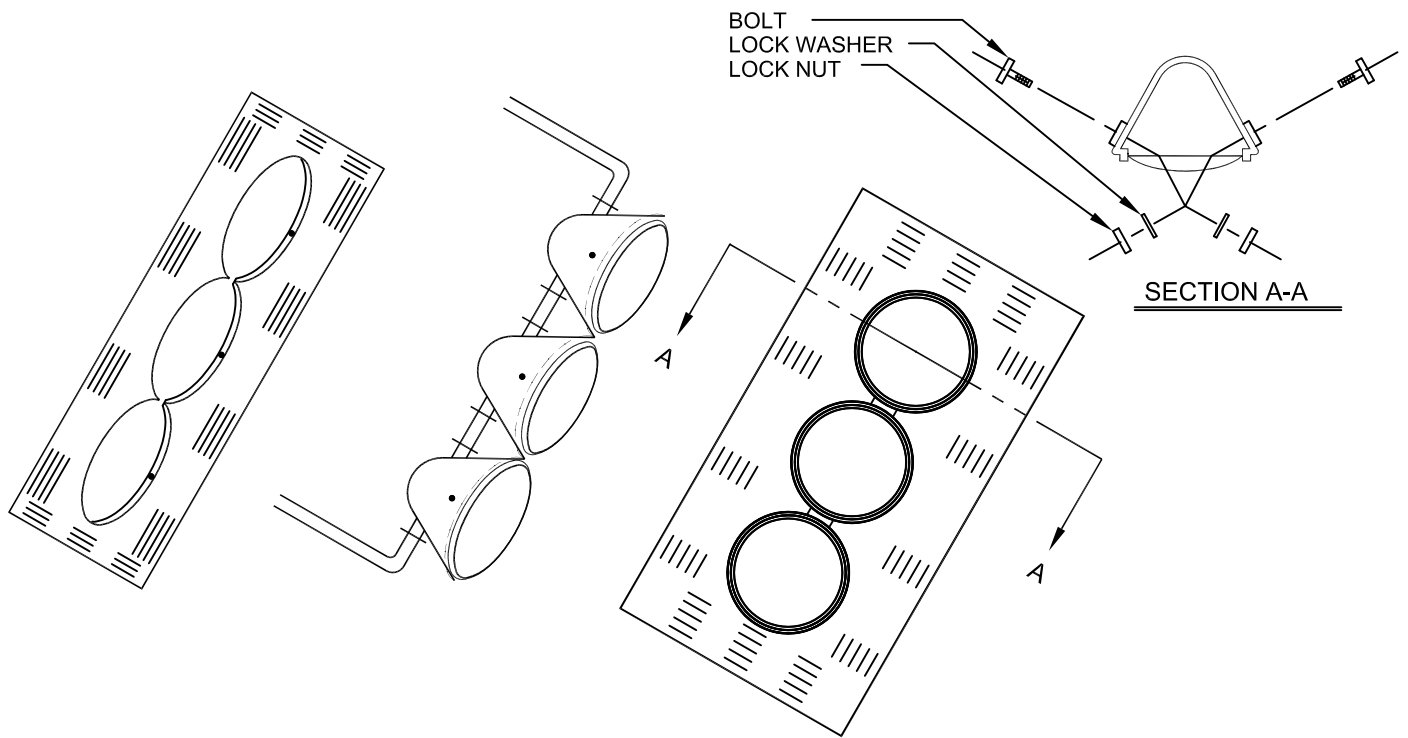

NOTE:

ALL BOLTS, NUTS AND WASHERS SHALL BE BRASS OR STAINLESS STEEL.

SPECIFICATION REFERENCE		UNIFORM STANDARD DRAWINGS CLARK COUNTY AREA		
		BACKPLATE AND SIGNAL HEAD ASSEMBLY		
		DATE 12-12-96	DWG. NO. 404.1101	SHEET 1 OF 1

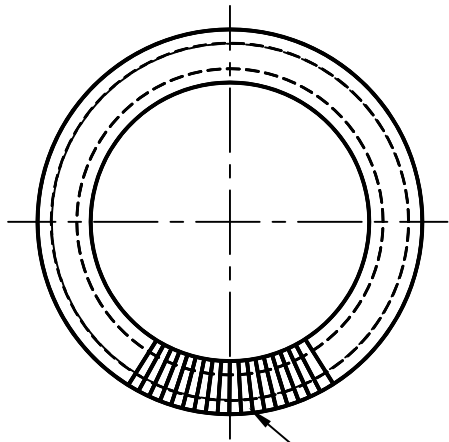

72 TEETH - 1/2"
HIGH ALL AROUND

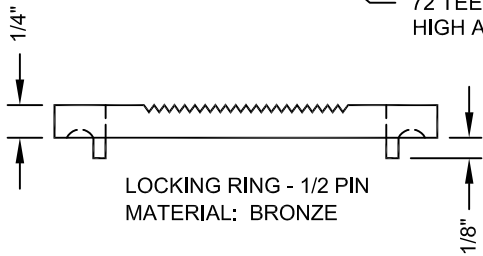

LOCKING RING - 1/2 PIN
MATERIAL: BRONZE

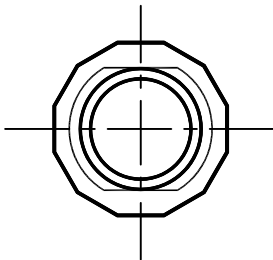
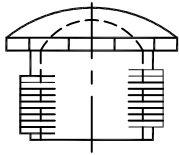

ORNAMENTAL CAP
DIE CAST ALUMINUM
PAINT COLOR SHALL MATCH
SIGNAL HOUSING



TIE BRACE, FERROUS, 2 WAY
PAINT COLOR SHALL MATCH
SIGNAL HOUSING

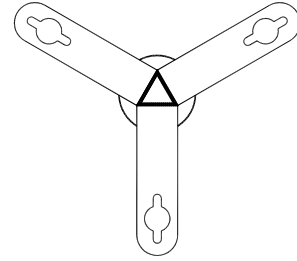

TIE BRACE, FERROUS, 3 WAY
PAINT COLOR SHALL MATCH
SIGNAL HOUSING

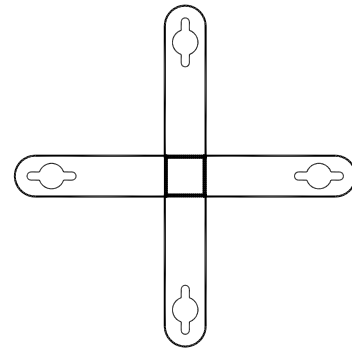

TIE BRACE, FERROUS, 4 WAY
PAINT COLOR SHALL MATCH
SIGNAL HOUSING

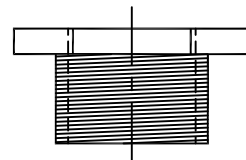
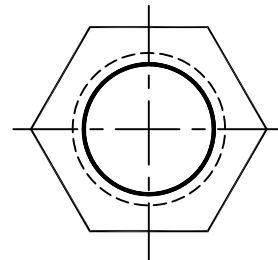

LOCKING NIPPLE

SPECIFICATION REFERENCE

UNIFORM STANDARD DRAWINGS
CLARK COUNTY AREA

MISCELLANEOUS SIGNAL
MOUNTING HARDWARE

DATE	DWG. NO.	404.1200	SHEET	1 OF 1
------	----------	----------	-------	--------

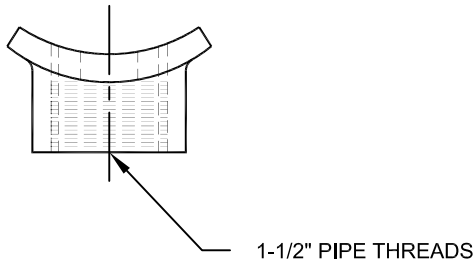

NOTES:

1. MATERIAL-BRONZE
2. PAINT COLOR SHALL MATCH SIGNAL HOUSING
3. PROVIDE WASHERS SHOWN AND 1/2" PLATED BOLTS, LENGTH FOR STEEL POLE MOUNTING.

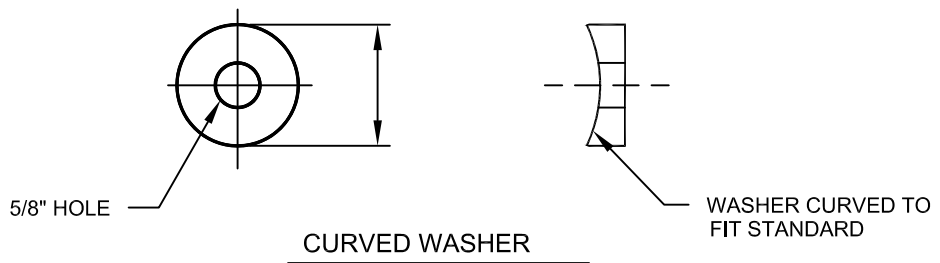
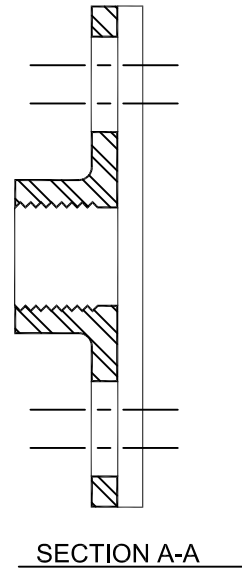
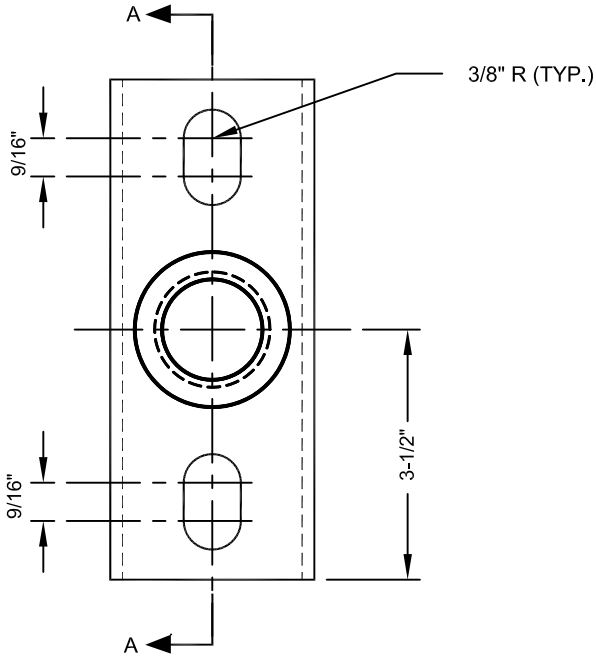

NOTES: DO NOT PROVIDE UNLESS SPECIFIED ON THE PLANS.

SPECIFICATION REFERENCE

UNIFORM STANDARD DRAWINGS
CLARK COUNTY AREA

POLE PLATE
DETAILS

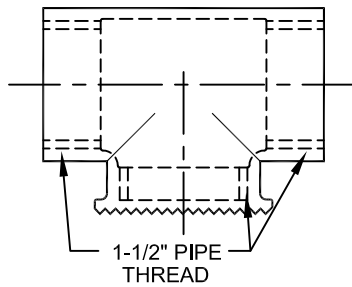

72 TEETH - 1/16" HIGH ALL AROUND

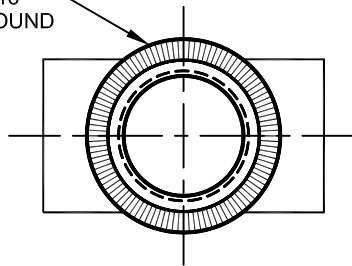

FERROUS SPECIAL TEE
PAINT COLOR SHALL MATCH
SIGNAL HOUSING

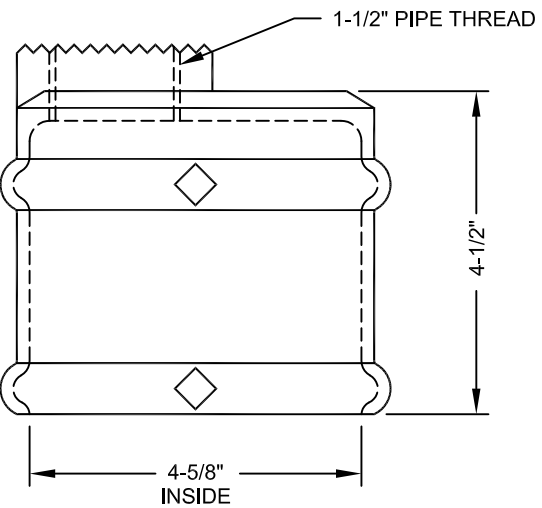
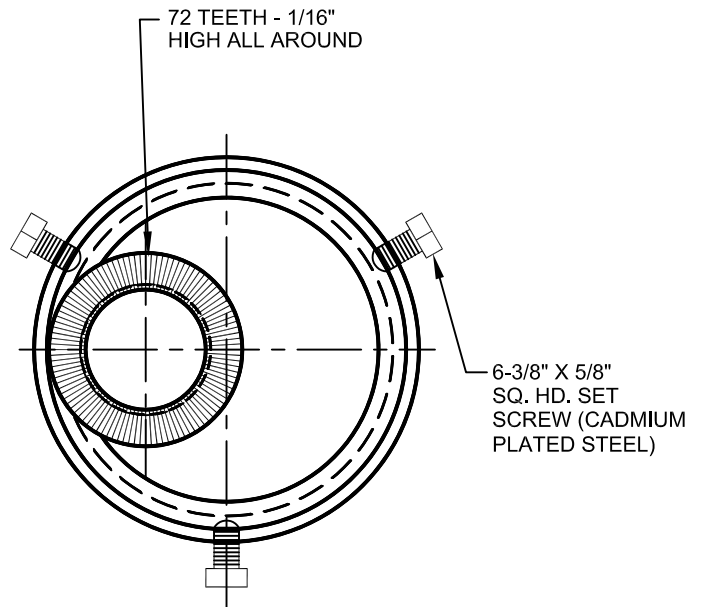

POST TOP MOUNTED BRACKET WITH
SERRATED OFFSET MOUNT.

(USE FOR ALL POST TOP MOUNTINGS
NOT REQUIRING SIDE PORTS)

MATERIAL: BRONZE
PAINT COLOR SHALL MATCH
SIGNAL HOUSING

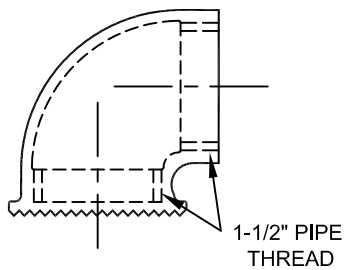

72 TEETH - 1/16" HIGH ALL AROUND

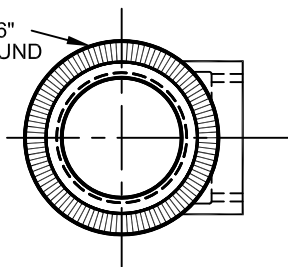

FERROUS SPECIAL ELBOW
PAINT COLOR SHALL MATCH
SIGNAL HOUSING

SPECIFICATION REFERENCE

UNIFORM STANDARD DRAWINGS
CLARK COUNTY AREA

MISCELLANEOUS SIGNAL
MOUNTING HARDWARE

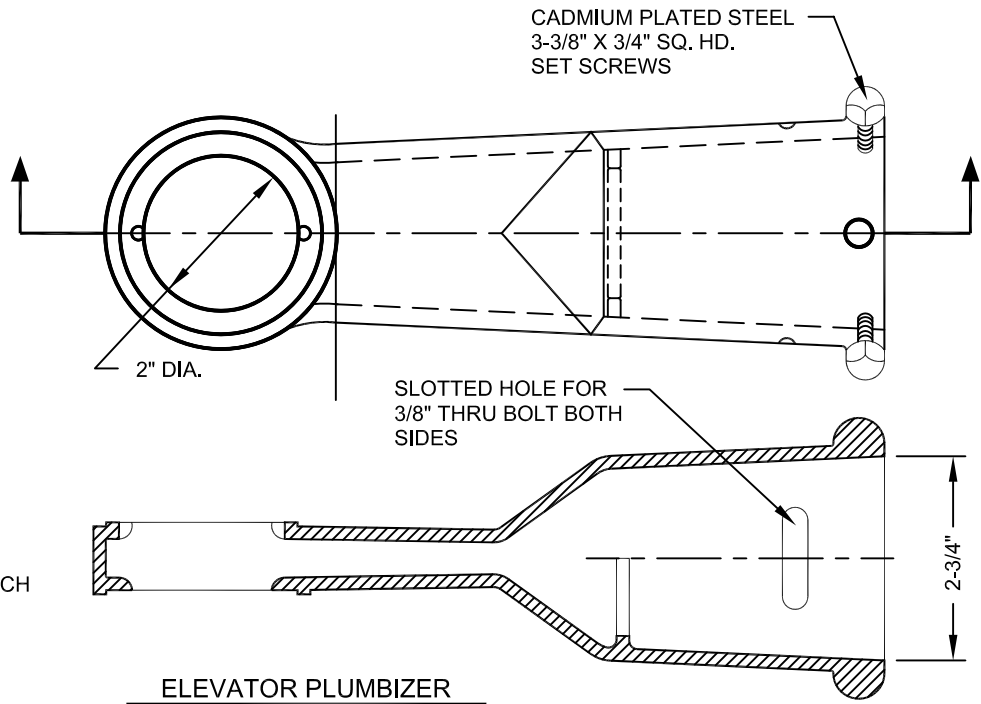

NOTES:

1. MATERIAL - BRONZE
2. PAINT COLOR SHALL MATCH SIGNAL HOUSING

SPECIFICATION REFERENCE

UNIFORM STANDARD DRAWINGS
CLARK COUNTY AREA

ELEVATOR PLUMBIZER

DATE

DWG. NO.

404.1203

SHEET

1 OF 1

NOTES:

1. MATERIAL-BRONZE
2. PAINT COLOR SHALL MATCH SIGNAL HOUSING.
3. PROVIDE WASHERS SHOWN AND 1/2" PLATED BOLTS, LENGTH FOR STEEL POLE MOUNTING.

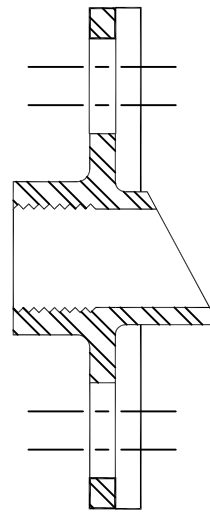
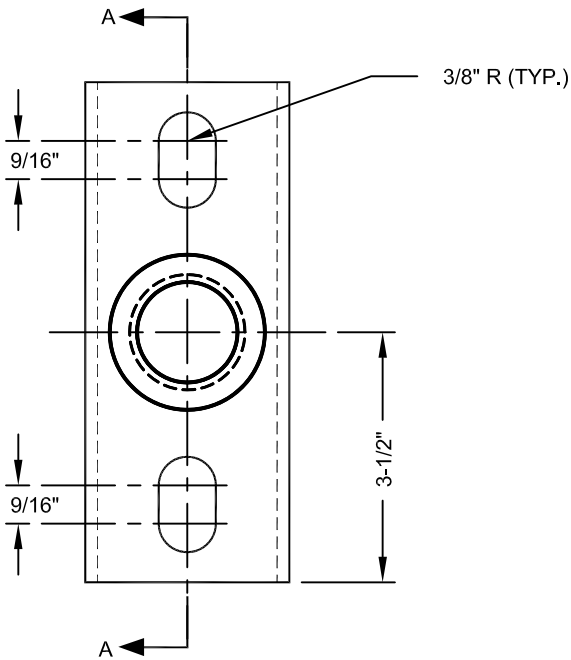
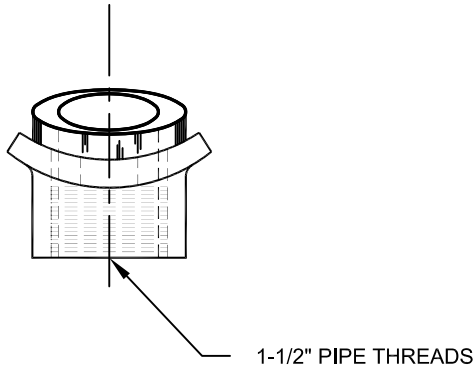

SECTION A-A

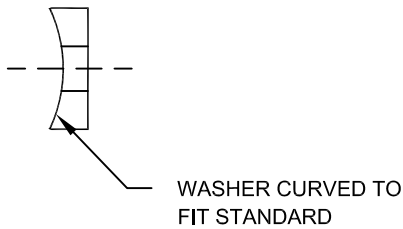
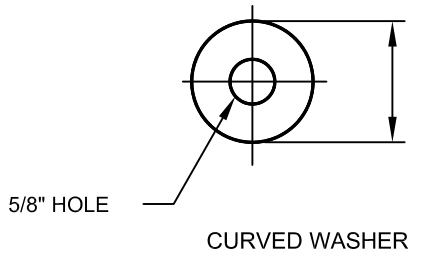

SPECIFICATION REFERENCE

UNIFORM STANDARD DRAWINGS
CLARK COUNTY AREA

POLE PLATE
WITH WIRE GUIDE DETAILS

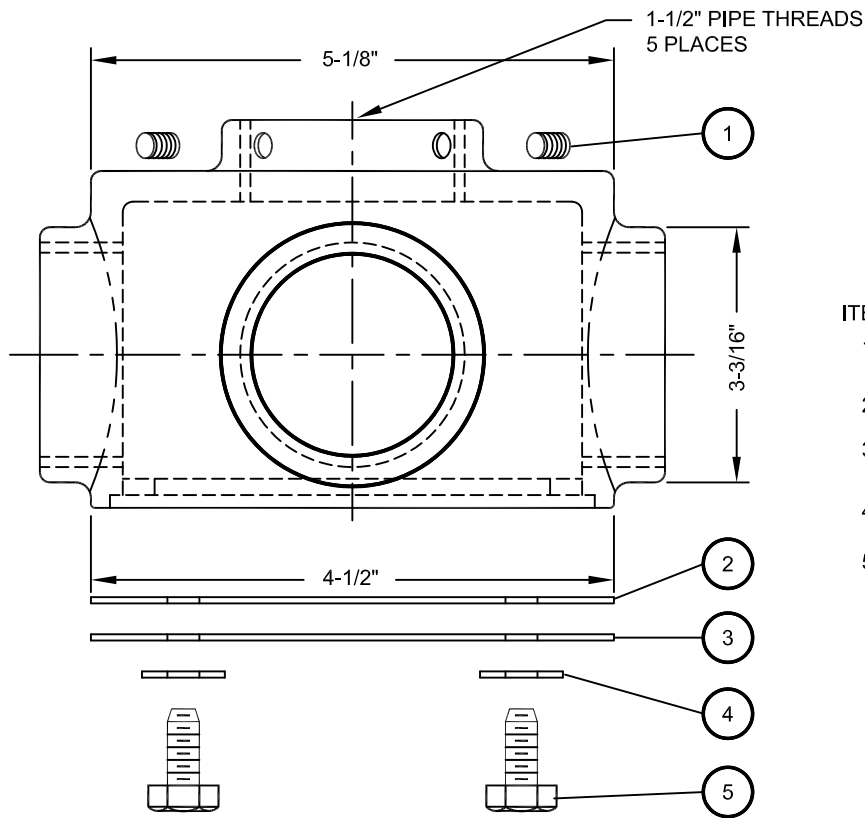

LIST OF MATERIALS

ITEM	QU.	DESCRIPTION
1.	2	1/4" - 20 UNC-2A X 3/8" SOCKET, CUP SET SCREW
2.	1	CORK GASKET TO MATCH COVER
3.	1	3/32" STEEL COVER WITH 2 BOLT HOLES OPPOSITE
4.	2	STANDARD LOCK WASHER
5.	5	3/8" - 16 UNC-2A X 1" BRASS HEX. HD CAP SCREW 2 REQ.

NOTES:

1. PAINT COLOR AND FINISHING SHALL MATCH SIGNAL HOUSING
2. MATERIAL: HIGH STRENGTH CAST ALUMINUM ALLOY

SPECIFICATION REFERENCE

UNIFORM STANDARD DRAWINGS
CLARK COUNTY AREA

4 WAY CENTER HUB

DATE	DWG. NO.	404.1205	SHEET	1 OF 1
------	----------	----------	-------	--------

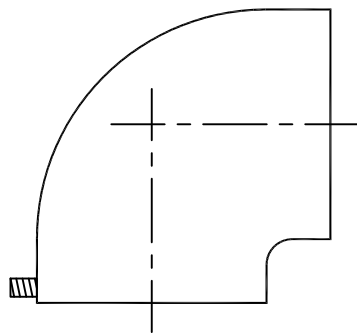

ELBOW

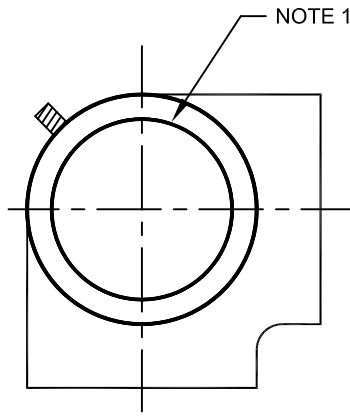

ELBOW WITH
SIDE OUTLET

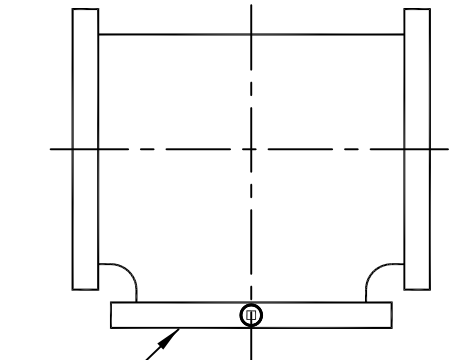

TEE

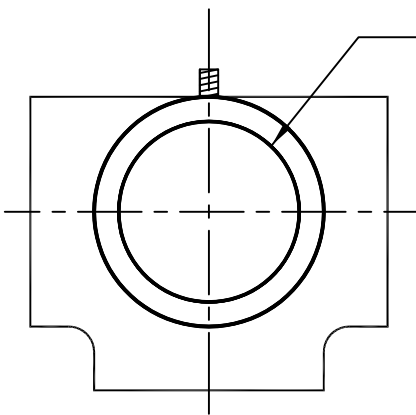

TEE WITH
SIDE OUTLET

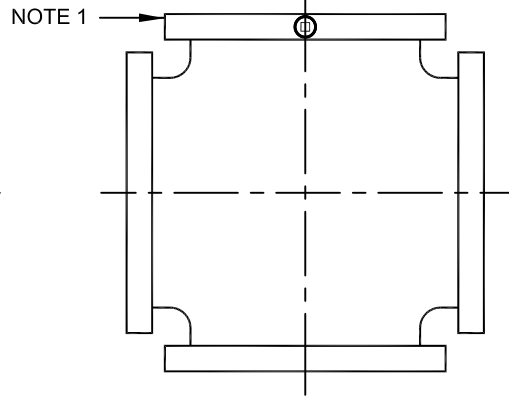

CROSS

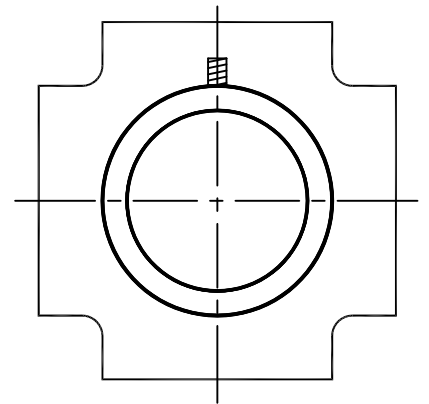

CROSS WITH
SIDE OUTLET

NOTES:

1. REAM FOR 1-1/2" IPS. PROVIDE SET SCREW.
2. ALL OTHER OPENINGS SHALL BE THREADED.
3. PAINT COLOR SHALL MATCH SIGNAL HOUSING.

SPECIFICATION REFERENCE

UNIFORM STANDARD DRAWINGS
CLARK COUNTY AREA

STANDARD MALLEABLE
PIPE HARDWARE- 1-1/2" IPS

DATE	DWG. NO.	404.1206	SHEET	1 OF 1
------	----------	----------	-------	--------

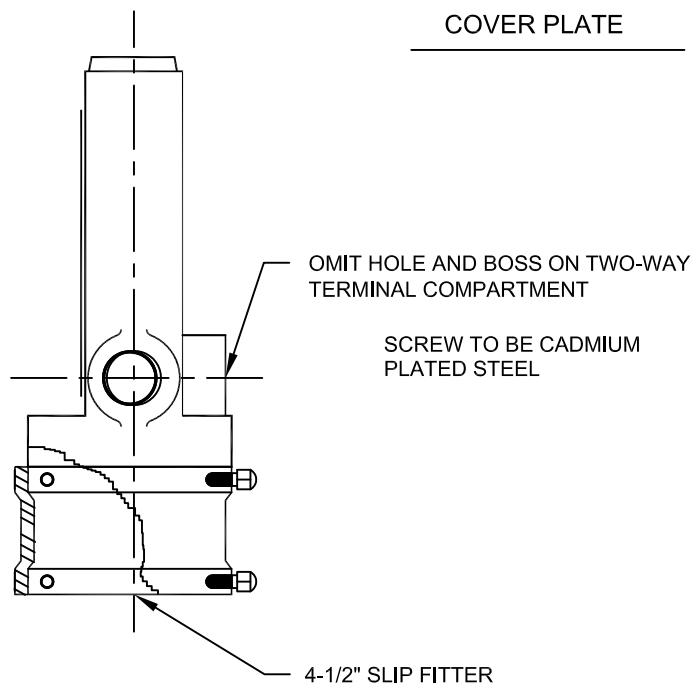
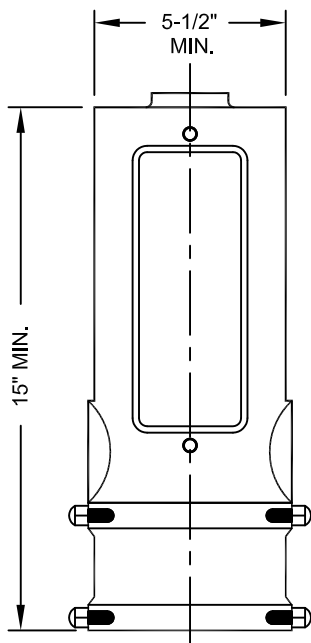
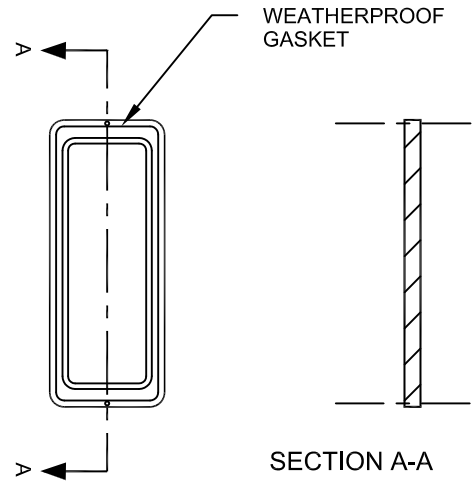
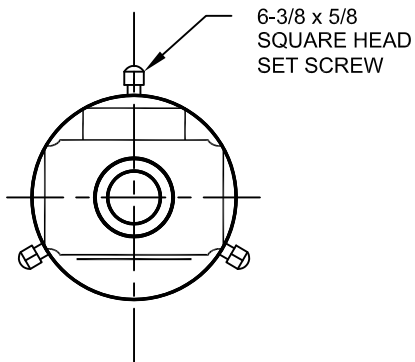

NOTES:

1. MATERIAL - ALUMINUM
2. PAINT COLOR SHALL MATCH SIGNAL HOUSING
3. PROVIDE 12 POSITION PRESSURE TYPE TERMINAL BLOCK MOUNTED INSIDE COMPARTMENT

SPECIFICATION REFERENCE

UNIFORM STANDARD DRAWINGS
CLARK COUNTY AREA

POST TOP MOUNTED ADAPTER
WITH TERMINAL COMPARTMENT

DATE	DWG. NO.	404.1207	SHEET	1 OF 1
------	----------	----------	-------	--------

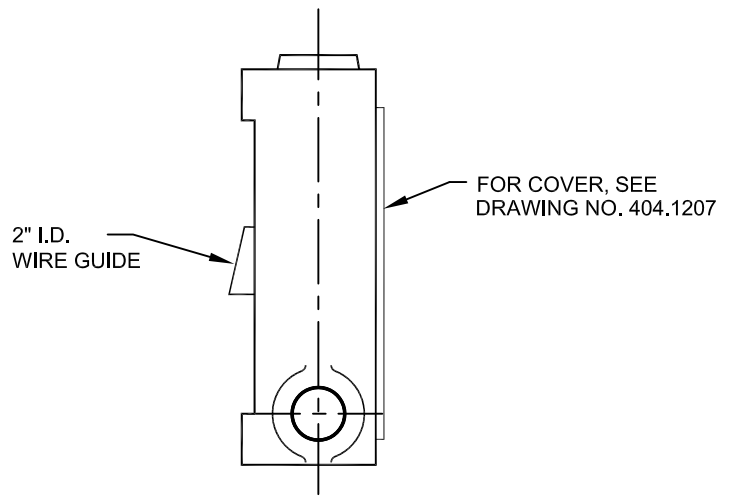
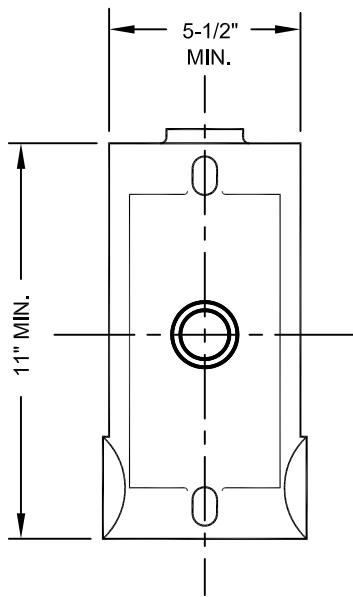
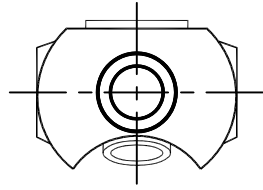

NOTES:

1. MATERIAL - ALUMINUM
2. PAINT COLOR SHALL MATCH SIGNAL HOUSING
3. PROVIDE 12 POSITION PRESSURE TYPE TERMINAL BLOCK MOUNTED INSIDE COMPARTMENT

SPECIFICATION REFERENCE

UNIFORM STANDARD DRAWINGS
CLARK COUNTY AREA

SIDE BRACKET MOUNTED
ADAPTER WITH WIRE GUIDE

DATE

DWG. NO. 404.1208

SHEET

1 OF 1

NOTES:

1. THE DEVICES WILL BE CONSTRUCTED OR CAST IN ACCORDANCE WITH SPECIAL PATENTED DEVICES, MATERIALS, AND PROCESSES.
2. SIGNAL HEAD MOUNT AND FLANGE ADAPTER WILL BE OF HIGH STRENGTH CAST ALUMINUM.
3. SIGNAL HEAD MOUNT SHALL BE FASTENED TO FLANGE ADAPTER BY MEANS OF FOUR COMMON STRUCTURAL STEEL BOLTS PER SPEC. EACH WITH TWO FLAT WASHERS, LOCK WASHER AND NUT.
4. ALL BOLTS, NUTS, AND WASHERS REQUIRED SHALL BE AS REGULARLY SUPPLIED BY THE MANUFACTURER.
5. ONE-WAY MOUNT SHALL BE USED WHEN PLANS OR SPECIAL PROVISIONS CALL FOR ONE-WAY SIGNAL MOUNTED ON SIGNAL MAST ARM.
6. TWO-WAY MOUNT SHALL BE USED WHEN PLANS OR SPECIAL PROVISIONS CALL FOR TWO-WAY SIGNAL MOUNTED ON SIGNAL MAST ARM.
7. TWO SIGNAL INDICATIONS SHALL BE MOUNTED BELOW THE MOUNT AND ALL REMAINING SIGNAL INDICATIONS MOUNTED ABOVE.

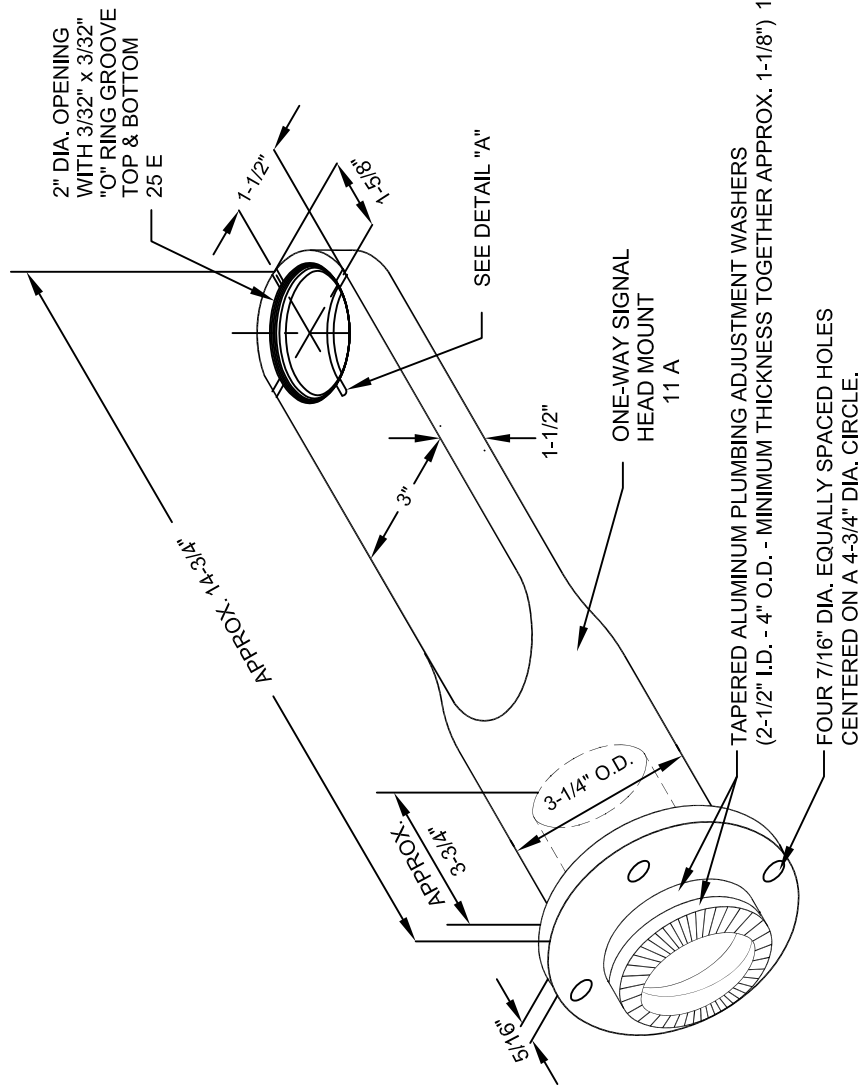

ONE-WAY MOUNT
32 A

SPECIFICATION REFERENCE

UNIFORM STANDARD DRAWINGS
CLARK COUNTY AREA

ONE WAY
MOUNT

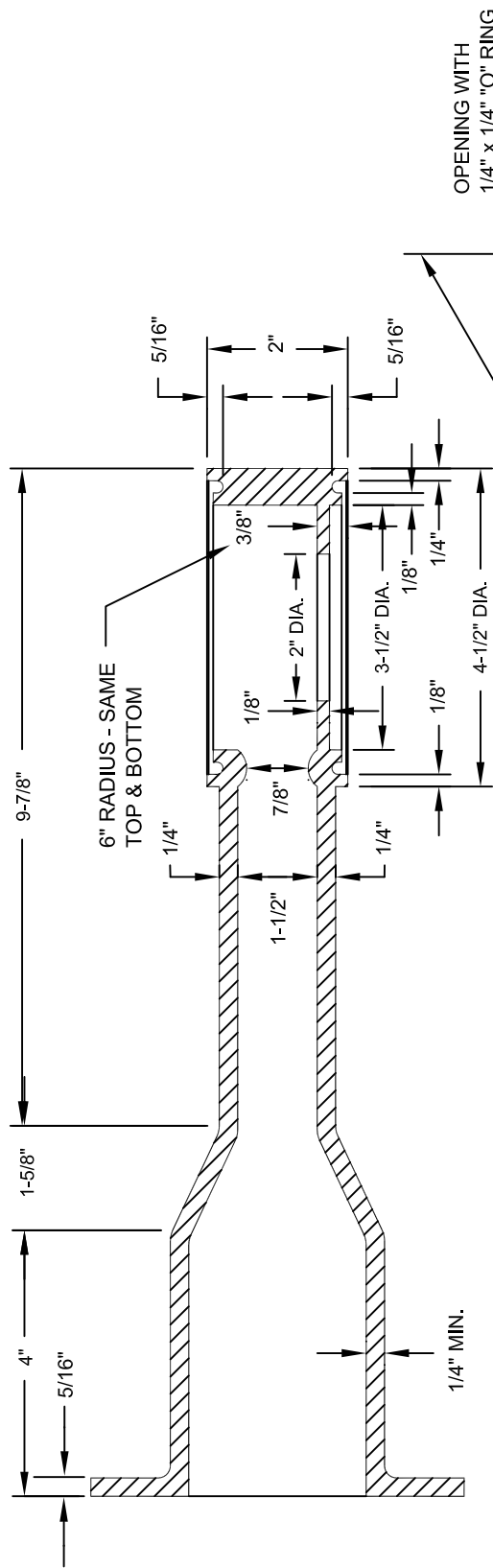

SECTION THROUGH ONE-WAY MOUNT FOR 3M SIGNALS

NOTES:

1. THE DEVICES WILL BE CONSTRUCTED OR CAST IN ACCORDANCE WITH SPECIAL PATENTED DEVICES, MATERIALS, AND PROCESSES.
2. SIGNAL HEAD MOUNT AND FLANGE ADAPTER WILL BE OF HIGH STRENGTH CAST ALUMINUM.
3. SIGNAL HEAD MOUNT SHALL BE FASTENED TO FLANGE ADAPTER BY MEANS OF FOUR COMMON STRUCTURAL STEEL BOLTS PER SPEC. EACH WITH TWO FLAT WASHERS, LOCK WASHER AND NUT.
4. ALL BOLTS, NUTS, AND WASHERS REQUIRED SHALL BE AS REGULARLY SUPPLIED BY THE MANUFACTURER.
5. ONE-WAY MOUNT SHALL BE USED WHEN PLANS OR SPECIAL PROVISIONS CALL FOR ONE-WAY SIGNAL MOUNTED ON SIGNAL MAST ARM.
6. TWO-WAY MOUNT SHALL BE USED WHEN PLANS OR SPECIAL PROVISIONS CALL FOR TWO-WAY SIGNAL MOUNTED ON SIGNAL MAST ARM.
7. TWO SIGNAL INDICATIONS SHALL BE MOUNTED BELOW THE MOUNT AND ALL REMAINING SIGNAL INDICATIONS MOUNTED ABOVE.

APPROX. 15-1/2"

APPROX. 3-3/4"

3-1/4" O.D.

5/16"

1-1/2"

2-1/4"

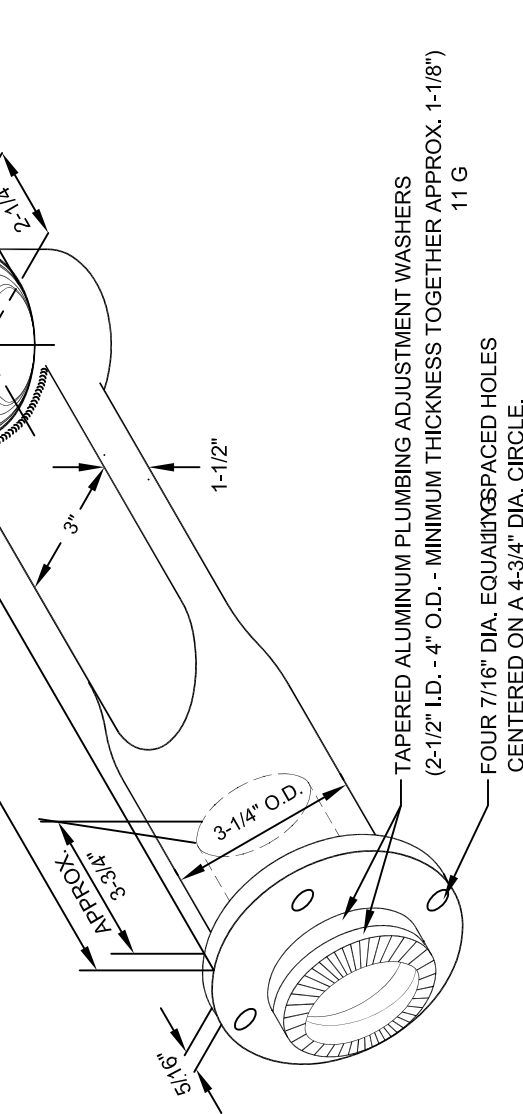

ONE-WAY MOUNT FOR 3M SIGNALS
32 H

SPECIFICATION REFERENCE	

UNIFORM STANDARD DRAWINGS CLARK COUNTY AREA			
ONE WAY MOUNT FOR 3M SIGNALS			
DATE	DWG. NO.	404.1211	SHEET 1 OF 1

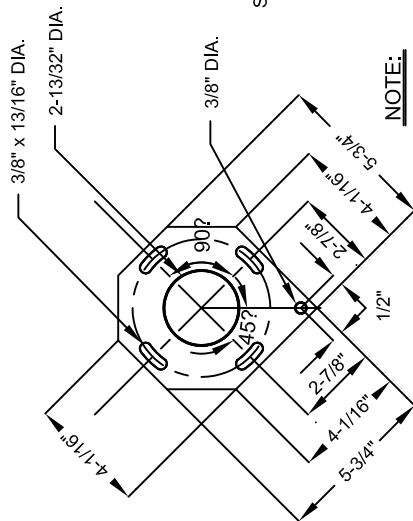

NOTE:

FLANGE TO BE WELDED TO MAST ARM SLIPFITTER 4" FROM THE END.

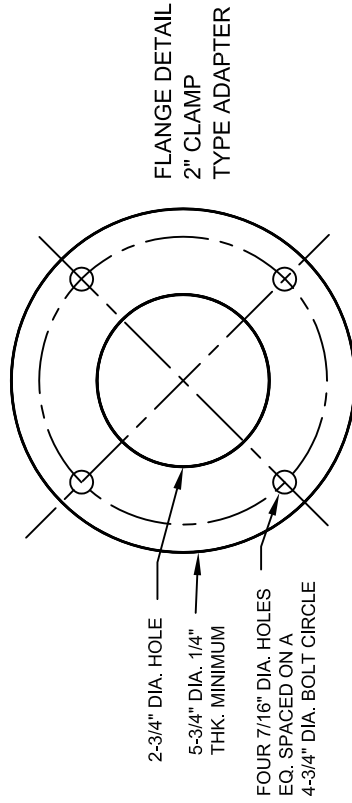
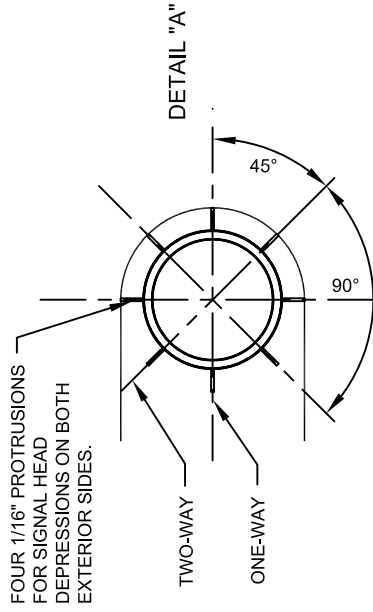
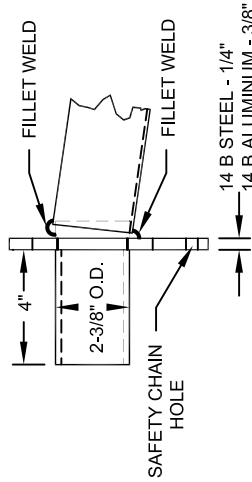

FLANGE DETAIL
2" WELDED TYPE ADAPTER

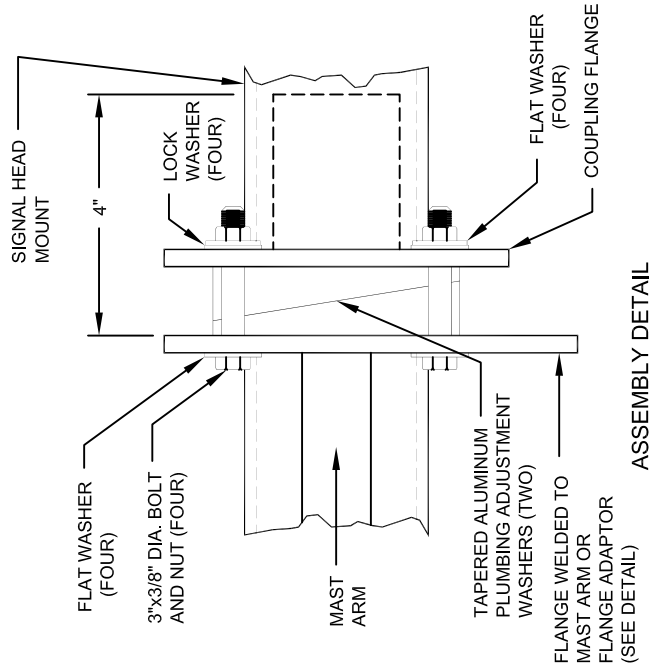

ASSEMBLY DETAIL

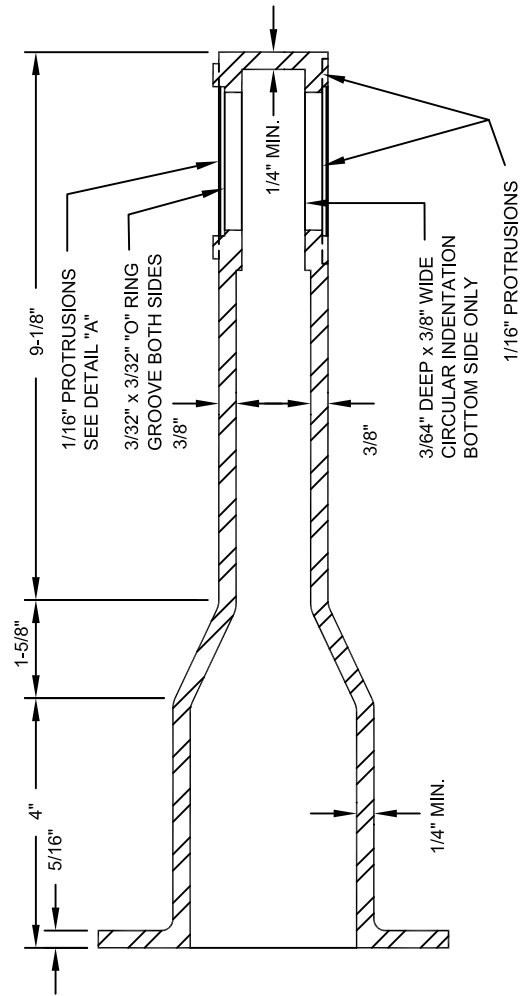

SECTION THROUGH ONE-WAY MOUNT

SPECIFICATION REFERENCE

UNIFORM STANDARD DRAWINGS
CLARK COUNTY AREA

ONE WAY MOUNT
DETAIL

DATE

DWG. NO.

404.1212

SHEET

1 OF 1

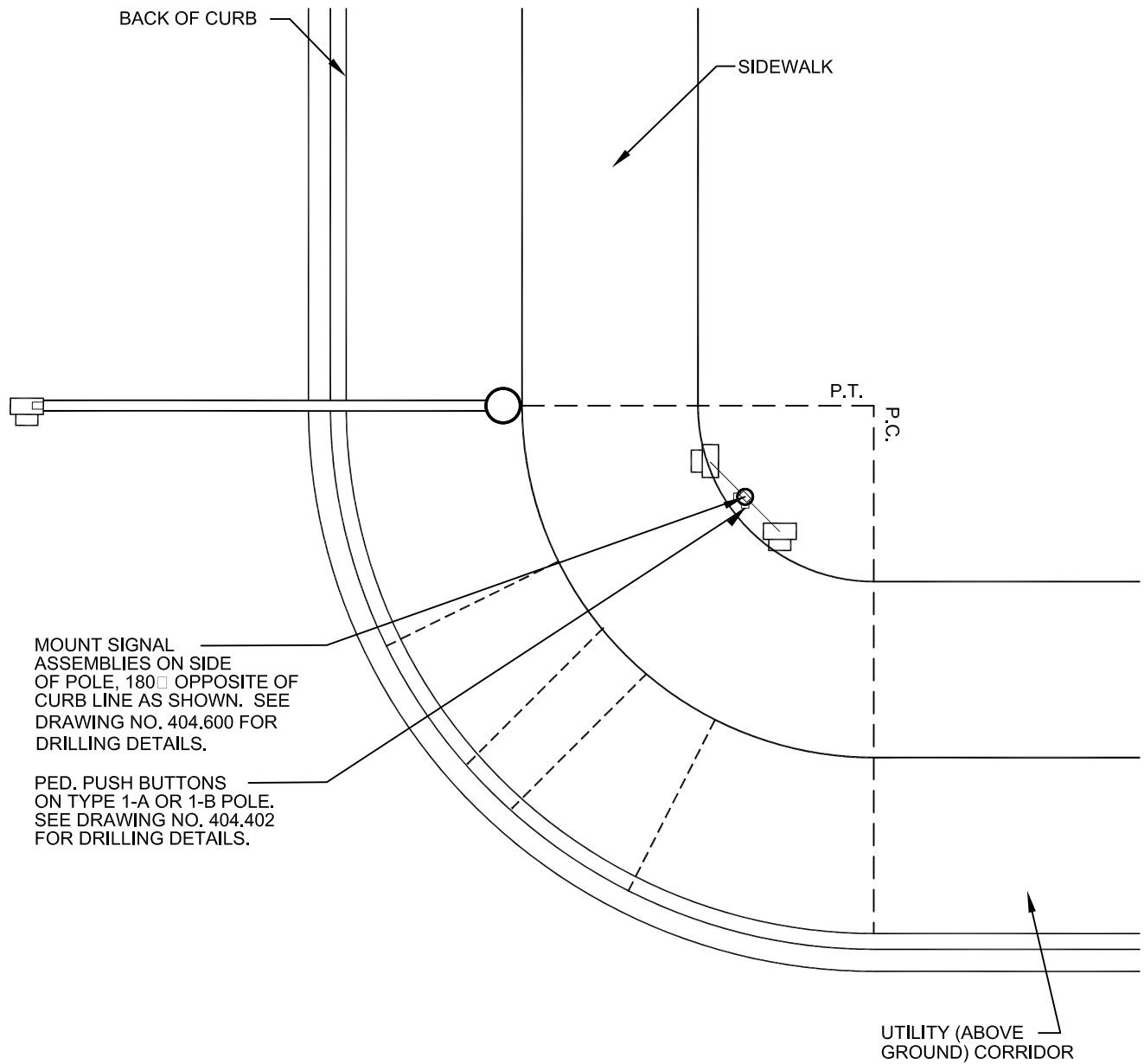

NOTE:

1. ALTERNATE LOCATIONS FOR THE POLES MAY BE APPROVED BY THE AGENCY'S TRAFFIC ENGINEER.

SPECIFICATION REFERENCE

UNIFORM STANDARD DRAWINGS
CLARK COUNTY AREA

POLE LOCATION & SIGNAL
MOUNTING AT INTERSECTION
(TWO POLE)
OFFSET SIDEWALK

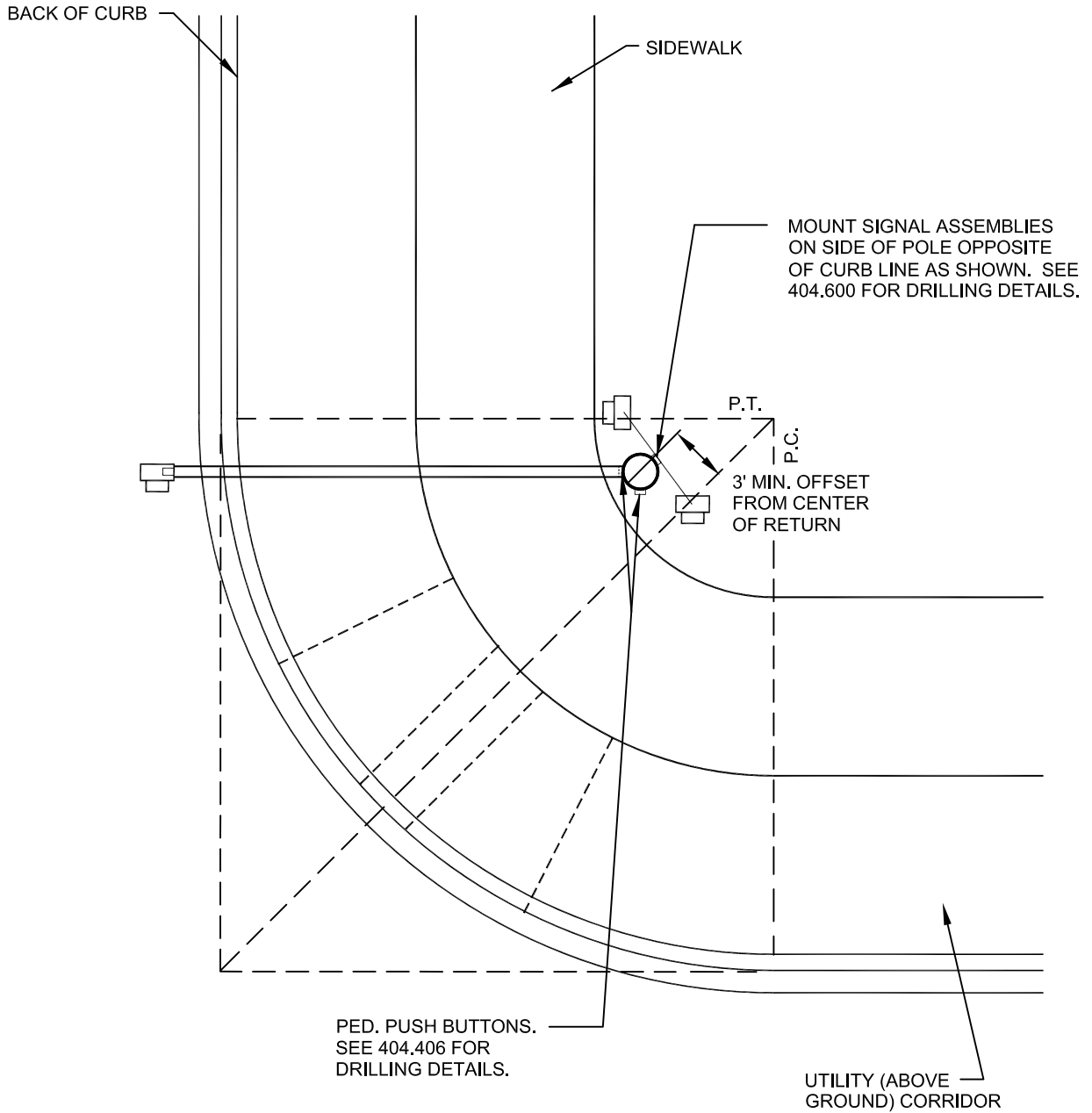

NOTE:

1. ALTERNATE LOCATIONS FOR THE SIGNAL POLE MAY BE APPROVED BY THE AGENCY'S TRAFFIC ENGINEER.

SPECIFICATION REFERENCE

UNIFORM STANDARD DRAWINGS
CLARK COUNTY AREA

POLE LOCATION & SIGNAL
MOUNTING AT INTERSECTION
(SINGLE POLE)
OFFSET SIDEWALK

DATE 7-10-03 | DWG. NO. 404.1300 ALT | SHEET 2 OF 2

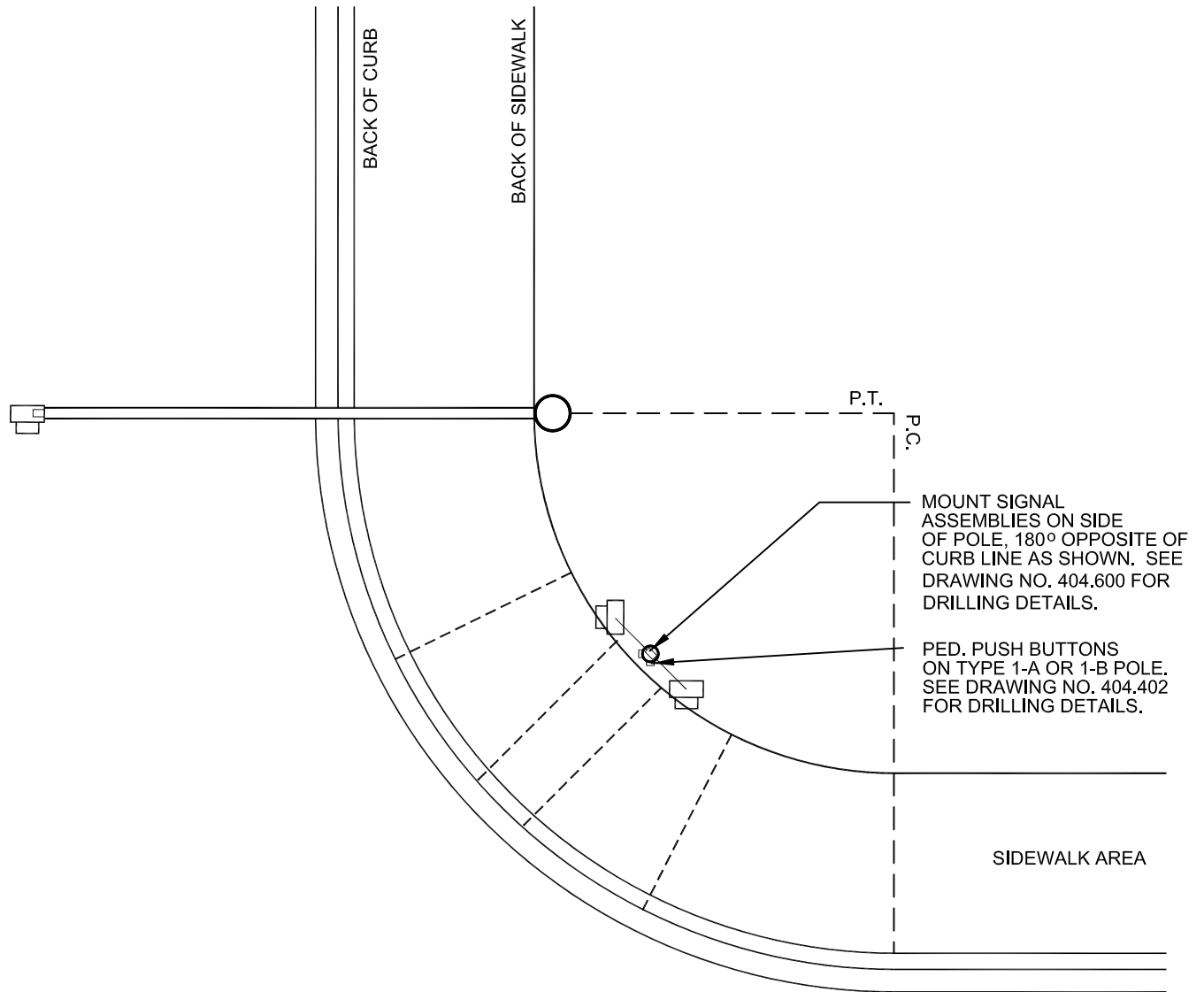

NOTE:

1. ALTERNATE LOCATIONS FOR THE POLES MAY BE APPROVED BY THE AGENCY'S TRAFFIC ENGINEER.

SPECIFICATION REFERENCE

UNIFORM STANDARD DRAWINGS
CLARK COUNTY AREA

POLE LOCATION & SIGNAL
MOUNTING AT INTERSECTION
(TWO POLE)
CURBSIDE SIDEWALK

DATE 7-10-03 | DWG. NO. 404.1300 | SHEET 1 OF 2

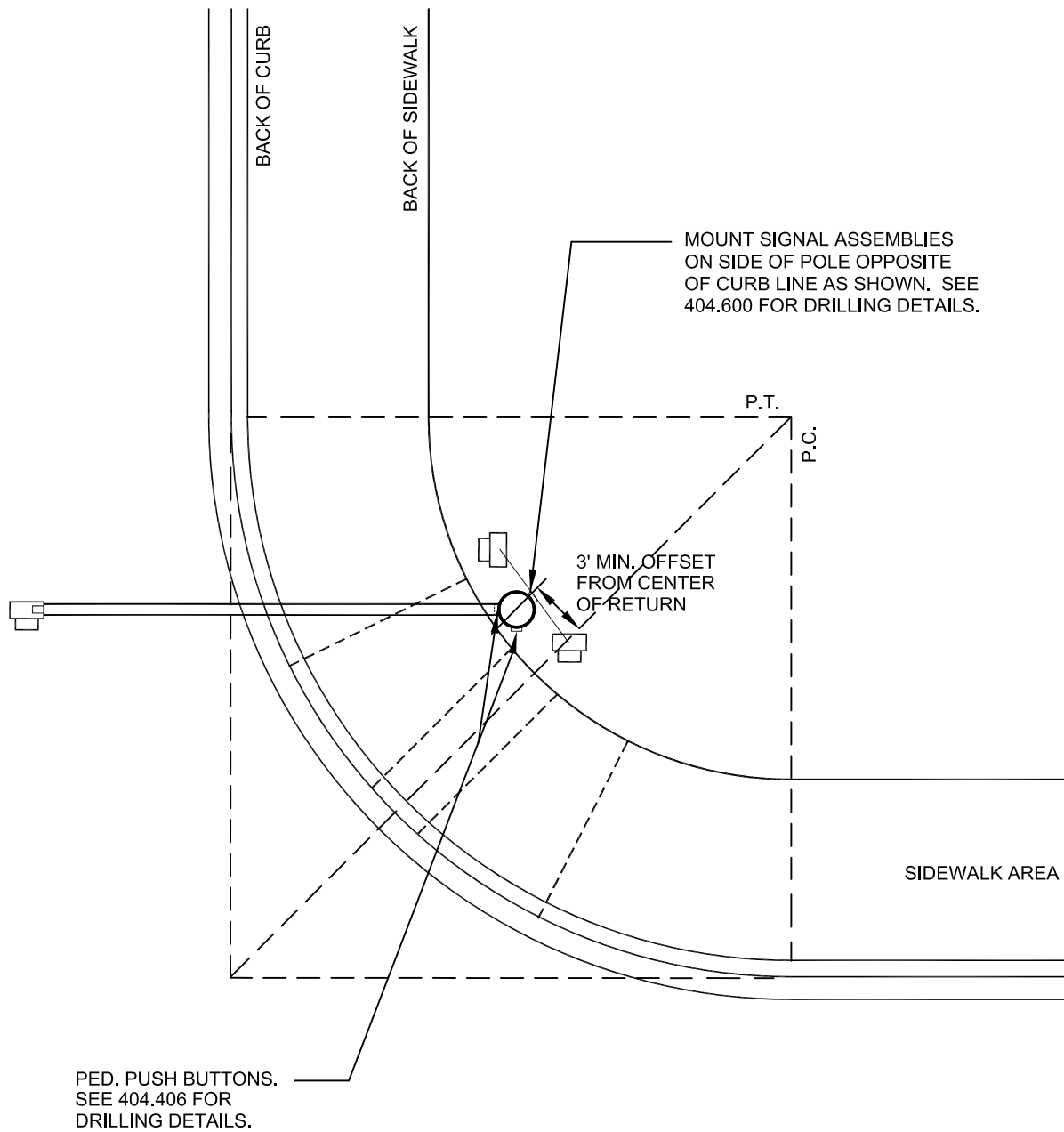

NOTE:

1. ALTERNATE LOCATIONS FOR THE SIGNAL POLE MAY BE APPROVED BY THE AGENCY'S TRAFFIC ENGINEER.

SPECIFICATION REFERENCE		UNIFORM STANDARD DRAWINGS CLARK COUNTY AREA			
		POLE LOCATION & SIGNAL MOUNTING AT INTERSECTION (SINGLE POLE) CURBSIDE SIDEWALK			
		DATE 7-10-03	DWG. NO. 404.1300	SHEET	2 OF 2

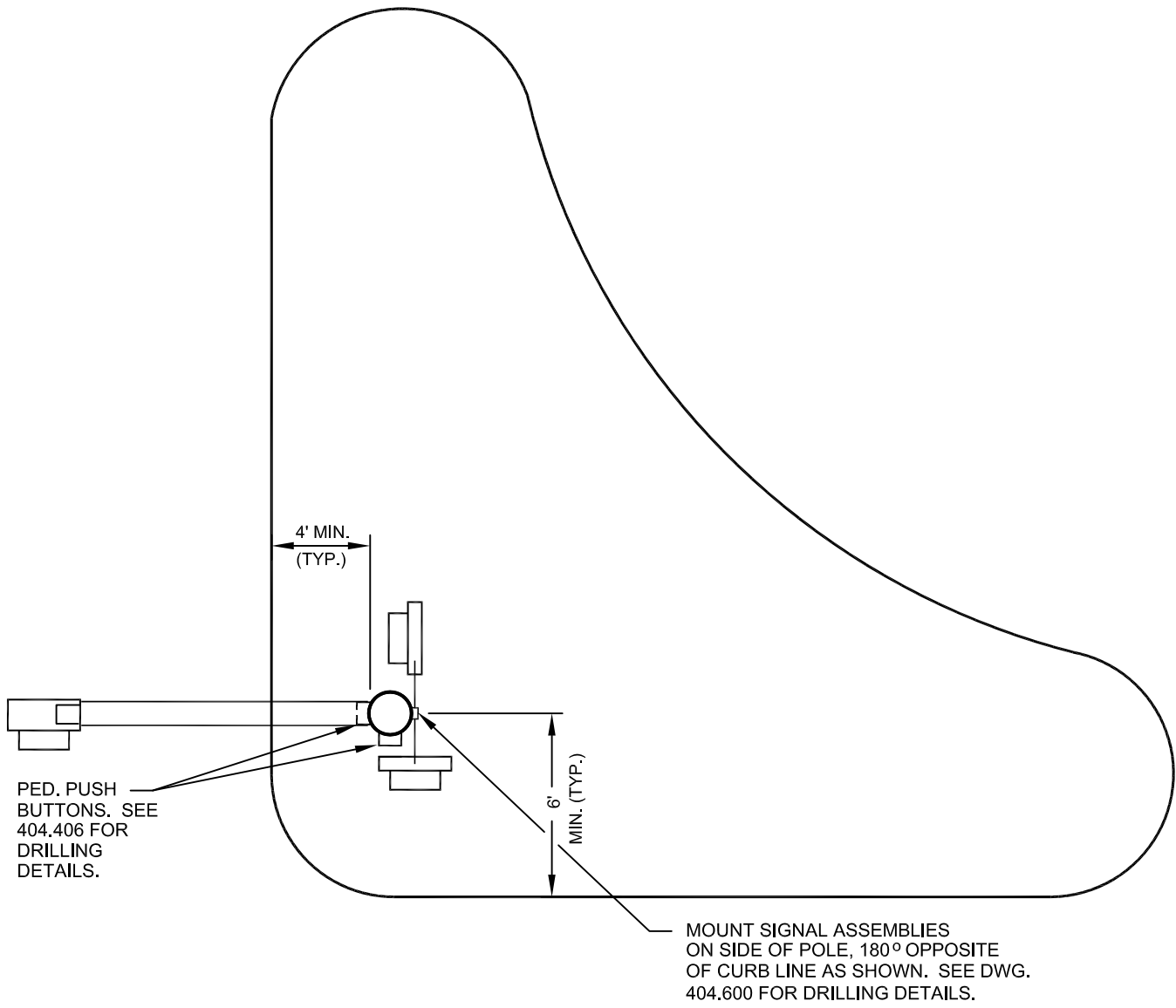

NOTE:

SIDEWALK RAMPS IN ACCORDANCE WITH DRAWING NO. 235 SHALL BE CONSTRUCTED. HANDICAPPED ACCESS MUST BE IN COMPLIANCE WITH THE AMERICANS WITH DISABILITIES ACT (ADA).

SPECIFICATION REFERENCE

UNIFORM STANDARD DRAWINGS
CLARK COUNTY AREA

POLE LOCATION AND SIGNALS
MOUNTING ON RIGHT TURN ISLANDS

DATE	12-12-96	DWG. NO.	404.1301	SHEET	1 OF 1
------	----------	----------	----------	-------	--------

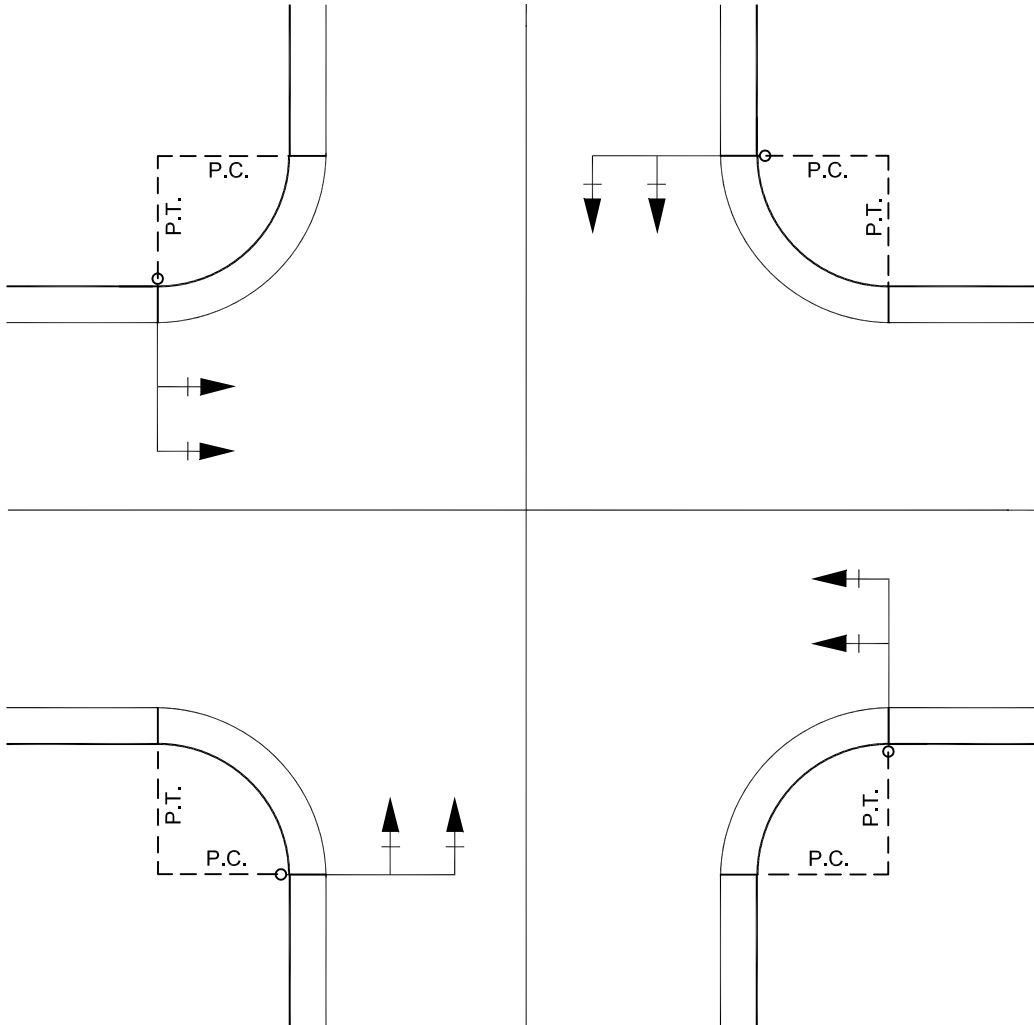

NOTE:

1. SEE PLANS FOR FOUNDATION TYPE.

SPECIFICATION REFERENCE

UNIFORM STANDARD DRAWINGS
CLARK COUNTY AREA

FUTURE POLE LOCATION
CASE I
(EXCEPT CITY OF LAS VEGAS)

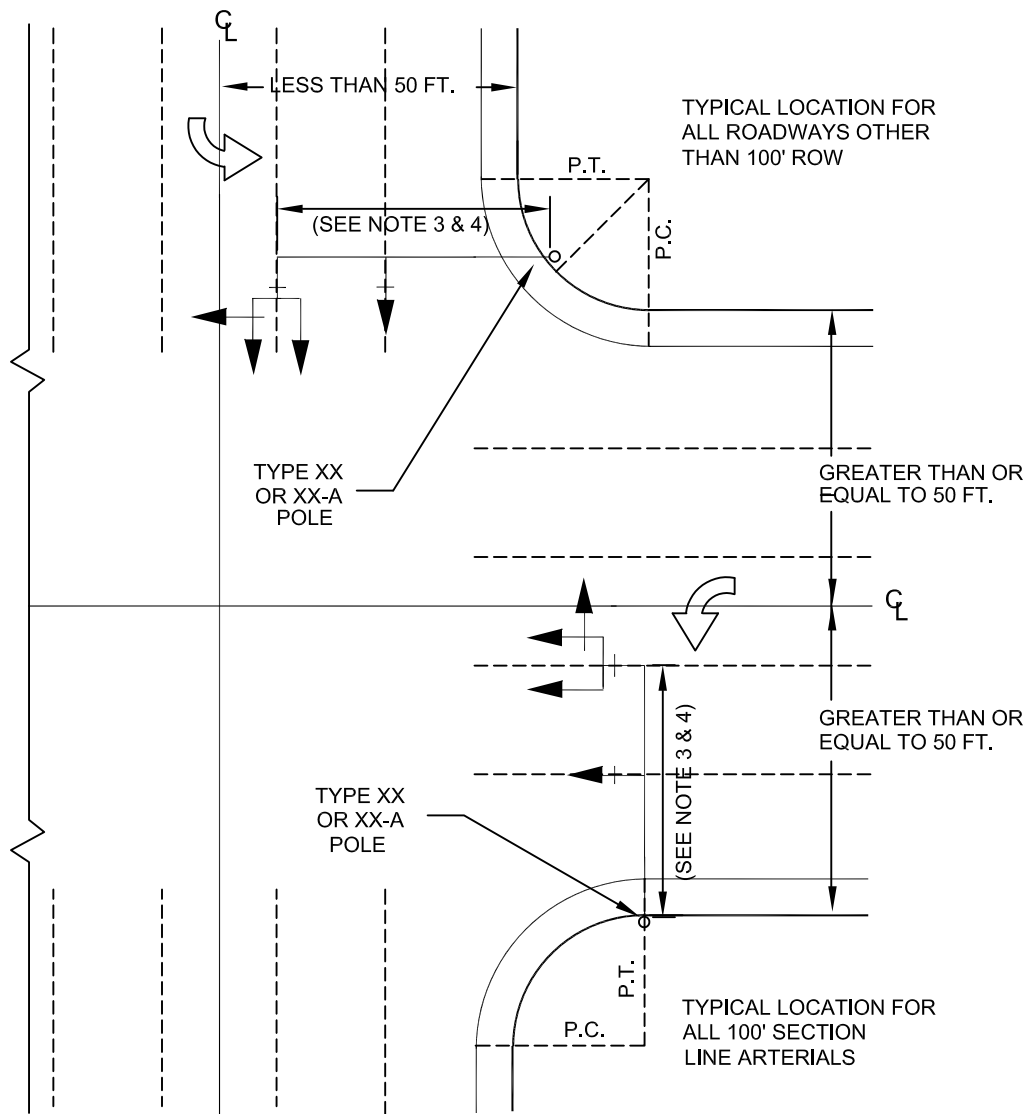

NOTES:

1. FOUNDATIONS WILL BE 36" SQUARE OR ROUND AND 12 FT. DEEP. THE AREA SHALL REMAIN ACCESSIBLE FOR THESE FOUNDATIONS.
2. TRAFFIC SIGNAL POLES SHALL REMAIN AT THE MIDDLE OF THE RETURN BEHIND THE SIDEWALK SO THAT THE OUTSIDE SIGNAL HEAD IS DIRECTLY ABOVE THE LEFT TURN LANE.
3. A TYPE "H" OR "L" FOUNDATION IS REQUIRED FOR MAST ARMS 45' OR LESS. SEE DRAWING NO. 404.208.
4. A TYPE "L" FOUNDATION IS REQUIRED FOR MAST ARMS LONGER THAN 45'. SEE DRAWING NO. 404.209.
5. A MINIMUM OF 32" SHALL BE MAINTAINED BETWEEN TRAFFIC SIGNAL POLE FOUNDATION "CRASH CAP" AND THE BACK OF THE CURB FOR WHEELCHAIR CLEARANCE.
6. THE TRAFFIC ENGINEER WILL MAKE THE FINAL DETERMINATION FOR THE LOCATION OF TRAFFIC SIGNAL POLES.

SPECIFICATION REFERENCE

UNIFORM STANDARD DRAWINGS
CLARK COUNTY AREA

FUTURE POLE LOCATION
CASE II

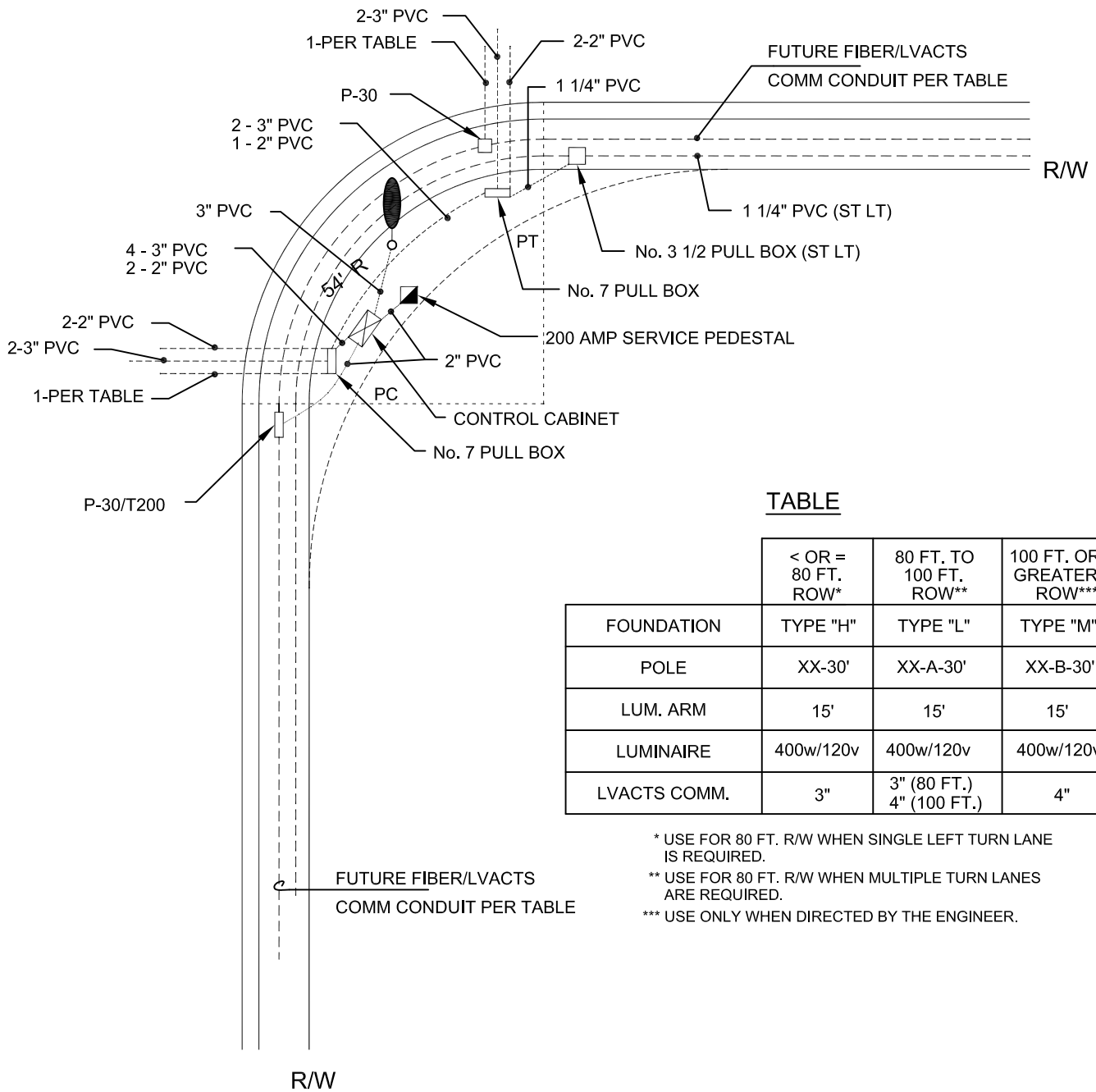

TABLE

	< OR = 80 FT. ROW*	80 FT. TO 100 FT. ROW**	100 FT. OR GREATER ROW***
FOUNDATION	TYPE "H"	TYPE "L"	TYPE "M"
POLE	XX-30'	XX-A-30'	XX-B-30'
LUM. ARM	15'	15'	15'
LUMINAIRE	400w/120v	400w/120v	400w/120v
LVACTS COMM.	3"	3" (80 FT.) 4" (100 FT.)	4"

* USE FOR 80 FT. R/W WHEN SINGLE LEFT TURN LANE IS REQUIRED.
 ** USE FOR 80 FT. R/W WHEN MULTIPLE TURN LANES ARE REQUIRED.
 *** USE ONLY WHEN DIRECTED BY THE ENGINEER.

NOTES:

1. ALL TRAFFIC SIGNAL POLES SHALL BE GALVANIZED PER ASTM A.123.
2. ELECTRIC UTILITY TO SHOW FEEDER TO SERVICE PEDESTAL.
3. FOR POLE, POLE FOUNDATION, SERVICE PEDESTAL AND SERVICE PEDESTAL FOUNDATION DETAILS, SEE CLARK COUNTY AREA UNIFORM STANDARD DRAWINGS.
4. EXTEND THE 2-2" PVC, THE 2-3" AND THE 1-PER TABLE PVC SCHEDULE 40, 5 FEET PAST EDGE OF PAVEMENT STUB AND CAP OR CONNECT TO THE EXISTING TRAFFIC SIGNAL CONDUIT.
5. ALL EMPTY CONDUIT WILL CONTAIN A SINGLE No. 8 AWG THW OR BARE COPPER WIRE FOR THE PURPOSE OF LOCATING THE CONDUIT.

SPECIFICATION REFERENCE

UNIFORM STANDARD DRAWINGS
CLARK COUNTY AREA

TYPICAL TRAFFIC SIGNAL UNDERGROUND
LAYOUT WITH INTERIM STREET LIGHTING
AND SERVICE PEDESTAL
(CENTER OF CURVE RADIUS)

Effective 01/01/09 - 06/30/09

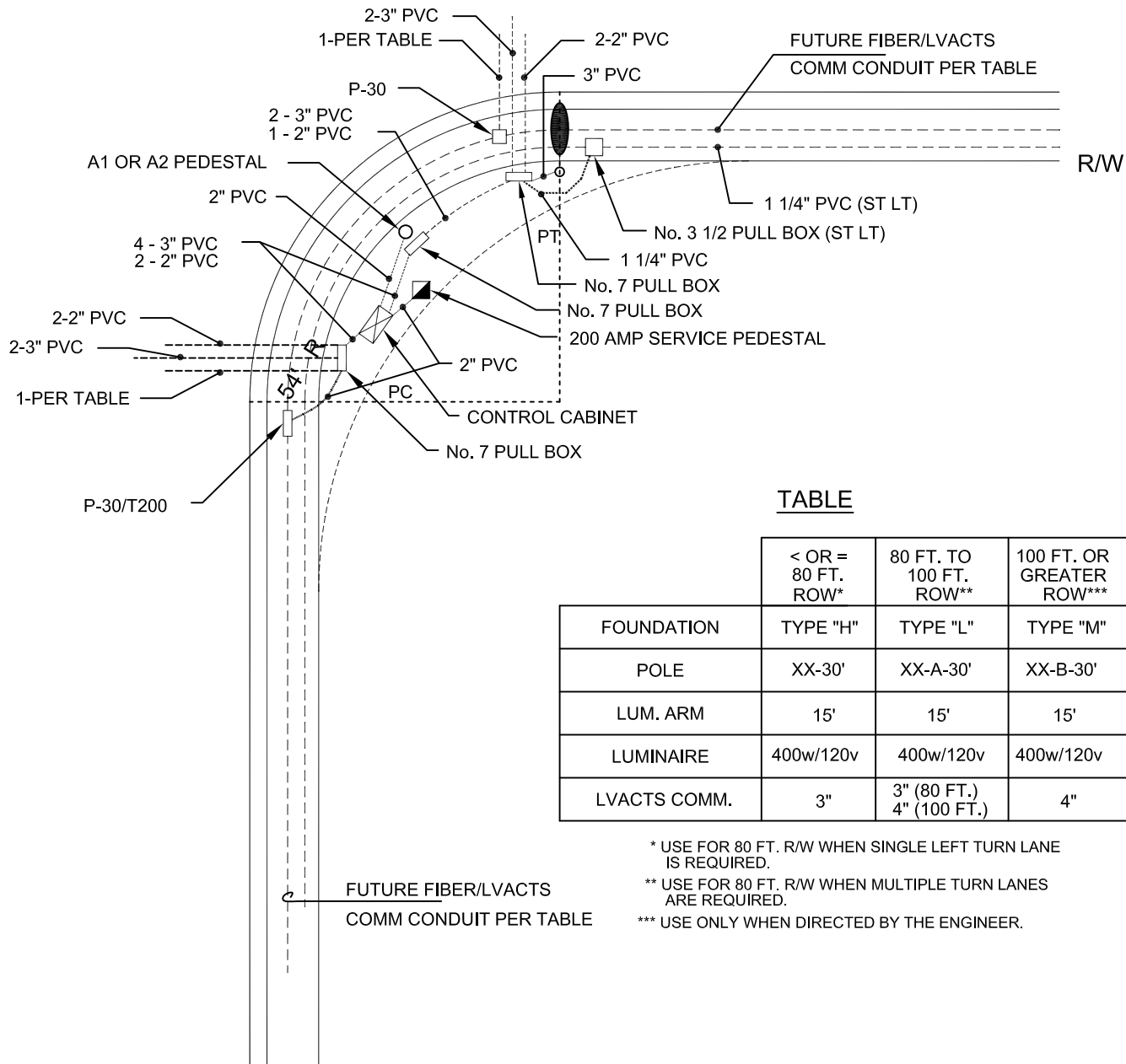

TABLE

	< OR = 80 FT. ROW*	80 FT. TO 100 FT. ROW**	100 FT. OR GREATER ROW***
FOUNDATION	TYPE "H"	TYPE "L"	TYPE "M"
POLE	XX-30'	XX-A-30'	XX-B-30'
LUM. ARM	15'	15'	15'
LUMINAIRE	400w/120v	400w/120v	400w/120v
LVACTS COMM.	3"	3" (80 FT.) 4" (100 FT.)	4"

* USE FOR 80 FT. R/W WHEN SINGLE LEFT TURN LANE IS REQUIRED.
 ** USE FOR 80 FT. R/W WHEN MULTIPLE TURN LANES ARE REQUIRED.
 *** USE ONLY WHEN DIRECTED BY THE ENGINEER.

NOTES:

1. ALL TRAFFIC SIGNAL POLES SHALL BE GALVANIZED PER ASTM A.123.
2. ELECTRIC UTILITY TO SHOW FEEDER TO SERVICE PEDESTAL.
3. FOR POLE, POLE FOUNDATION, SERVICE PEDESTAL AND SERVICE PEDESTAL FOUNDATION DETAILS, SEE CLARK COUNTY AREA UNIFORM STANDARD DRAWINGS.
4. EXTEND THE 2-2" PVC, THE 2-3" AND THE 1-PER TABLE PVC SCHEDULE 40, 5 FEET PAST EDGE OF PAVEMENT STUB AND CAP OR CONNECT TO THE EXISTING TRAFFIC SIGNAL CONDUIT.
5. ALL EMPTY CONDUIT WILL CONTAIN A SINGLE No. 8 AWG THW OR BARE COPPER WIRE FOR THE PURPOSE OF LOCATING THE CONDUIT.

Effective 01/01/09 - 06/30/09

SPECIFICATION REFERENCE	UNIFORM STANDARD DRAWINGS CLARK COUNTY AREA			
	TYPICAL TRAFFIC SIGNAL UNDERGROUND LAYOUT WITH INTERIM STREET LIGHTING AND SERVICE PEDESTAL (END OF CURVE RADIUS)			
	DATE	DWG. NO.	404.1306	SHEET 2 OF 2

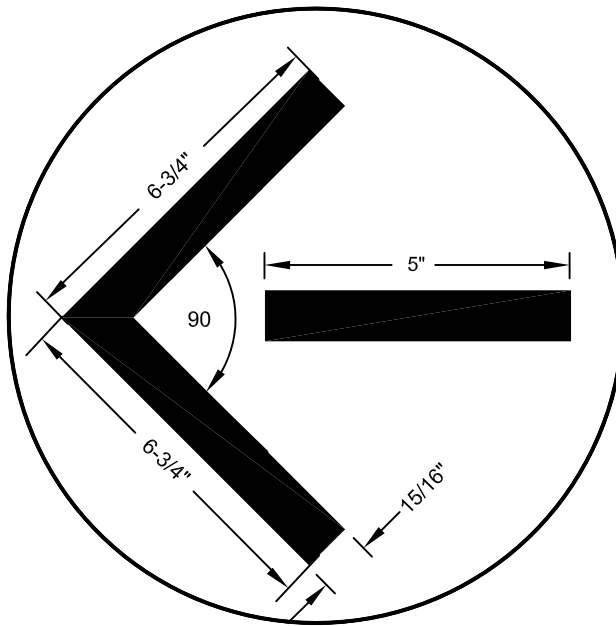
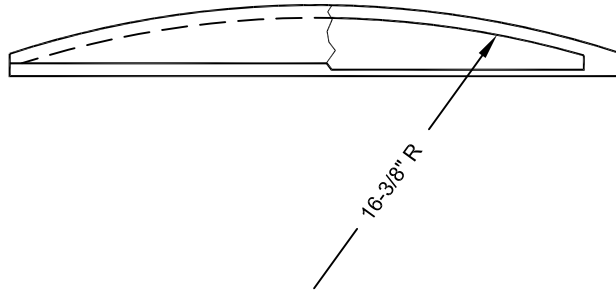

SPECIFICATIONS:

THE ARROW LENS SHALL BE GLASS AND CONFORM TO THE SPECIFICATIONS AS SET FORTH IN TECHNICAL REPORT NO. 1, REVISED 1966, BY THE INSTITUTE OF TRAFFIC ENGINEERS AND APPROVED AS A STANDARD BY THE UNITED STATES OF AMERICA STANDARD INSTITUTE. ANY FUTURE REVISIONS ACCEPTABLE AND ADOPTED BY THE U.S.A.S.I. SHALL AUTOMATICALLY BE PART OF THIS DRAWING SPECIFICATION.

SPECIFICATION REFERENCE

UNIFORM STANDARD DRAWINGS
CLARK COUNTY AREA

12" ARROW
LENS

DATE

DWG. NO.

404.1410

SHEET

1 OF 1

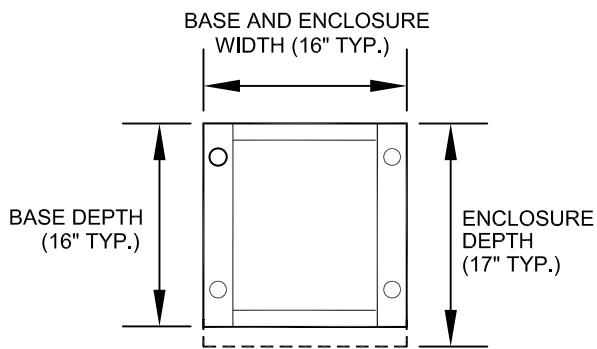
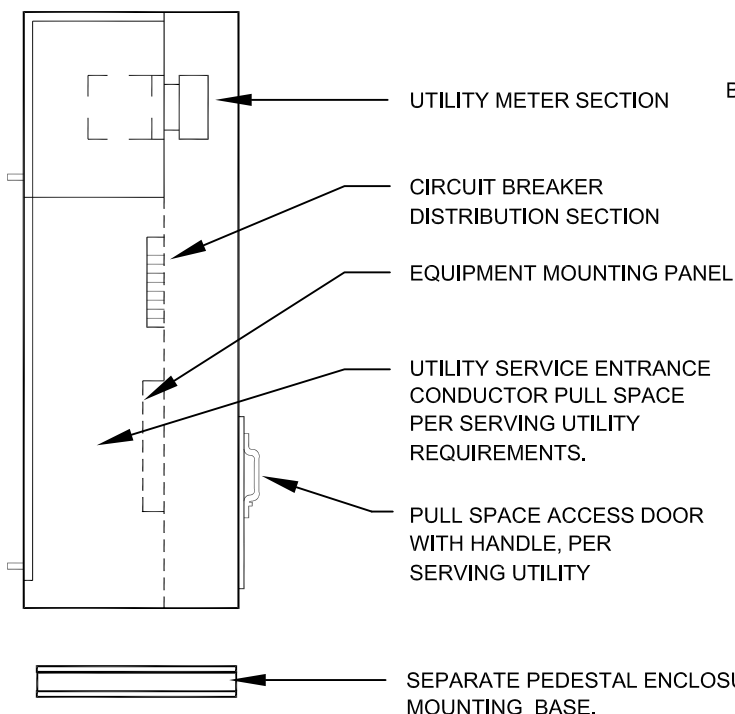
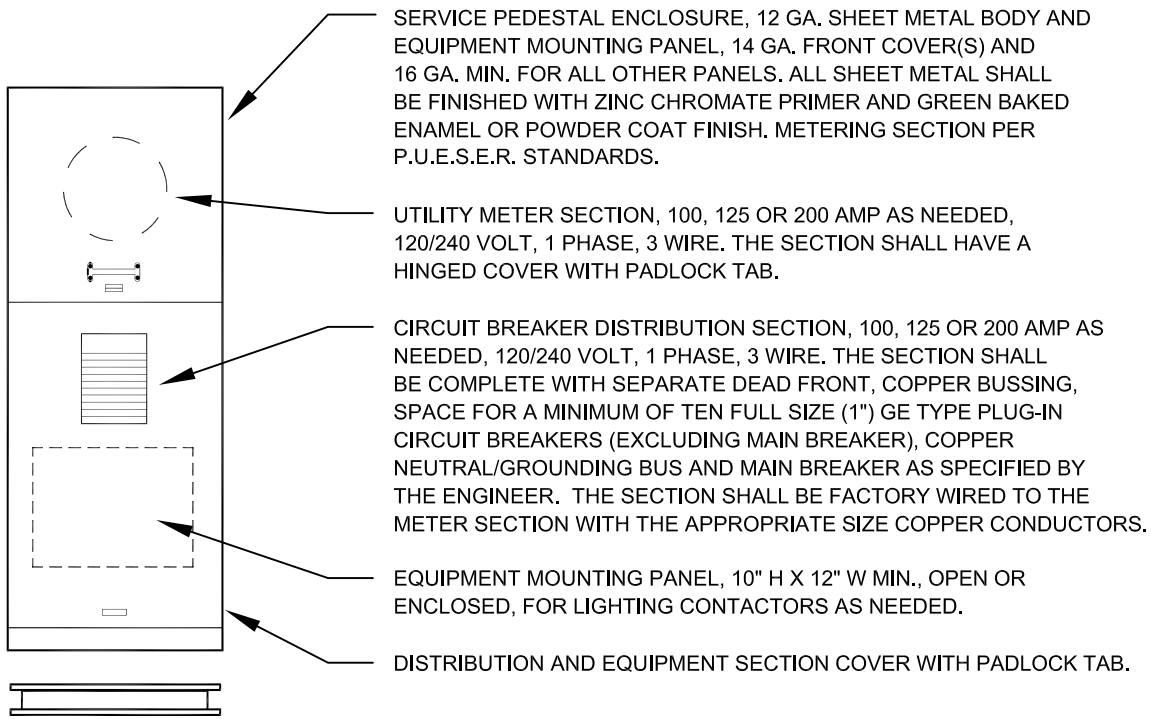

TYPICAL MOUNTING BASE DETAIL
(DIMENSIONS MAY VARY DEPENDING ON MANUFACTURER)

Effective 01/01/09 - 06/30/09

SPECIFICATION REFERENCE		UNIFORM STANDARD DRAWINGS CLARK COUNTY AREA			
506	STEEL STRUCTURES	SINGLE METER SERVICE PEDESTAL			
623	TRAFFIC SIGNALS & STREETLIGHTING				
		DATE 12-12-96	DWG. NO.	404.1412	SHEET 1 OF 1

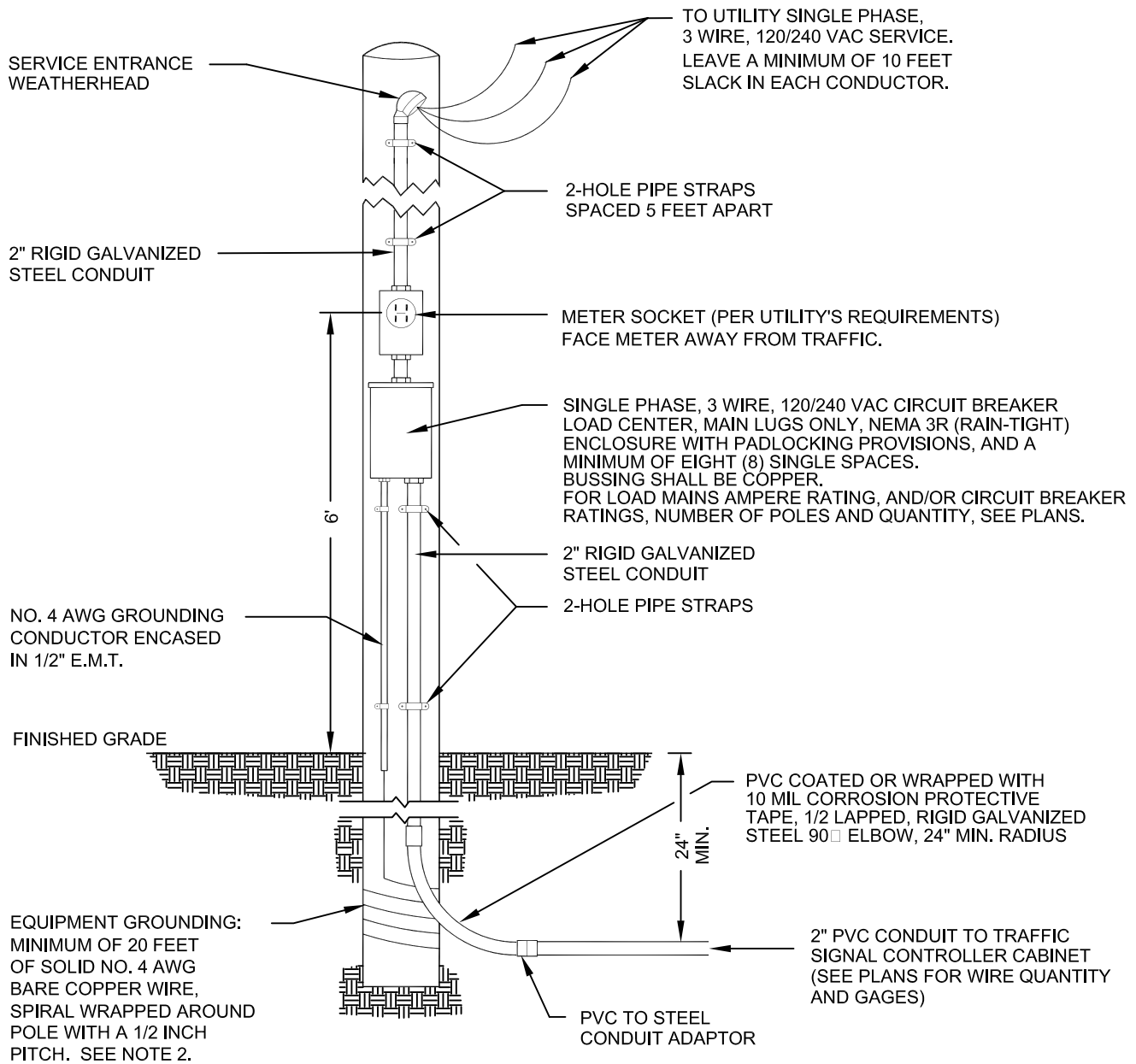

NOTES:

1. ALL WIRES TO BE COPPER; SEE PLANS FOR QUANTITY AND GAGES.
2. WITH ENGINEER'S APPROVAL, AN 8 FT. BY 5/8 IN. COPPER-CLAD GROUNDING ROD MAY BE USED.
3. ALL CONDUIT FITTINGS TO BE WATER-TIGHT.

SPECIFICATION REFERENCE

UNIFORM STANDARD DRAWINGS
CLARK COUNTY AREA

120/240 VAC SERVICE
ON WOOD POLE
OVERHEAD SERVICE

NOTE:

THERMOSTAT,
FAN WIRING,
AND TERMINAL
BLOCK CONN-
ECTIONS NOT
SHOWN.

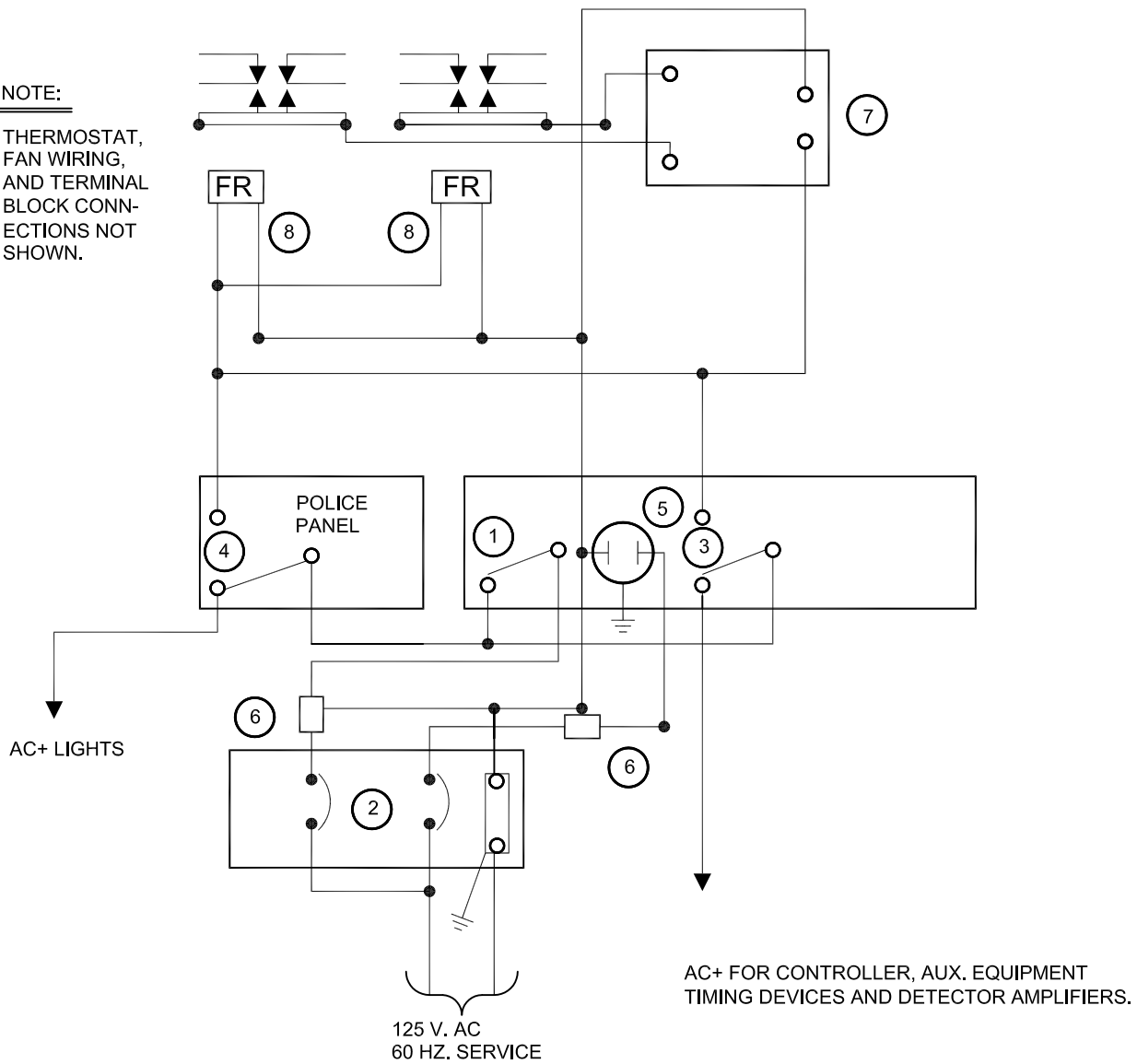

NOTES:

1. MAIN SWITCH.
2. 30 AMP CIRCUIT BREAKERS.
3. SIGNAL FLASH SWITCH INSIDE CABINET.
4. AUXILARY DOOR SIGNAL FLASH SWITCH.
5. NEMA STD. PLUG RECEPTACLE WITH GROUNDING CONTACT.
6. RADIO FREQUENCY INTERFERENCE SUPPRESSOR.
7. SOLID STATE SIGNAL FLASHER (CABINET MFR. TO DETERMINE POLES AND CAPACITY, UNLESS OTHERWISE SPECIFIED)
8. SIGNAL FLASHING CONTROL RELAYS.

SPECIFICATION REFERENCE

UNIFORM STANDARD DRAWINGS
CLARK COUNTY AREA

AUXILIARY CABINET
EQUIPMENT WIRING

OPEN TRENCH

LIP OF GUTTER

PULL BOX (SIZE SPECIFIED ON PLANS)

END OF CONDUIT SHALL BE FITTED WITH BUSHINGS

36" MIN. RADIUS - USE ONLY 20 MIL OR THICKER PVC COATED RIGID IRON CONDUIT FOR BEND AREA. SEE SPECIFICATIONS.

EXCAVATE UNDER EXISTING CURB & GUTTER DO NOT REMOVE C & G.

CONNECTOR

CONTINUE CONDUIT RUN WITH A MINIMUM OF 5 FT. OF PVC COATED R.I.C. SEE CLARK COUNTY AREA SPECS.

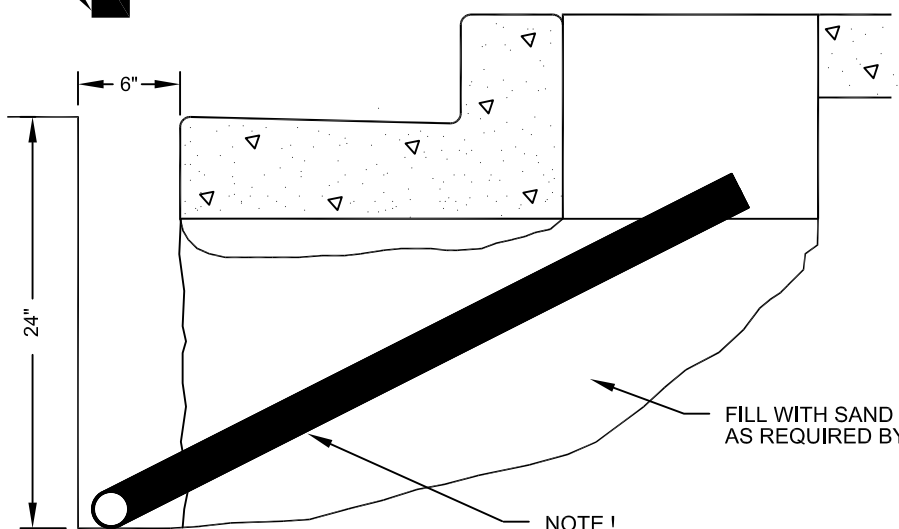

FILL WITH SAND AND COMPACT AS REQUIRED BY FIELD ENGINEER

NOTE!
DO NOT MAKE COMPOUND BENDS IN CONDUIT

SPECIFICATION REFERENCE

UNIFORM STANDARD DRAWINGS
CLARK COUNTY AREA

INSTALLATION OF CONDUIT
INTO PULL BOX FROM LIP
OF GUTTER TRENCH

DATE

DWG. NO.

404.1418

SHEET

1 OF 1

THE CONTRACTOR SHALL USE PVC COATED RIGID IRON CONDUIT CONFORMING TO SPECIFICATIONS.

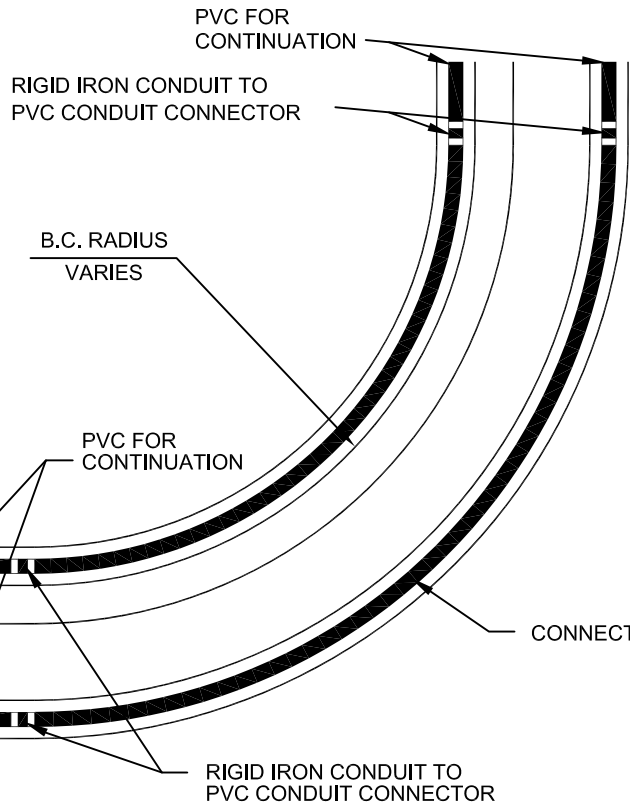

TYPICAL CONDUIT LOCATIONS

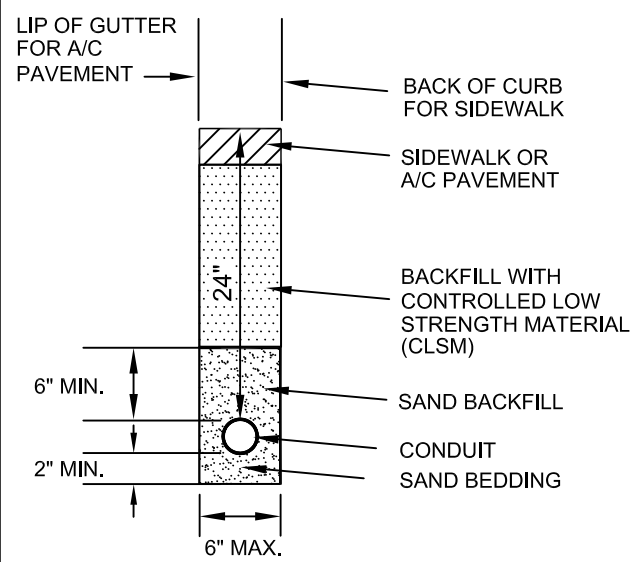

NEW CONSTRUCTION

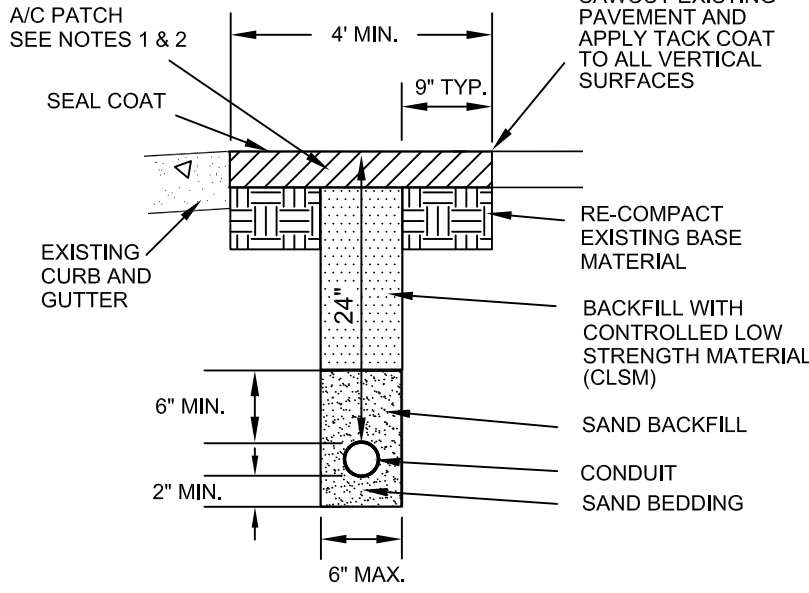

CONDUIT RETROFIT (EXIST. PAVEMENT)

NOTES (RETROFIT):

1. DEPTH TO MATCH EXISTING AC PAVEMENT, BUT NOT LESS THAN 4", PLACED IN MULTIPLE LIFTS OF EQUAL THICKNESS.
2. PATCH WIDTH SHALL BE SUFFICIENT TO ACCOMMODATE MECHANICAL PLACEMENT USING AGENCY APPROVED SPREADER BOX OR PAVING MACHINE, ROLLING AND COMPACTION PER UNIFORM STANDARD SPECIFICATION SECTION 401.03.11.
3. IF SAWCUT IS WITHIN 3 FEET OF EDGE OF EXISTING ASPHALT CONCRETE SURFACE OR OTHER PATCH, REMOVE EXISTING PAVEMENT TO THAT EDGE AND REPLACE ENTIRE SECTION.
4. IF 24" COVER IS NOT POSSIBLE, THEN RED CONCRETE ENCASEMENT MIN. 4" ABOVE CONDUIT REQUIRED.
5. CONTROLLED LOW STRENGTH MATERIAL (CLSM) MAY BE INSTALLED TO FINAL GRADE FOR TEMPORARY PATCHING.
6. PERMANENT PATCH MIX DESIGN SHALL BE AS REQUIRED BY ENGINEER.

Effective 01/01/09 - 06/30/09

SPECIFICATION REFERENCE	UNIFORM STANDARD DRAWINGS CLARK COUNTY AREA
	INSTALLATION OF CONDUIT
DATE	5-17-01
DWG. NO.	404.1419
SHEET	1 OF 1

CCTV CAMERA

COHU 3965 - 4101
(OR APPROVED EQUAL)

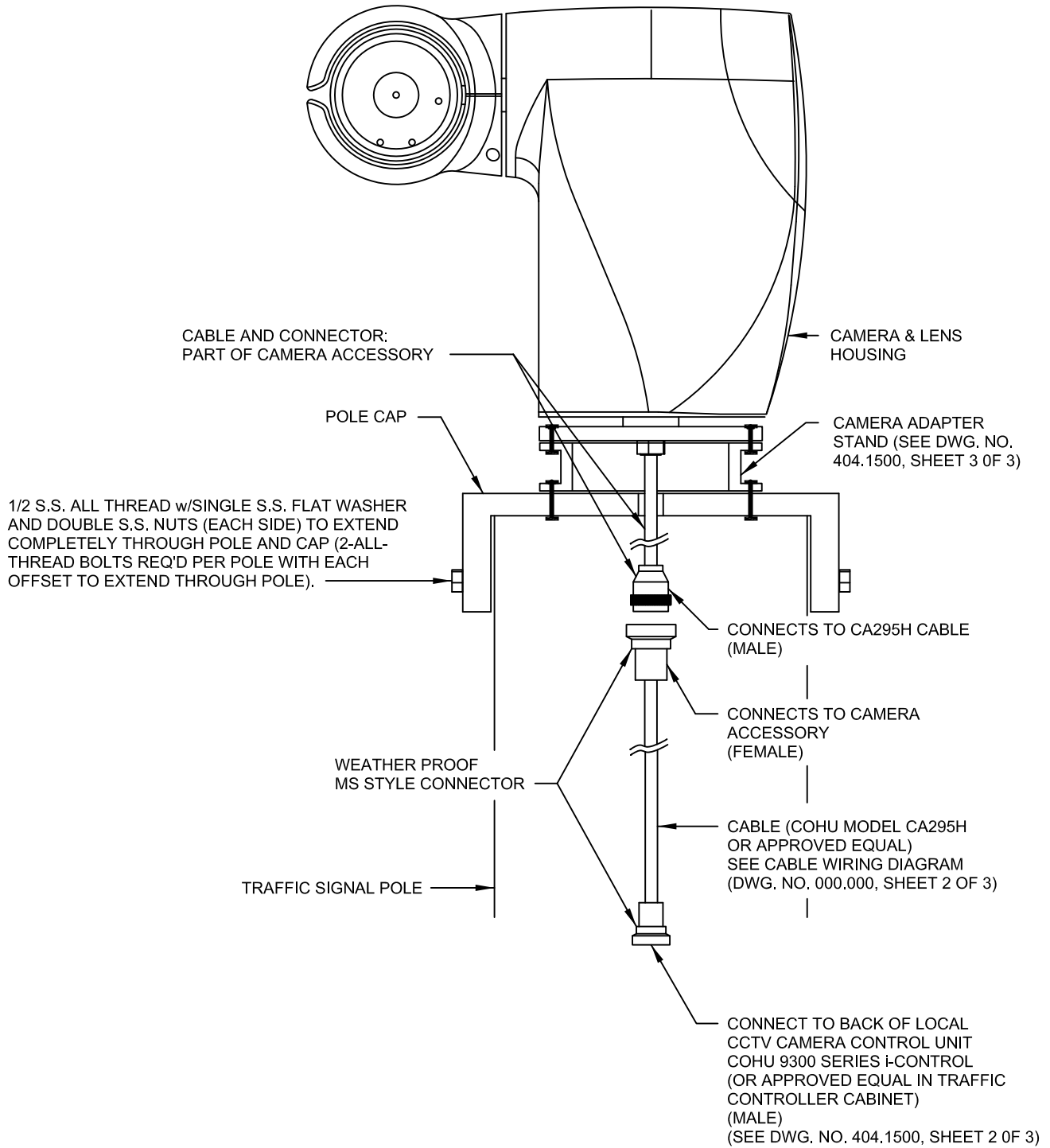

FOR CCTV AND CONTROL UNIT DETAILS
SEE 687 SPECIFICATIONS.

SPECIFICATION REFERENCE

UNIFORM STANDARD DRAWINGS
CLARK COUNTY AREA

CLOSED CIRCUIT TELEVISION
CAMERA

CONNECTOR
(MAIN)

AC38 7610176-001

CONNECTOR
(AMP)

VIDEO OUT
VIDEO SHIELD

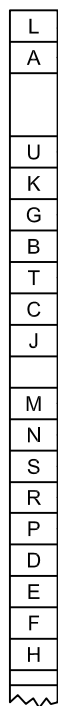

COAX

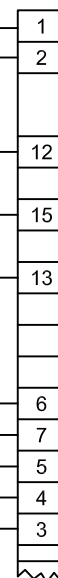

VIDEO
VIDEO GND

115 VAC HI

AC GND

115 VAC LO

RS422
RX+
RX-
TX+
TX-
DATA GND

BLK #22
RED #22
GRN #22
YEL #22
WHT #22
BLU #22

WHT #26
BLK #26
RED #26
GRN #26
BLU #26
ORG# 26
YEL #26
WHT/BLK #26
RED/GRN #26

TX+
TX-
RX+
RX-
DATA GND

**CCTV CAMERA
CA295H CABLE WIRING DIAGRAM**

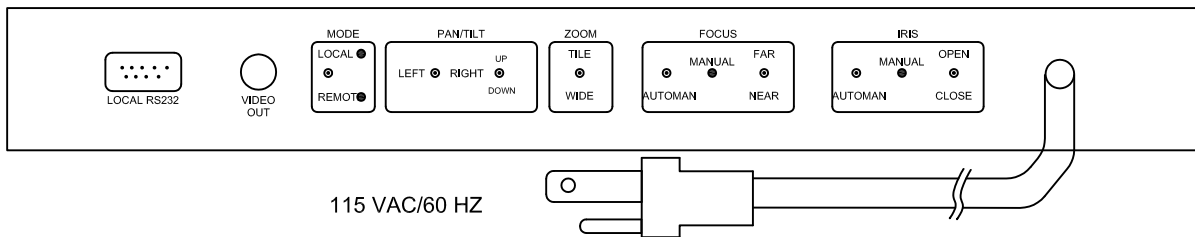
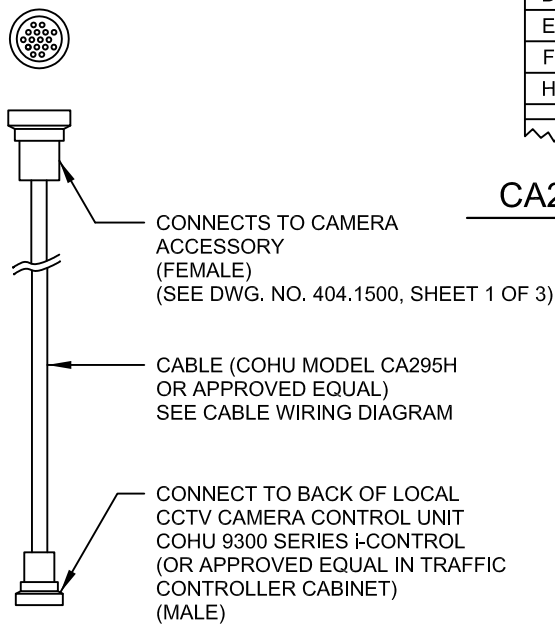

**LOCAL CCTV CAMERA CONTROL UNIT
COHU 9300 SERIES i-CONTROL
(OR APPROVED EQUAL)
(IN TRAFFIC CONTROLLER CABINET)**

SPECIFICATION REFERENCE

UNIFORM STANDARD DRAWINGS
CLARK COUNTY AREA

**CLOSED CIRCUIT TELEVISION CAMERA
CONTROL UNIT AND
CABLE WIRING DIAGRAM**

DATE 11-8-07

DWG. NO. 404.1500

SHEET 2 OF 3

CAMERA ADAPTER STAND

(REQUIRED FOR POLE CAP MOUNTING)

- 1. MAT'L (FLANGE): 1018 STEEL OR EQUIV.
- 2. MAT'L (TUBE): \varnothing 3.5 X 1/8 WALL 1018 STEEL OR EQUIV
- 3. FINISH: YELLOW CHROMATE CONVERSION COAT TYPE I PER MM-42 OR MIL-C-5541B CLASS 1A
- 4. PAINT ALL SURFACES LIGHT GRAY METAL FINE USING 3310042-478 PER MM-33 OR FEDERAL TEST METHOD STD NO.141. FINE TEXTURE OUTSIDE SURFACE ONLY AND OVERSPRAY PERMITTED.
- 5. REMOVE ALL BURRS AND SHARP EDGES 0.015 MAX

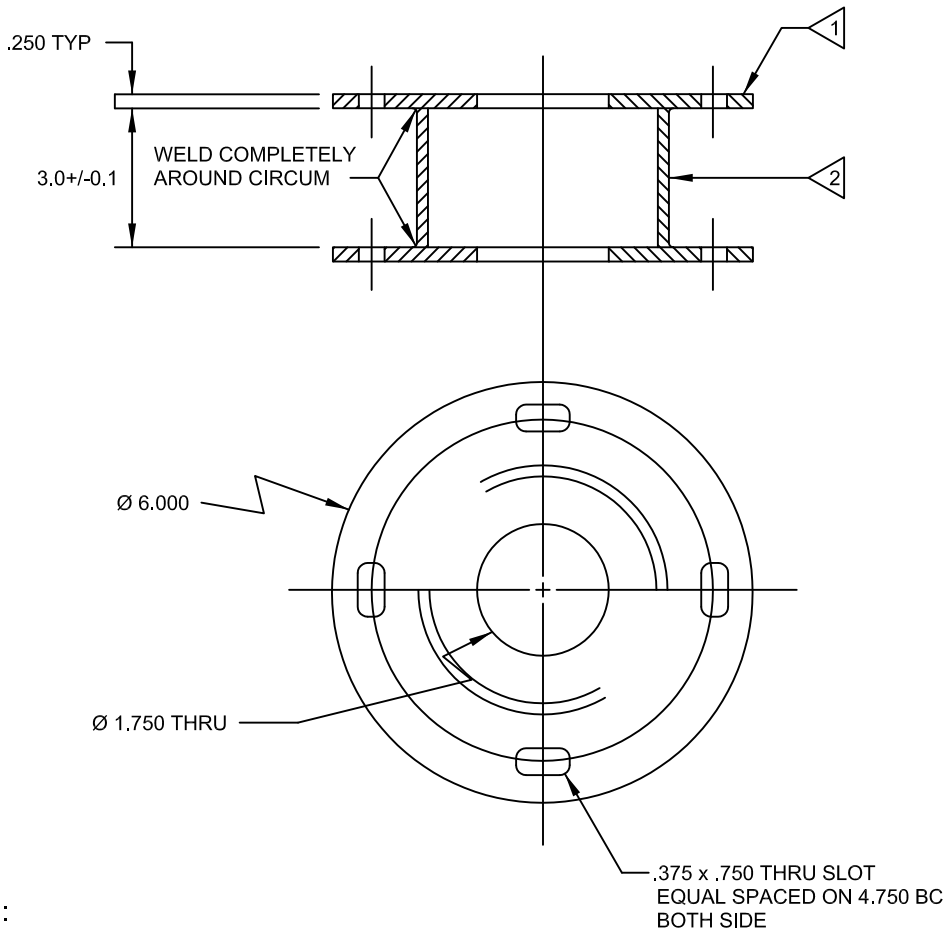

NOTE:

A 10' EXTENSION PROVIDED WHEN REQUIRED DESIGNED BY INSTALLER AND APPROVED BY RTC-FAST.

.375 x .750 THRU SLOT
EQUAL SPACED ON 4.750 BC
BOTH SIDE

SPECIFICATION REFERENCE

UNIFORM STANDARD DRAWINGS
CLARK COUNTY AREA

CAMERA ADAPTOR STAND