

**UNIFORM STANDARD DRAWINGS
CLARK COUNTY AREA**

VOLUME I - YEAR 2007 REVISIONS

Drawing Number	Title	Nature of Change	Effective Date
234.2A	"Typical Double Bus Stop Passenger Loading and Shelter Pads"	Addition of drawing to provide a detail for double bus stop loading and shelter pads.	01/01/07
300	"Streetlight Location General Notes"	Revised to allow 100 watt high pressure sodium luminaires on 60' Right-of-Way and less roadways and 250 watt high pressure sodium luminaires on 80' Right-of-Way and greater roadways in the City of Henderson.	07/01/07
303	"Streetlight Locations at Intersections 100' or Greater/60' Right-of-Way (Except Clark County & Henderson)"	Revised to allow 100 watt high pressure sodium luminaires on 60' Right-of-Way and less roadways and 250 watt high pressure sodium luminaires on 80' Right-of-Way and greater roadways in the City of Henderson.	07/01/07
303.1	"Streetlight Locations at Intersections 100' or Greater/60' Right-of-Way Clark County and Henderson only"	Revised to allow 100 watt high pressure sodium luminaires on 60' Right-of-Way and less roadways and 250 watt high pressure sodium luminaires on 80' Right-of-Way and greater roadways in the City of Henderson.	07/01/07
304	"Streetlight Locations at Intersections 100' or Greater/51' or Less Right-of-Way (Except Clark County & Henderson)"	Revised to allow 100 watt high pressure sodium luminaires on 60' Right-of-Way and less roadways and 250 watt high pressure sodium luminaires on 80' Right-of-Way and greater roadways in the City of Henderson.	07/01/07
304.1	"Streetlight Locations at Intersections 100' or Greater/51' or Less Right-of-Way Clark County and Henderson only"	Revised to allow 100 watt high pressure sodium luminaires on 60' Right-of-Way and less roadways and 250 watt high pressure sodium luminaires on 80' Right-of-Way and greater roadways in the City of Henderson.	07/01/07
306	"Streetlight Locations at Intersections 80'/60' Right-of-Way (Except Clark County & Henderson)"	Revised to allow 100 watt high pressure sodium luminaires on 60' Right-of-Way and less roadways and 250 watt high pressure sodium luminaires on 80' Right-of-Way and greater roadways in the City of Henderson.	07/01/07
306.1	"Streetlight Locations at Intersections 80'/60' Right-of-Way Clark County and Henderson only"	Revised to allow 100 watt high pressure sodium luminaires on 60' Right-of-Way and less roadways and 250 watt high pressure sodium luminaires on 80' Right-of-Way and greater roadways in the City of Henderson.	07/01/07

307	“Streetlight Locations at Intersections 80’/51’ or Less Right-of-Way (Except Clark County & Henderson)”	Revised to allow 100 watt high pressure sodium luminaires on 60’ Right-of-Way and less roadways and 250 watt high pressure sodium luminaires on 80’ Right-of-Way and greater roadways in the City of Henderson.	07/01/07
307.1	“Streetlight Locations at Intersections 80’/51’ or Less Right-of-Way Clark County and Henderson only”	Revision to allow 100 watt high pressure sodium luminaires on 60’ Right-of-Way and less roadways and 250 watt high pressure sodium luminaires on 80’ Right-of-Way and greater roadways in the City of Henderson.	
308	“Streetlight Locations at Intersections 60’/60’ Right-of-Way (Except Clark County & Henderson)”	Revised to allow 100 watt high pressure sodium luminaires on 60’ Right-of-Way and less roadways and 250 watt high pressure sodium luminaires on 80’ Right-of-Way and greater roadways in the City of Henderson.	07/01/07
308.1	“Streetlight Locations at Intersections 60’/60’ Right-of-Way Clark County and Henderson only”	Revised to allow 100 watt high pressure sodium luminaires on 60’ Right-of-Way and less roadways and 250 watt high pressure sodium luminaires on 80’ Right-of-Way and greater roadways in the City of Henderson.	07/01/07
309	“Streetlight Locations at Intersections 60’/51’ or Less Right-of-Way (Except Clark County & Henderson)”	Revised to allow 100 watt high pressure sodium luminaires on 60’ Right-of-Way and less roadways and 250 watt high pressure sodium luminaires on 80’ Right-of-Way and greater roadways in the City of Henderson.	07/01/07
309.1	“Streetlight Locations at Intersections 60’/51’ or Less Right-of-Way Clark County and Henderson only”	Revised to allow 100 watt high pressure sodium luminaires on 60’ Right-of-Way and less roadways and 250 watt high pressure sodium luminaires on 80’ Right-of-Way and greater roadways in the City of Henderson.	07/01/07
310	“Streetlight Locations at Intersections 51’ or Less / 51’ or Less Right-of-Way”	Revised to allow 100 watt high pressure sodium luminaires on 60’ Right-of-Way and less roadways and 250 watt high pressure sodium luminaires on 80’ Right-of-Way and greater roadways in the City of Henderson.	07/01/07
311A	“Streetlight Standards Maximum Spacing (60 FT. or Less Right-of-Way) (Except Clark County and Henderson)”	Revised to allow 100 watt high pressure sodium luminaires on 60’ Right-of-Way and less roadways and 250 watt high pressure sodium luminaires on 80’ Right-of-Way and greater roadways in the City of Henderson.	07/01/07
311.1A	“Streetlight Standards Maximum Spacing (60 FT. or Less Right-of-Way) Clark County and Henderson only”	Revised to allow 100 watt high pressure sodium luminaires on 60’ Right-of-Way and less roadways and 250 watt high pressure sodium luminaires on 80’ Right-of-Way and greater roadways in the City of Henderson.	07/01/07

328	"Utility Pull Box Locations Sidewalk and Between Driveways"	Revised to add a note to refer to Uniform and Design Construction Standards (UDACS) Plate 1A 1D for water service utility boxes. "Utility Pull Box Locations Sidewalk and Between Driveways."	07/01/07
411A	"Modified Type "A" Drop Inlet"	Addition of drawing to improve structural strength of drop inlets. "Modified Type "A" Drop Inlet" - inlets.	01/01/07
412A	"Type C-D Modified Drop Inlet"	Addition of drawing to improve structural strength of drop inlets. "Type C-D Modified Drop Inlet."	01/01/07
502	"Method B for Rigid and Flexible Pipe Trench Backfill – Unpaved Areas and Areas Outside Existing or Future Proposed Street Right-of-Way"	Revision to adopt consistent quality control, testing of materials and minimum quality standards. "Method B for Rigid and Flexible Pipe Trench Backfill – Unpaved Areas and Areas Outside Existing or Future Proposed Street Right-of-Way."	01/01/07
502A	"Method A for Flexible Pipe Trench Backfill – Unpaved Areas and Areas Outside Existing or Future Proposed Street Right-of-Way"	Addition of drawing to adopt consistent quality control, testing of materials and minimum quality standards. "Method A for Flexible Pipe Trench Backfill – Unpaved Areas and Areas Outside Existing or Future Proposed Street Right-of-Way."	01/01/07
502B	"Method A for Rigid Pipe Trench Backfill -Unpaved Areas and Areas Outside Existing or Future Proposed Street Right-of-Way"	Addition of drawing to adopt consistent quality control, testing of materials and minimum quality standards. "Method A for Rigid Pipe Trench Backfill - Unpaved Areas and Areas Outside Existing or Future Proposed Street Right-of-Way."	01/01/07
503	"Method B for Rigid and Flexible Pipe Trench Backfill – Paved Areas and Areas Outside Existing or Future Proposed Street Right-of-Way"	Revision to adopt consistent quality control, testing of materials and minimum quality standards. "Method B for Rigid and Flexible Pipe Trench Backfill – Paved Areas and Areas Outside Existing or Future Proposed Street Right-of-Way."	01/01/07
503A	"Method A for Flexible Pipe Trench Backfill – Paved Areas and Areas Outside Existing or Future Proposed Street Right-of-Way"	Addition of drawing to adopt consistent quality control, testing of materials and minimum quality standards. "Method A for Flexible Pipe Trench Backfill – Paved Areas and Areas Outside Existing or Future Proposed Street Right-of-Way."	01/01/07
503B	"Method A for Rigid Pipe Trench Backfill – Paved Areas and Areas Outside Existing or Future Proposed Street Right-of-Way"	Addition of drawing to adopt consistent quality control, testing of materials and minimum quality standards. "Method A for Rigid Pipe Trench Backfill – Paved Areas and Areas Outside Existing or Future Proposed Street Right-of-Way."	01/01/07
505	"Pipe Trench Bedding Methods"	Revision to adopt consistent quality control, testing of materials and minimum quality standard. "Pipe Trench Bedding Methods."	01/01/07

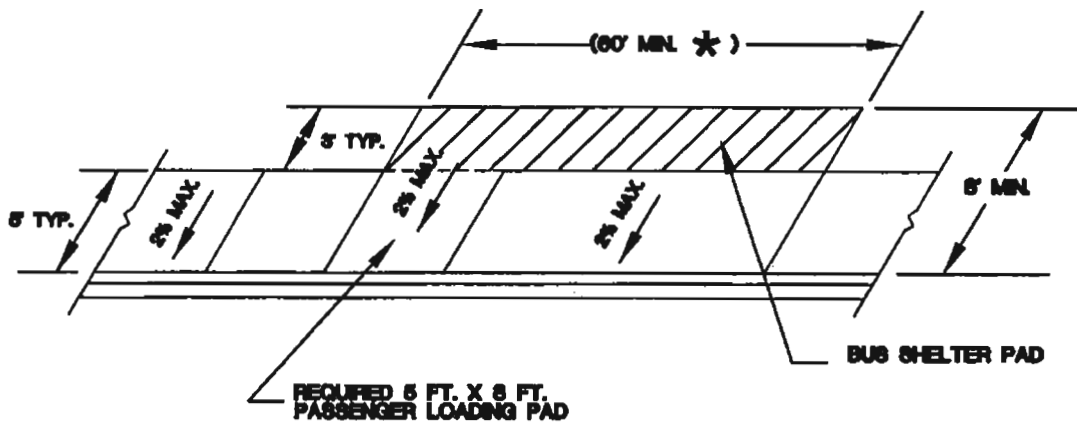

 ADDITIONAL AREA REQUIRED BEHIND TYPICAL 5 FT. SIDEWALK FOR PASSENGER LOADING PAD

★ ADDITIONAL 30 FEET MAY BE REQUIRED BY RTC.

NOTES:

1. SIDEWALK RAMP MAY BE REQUIRED TO BE CONSTRUCTED IN THOSE LOCATIONS WHERE THE BUS STOP WOULD OTHERWISE BE INACCESSIBLE AS DEFINED BY THE AMERICANS WITH DISABILITIES ACT. SEE DRAWING NO. 236, SHEET 4 OF 5 FOR SIDEWALK RAMP DETAILS.
2. ADDITIONAL RIGHT-OF-WAY OR EASEMENT IS REQUIRED FOR LOADING PAD AND VARIABLE HEIGHT CURB AT BACK OF SIDEWALK RAMP.
3. AGGREGATE BASE AND CONCRETE FOR LOADING PAD SHALL BE THE SAME AS REQUIRED FOR SIDEWALK. SEE DRAWING NO. 234.
4. LOADING PAD CONNECTION TO DETACHED SIDEWALK CONDITION SHALL BE DETERMINED BY THE ENTITIES.

SPECIFICATION REFERENCE		UNIFORM STANDARD DRAWINGS CLARK COUNTY AREA	
302	AGGREGATE BASE	TYPICAL DOUBLE BUS STOP PASSENGER LOADING AND SHELTER PADS	
501	CONCRETE		
502	CONCRETE STRUCTURES		
		DATE 9-14-08	DWG. NO. 234.2A

1. INSTALL STREETLIGHT STANDARDS AT INTERSECTIONS INCLUDING "L" AND "T" TYPES, PER STANDARD DRAWINGS 301 THROUGH 310 IN ACCORDANCE WITH THE APPROPRIATE RIGHT-OF-WAY.

2. STREET CLASSIFICATION AND STREETLIGHT STANDARD APPLICATION SHALL BE AS LISTED IN TABLE 1 BELOW. ACTUAL LUMINAIRE WATTAGE AND/OR STREETLIGHT STANDARD SPACING MAY BE VARIED BY THE ENGINEER, WHEN SUPPORTED BY AN APPROVED LIGHTING STUDY IN ACCORDANCE WITH THE IES RECOMMENDED PRACTICE FOR ROADWAY LIGHTING IN ORDER TO MEET CURRENT AND FUTURE TRAFFIC CONTROL NEEDS AND APPROVED BY THE RESPECTIVE AGENCY. AVERAGE LEVELS ARE MAINTAINED LEVELS AT A 0.8 MAINTENANCE FACTOR (0.82 FOR CLARK COUNTY) IN FOOTCANDLES MEASURED HORIZONTALLY AT THE SURFACE.

TABLE 1

<u>CLASSIFICATION</u>	<u>R/W</u>	<u>DWG</u>	<u>LUMINAIRE</u>	<u>AVERAGE IES LIGHTING LEVEL</u>	<u>IES UNIFORMITY AVG./MIN</u>
MAJOR ARTERIAL	100' OR MORE	---	250W HP8	158 FC	3:1
INTERMEDIATE COLLECTOR	60'	---	150W HP8 250W HP8 (CLARK COUNTY & COH ONLY)	0.84 FC	4:1
LOCAL	60'	---	150W HP8 100W HP8 (CLARK COUNTY & COH ONLY)	0.88 FC	6:1
RESIDENTIAL	60' OR LESS	---	100W HP8	0.88 FC	6:1

3. NEW STREETLIGHT STANDARDS INSTALLED ADJACENT TO OR OPPOSITE FROM EXISTING STREETLIGHTS SHALL MATCH THE EXISTING LOCATION, SPACING, POLE AND LUMINAIRE TYPES UNLESS OTHERWISE DIRECTED BY THE ENGINEER.

4. STREETLIGHT STANDARDS INSTALLED ON 60' OR LESS RIGHT-OF-WAYS MAY BE INSTALLED ON EITHER SIDE OF ROADWAY AS DIRECTED BY THE ENGINEER.

5. TRAFFIC SIGNAL FOUNDATIONS AND ADAPTOR PLATES MAY BE REQUIRED AT INTERSECTIONS AS DIRECTED BY THE ENGINEER.

6. AT LEAST ONE STREETLIGHT SHALL BE REQUIRED IN THE BULB SECTION OF A CUL-DE-SAC OR HAMMERHEAD. LOCATION SHALL BE AS REQUIRED BY THE ENGINEER.

• PROFESSIONAL ELECTRICAL ENGINEER STAMP ON FILE

SPECIFICATION REFERENCE		UNIFORM STANDARD DRAWINGS CLARK COUNTY AREA	
623	TRAFFIC SIGNALS & STREETLIGHTING		
		STREETLIGHT LOCATION GENERAL NOTES	
		DATE 2-08-07	DWG. NO. 300

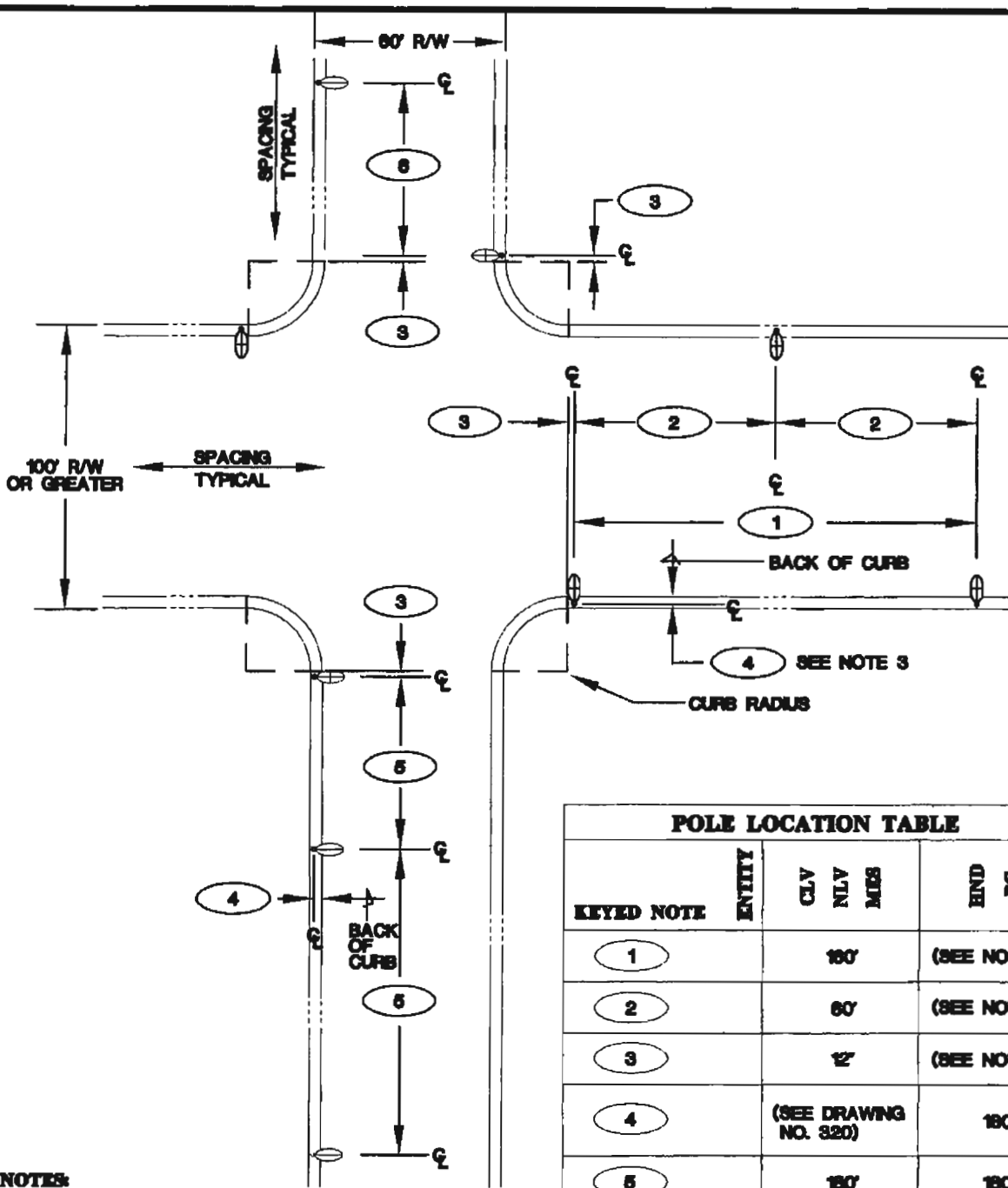

- NOTES:**
1. SEE GENERAL NOTES STANDARD DRAWING NO. 300.
 2. AN APPROVED LIGHTING STUDY PER NOTE 2, STANDARD DRAWING NO. 300 IS REQUIRED FOR RIGHT-OF-WAY GREATER THAN 100 FEET.
 3. CITY OF HENDERSON AND BOULDER CITY REQUIRE STREETLIGHTING IN THE MEDIAN FOR RIGHTS-OF-WAY 100 FEET OR GREATER. SEE STANDARD DRAWING NO. 312. IN THE ABSENCE OF A MEDIAN, STREETLIGHT LOCATION SHALL BE THE SAME AS THE OTHER ENTITIES.

• PROFESSIONAL ELECTRICAL ENGINEER STAMP ON FILE

POLE LOCATION TABLE						
KEYED NOTE	ENTITY	CLV	NLV	MIS	HND	BC
1		10'			(SEE NOTE 3)	
2		6'			(SEE NOTE 3)	
3		1'			(SEE NOTE 3)	
4		(SEE DRAWING NO. 320)			18'	
5		18'			18'	
6		8'			8'	

SPECIFICATION REFERENCE		UNIFORM STANDARD DRAWINGS CLARK COUNTY AREA	
623	TRAFFIC SIGNALS & STREETLIGHTING	STREETLIGHT LOCATIONS AT INTERSECTIONS 100' OR GREATER/60' RIGHT-OF-WAY (EXCEPT CLARK COUNTY & HENDERSON)	
		DATE 2-08-07	DWG. NO. 303

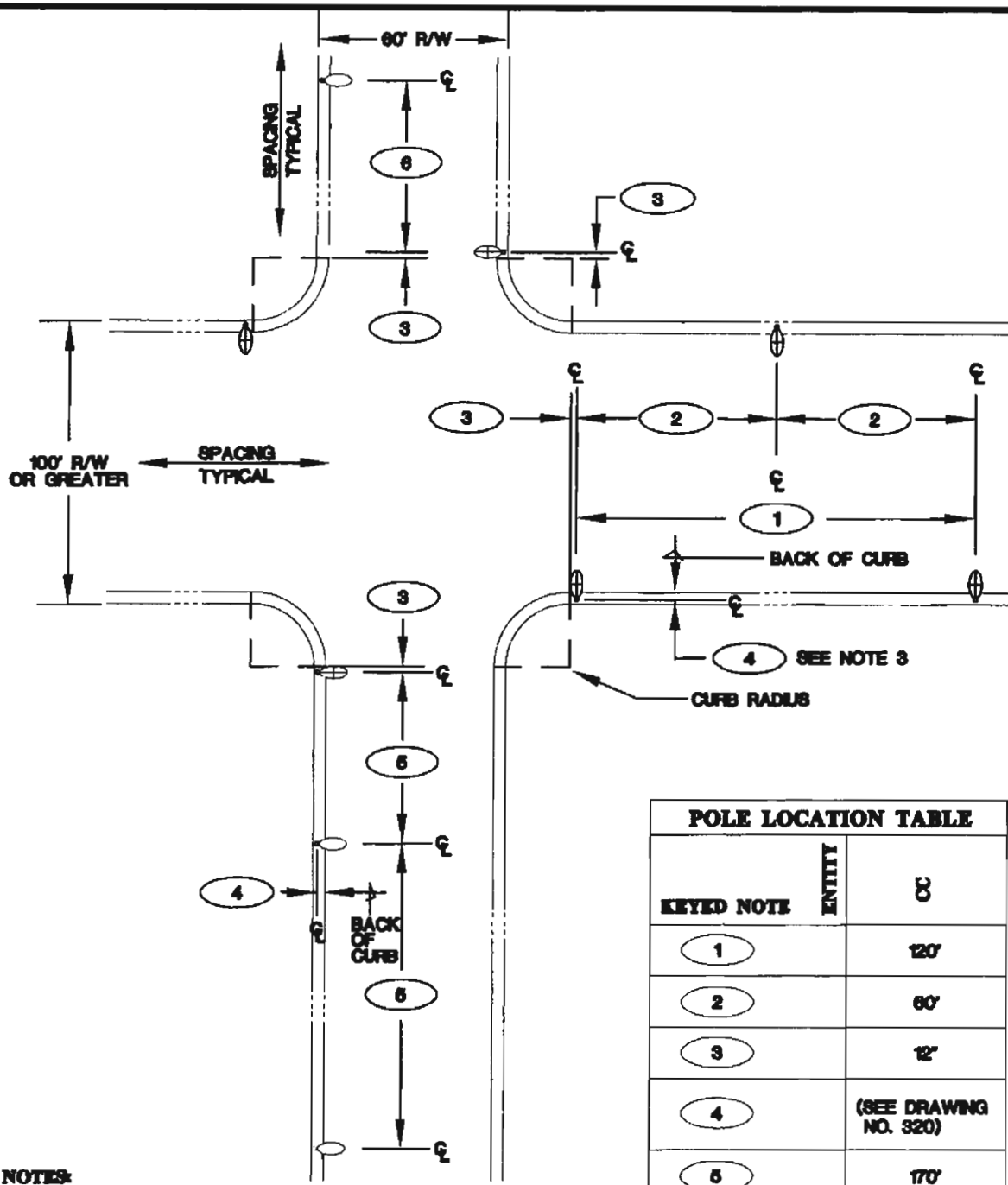

NOTES:

- 1. SEE GENERAL NOTES STANDARD DRAWING NO. 300.
- 2. AN APPROVED LIGHTING STUDY PER NOTE 2, STANDARD DRAWING NO. 300 IS REQUIRED FOR RIGHT-OF-WAY GREATER THAN 100 FEET.
- 3. IF INTERSECTION IS SIGNALIZED, 400 WATT LUMINAIRES SHALL BE INSTALLED ON ALL CORNERS AND DUAL ARM CONFIGURATION SHALL BE USED FOR 100 FT. RIGHT-OF-WAY SIMILAR TO STANDARD DRAWING NO. 302.1 IN CLARK COUNTY. USE SIGLE ARM CONFIGURATION PER DRAWING 302 IN HENDERSON.

• PROFESSIONAL ELECTRICAL ENGINEER STAMP ON FILE

SPECIFICATION REFERENCE		UNIFORM STANDARD DRAWINGS CLARK COUNTY AREA	
623	TRAFFIC SIGNALS & STREETLIGHTING	CLARK COUNTY & HENDERSON ONLY	
		STREETLIGHT LOCATIONS AT INTERSECTIONS 100' OR GREATER/60' RIGHT-OF-WAY	
		DATE 2-08-07	DWG. NO. 303.1

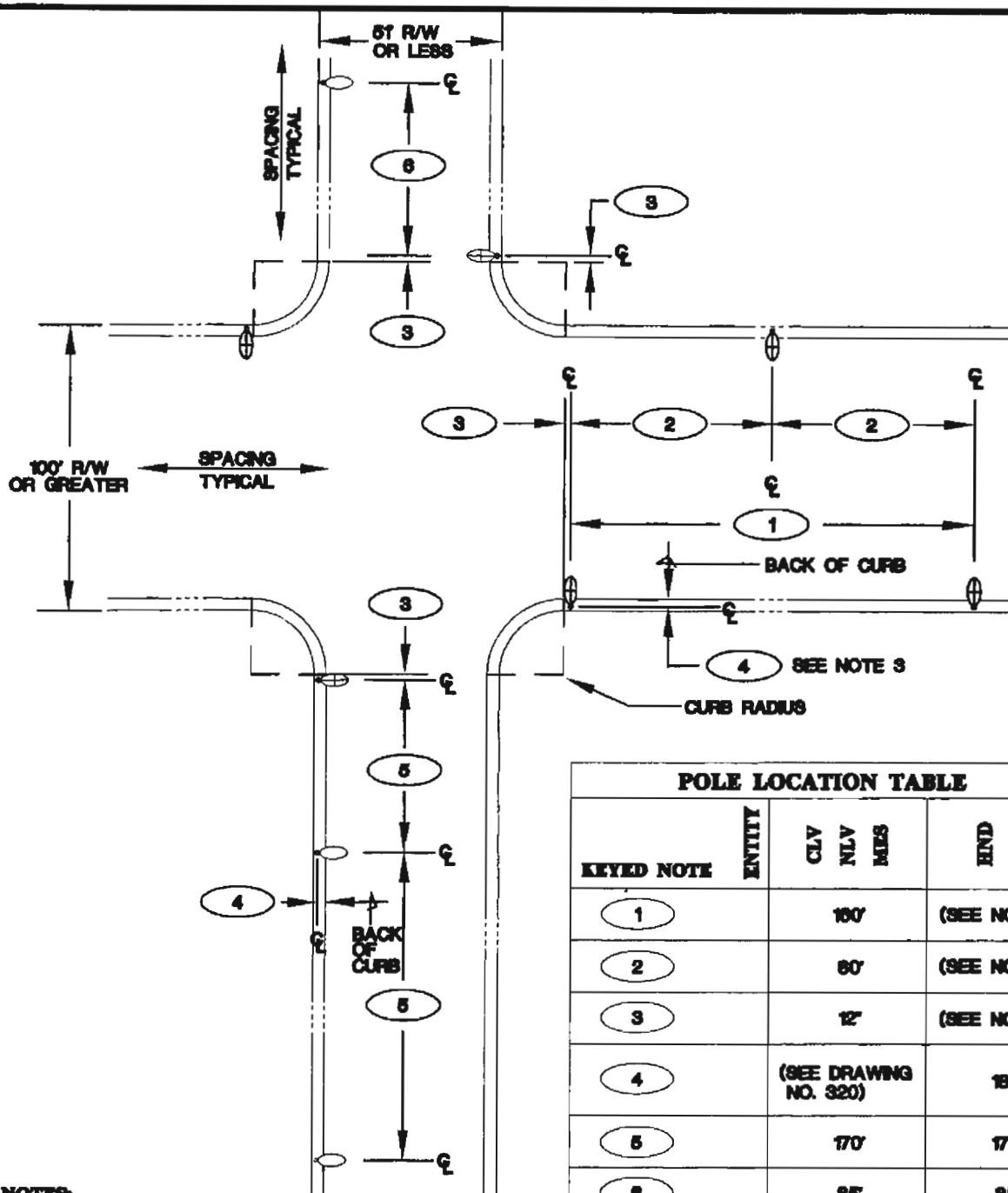

KEYED NOTE	ENTITY	HND BC		
		CLY	NLY	MBS
1		100'		(SEE NOTE 3)
2		80'		(SEE NOTE 3)
3		12'		(SEE NOTE 3)
4		(SEE DRAWING NO. 320)		180'
5		170'		170'
6		85'		85'

NOTES:

1. SEE GENERAL NOTES STANDARD DRAWING NO. 300.
2. AN APPROVED LIGHTING STUDY PER NOTE 2, STANDARD DRAWING NO. 300 IS REQUIRED FOR RIGHT-OF-WAY GREATER THAN 100 FEET. ADEQUATE INTERSECTION LIGHTING SHALL ALSO BE ADDRESSED IN THE LIGHTING STUDY.
3. CITY OF HENDERSON AND BOULDER CITY REQUIRE STREETLIGHTING IN THE MEDIAN FOR RIGHTS-OF-WAY 100 FEET OR GREATER. SEE STANDARD DRAWING NO. 312. IN THE ABSENCE OF A MEDIAN, STREETLIGHT LOCATION SHALL BE THE SAME AS THE OTHER ENTITIES.

• PROFESSIONAL ELECTRICAL ENGINEER STAMP ON FILE.

SPECIFICATION REFERENCE		UNIFORM STANDARD DRAWINGS CLARK COUNTY AREA	
623	TRAFFIC SIGNALS & STREETLIGHTING		
		STREETLIGHT LOCATIONS AT INTERSECTIONS 100' OR GREATER/5T OR LESS RIGHT-OF-WAY (EXCEPT CLARK COUNTY & HENDERSON)	
		DATE 2-08-07	DWG. NO. 304

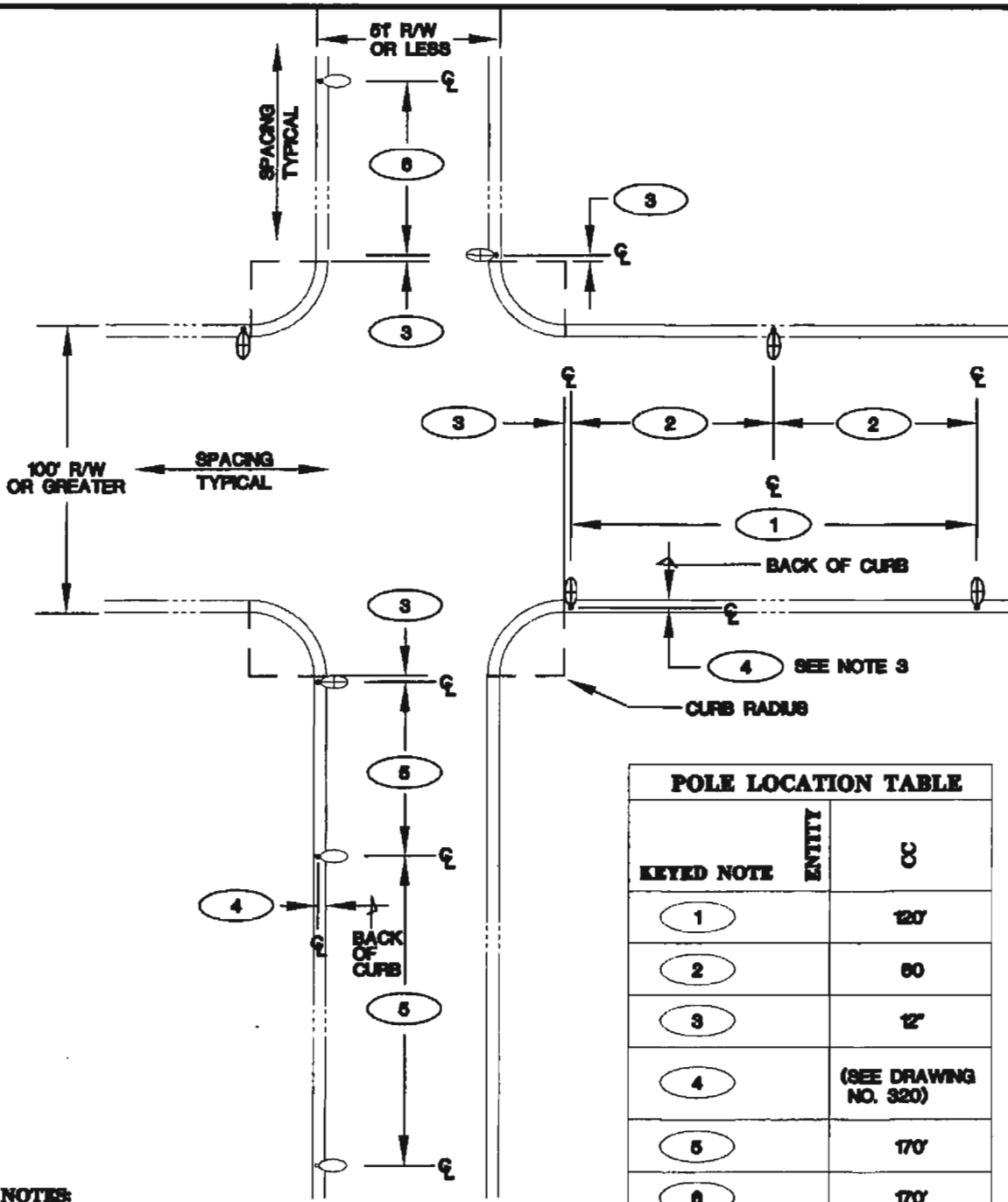

NOTES:

1. SEE GENERAL NOTES STANDARD DRAWING NO. 300.
2. AN APPROVED LIGHTING STUDY PER NOTE 2, STANDARD DRAWING NO. 300 IS REQUIRED FOR RIGHT-OF-WAY GREATER THAN 100 FEET. ADEQUATE INTERSECTION LIGHTING SHALL ALSO BE ADDRESSED IN THE LIGHTING STUDY.
3. IF INTERSECTION IS SIGNALIZED, 400 WATT LUMINAIRES SHALL BE INSTALLED ON ALL CORNERS AND DUAL ARM CONFIGURATION SHALL BE USED FOR 100 FT. RIGHT-OF-WAY SIMILAR TO STANDARD DRAWING NO. 302.1 IN CLARK COUNTY. USE SINGLE ARM CONFIGURATION PER DRAWING 302 IN HENDERSON.

• PROFESSIONAL ELECTRICAL ENGINEER STAMP ON FILE.

SPECIFICATION REFERENCE		UNIFORM STANDARD DRAWINGS CLARK COUNTY AREA	
623	TRAFFIC SIGNALS & STREETLIGHTING	CLARK COUNTY & HENDERSON ONLY	
		STREETLIGHT LOCATIONS AT INTERSECTIONS 100' OR GREATER/5T OR LESS RIGHT-OF-WAY	
		DATE 2-08-07	DWG. NO. 304.1

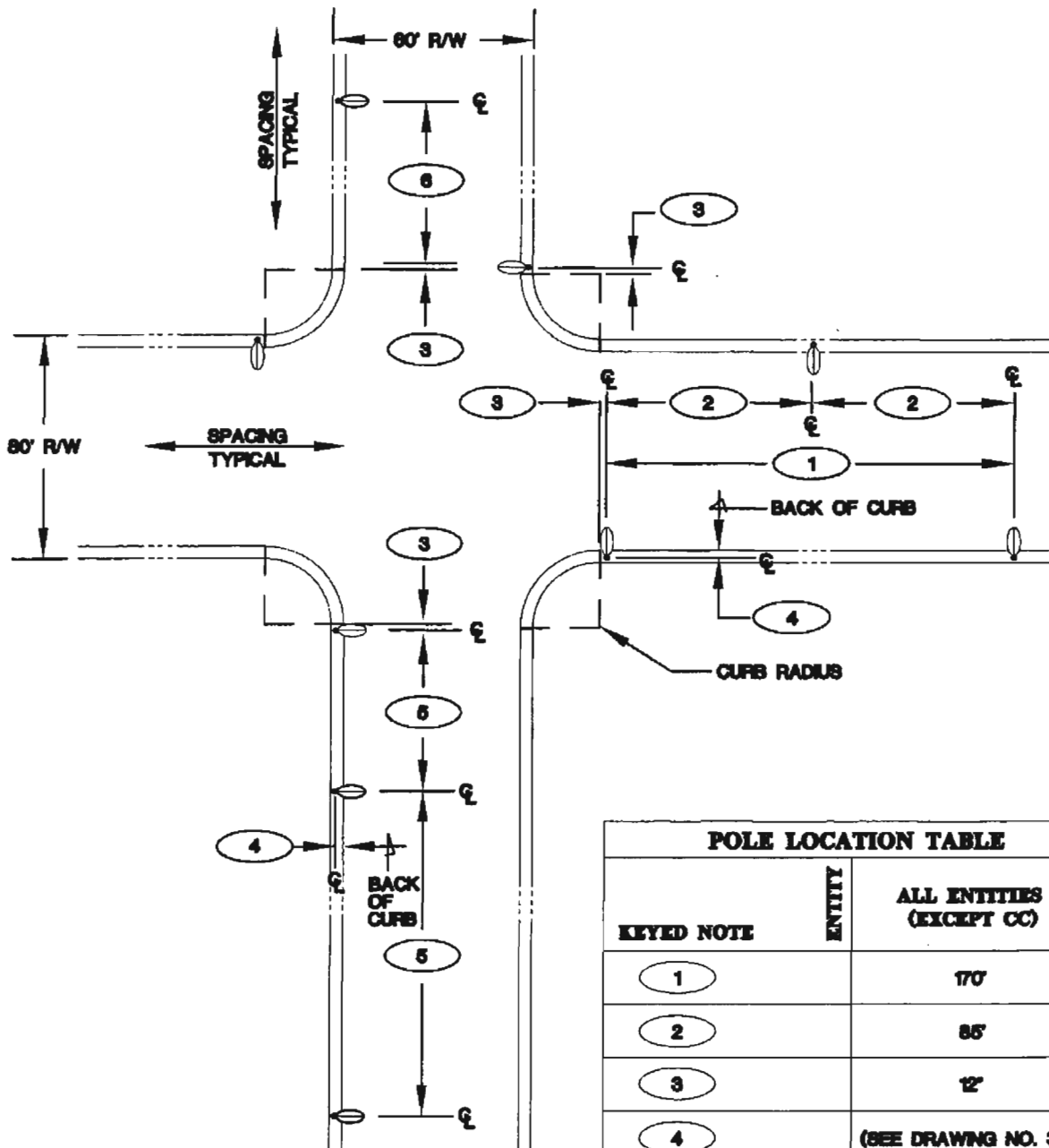

POLE LOCATION TABLE		
KEYED NOTE	ENTITY	ALL ENTITIES (EXCEPT CC)
1		170'
2		85'
3		12'
4		(SEE DRAWING NO. 320)
5		180'
6		90'

NOTE:
SEE GENERAL NOTES STANDARD DRAWING NO. 300.

• PROFESSIONAL ELECTRICAL ENGINEER STAMP ON FILE

SPECIFICATION REFERENCE		UNIFORM STANDARD DRAWINGS CLARK COUNTY AREA	
623	TRAFFIC SIGNALS & STREETLIGHTING	STREETLIGHT LOCATIONS AT INTERSECTIONS 80'/60' RIGHT-OF-WAY (EXCEPT CLARK COUNTY & HENDERSON)	
		DATE 2-08-07	DWG. NO. 306

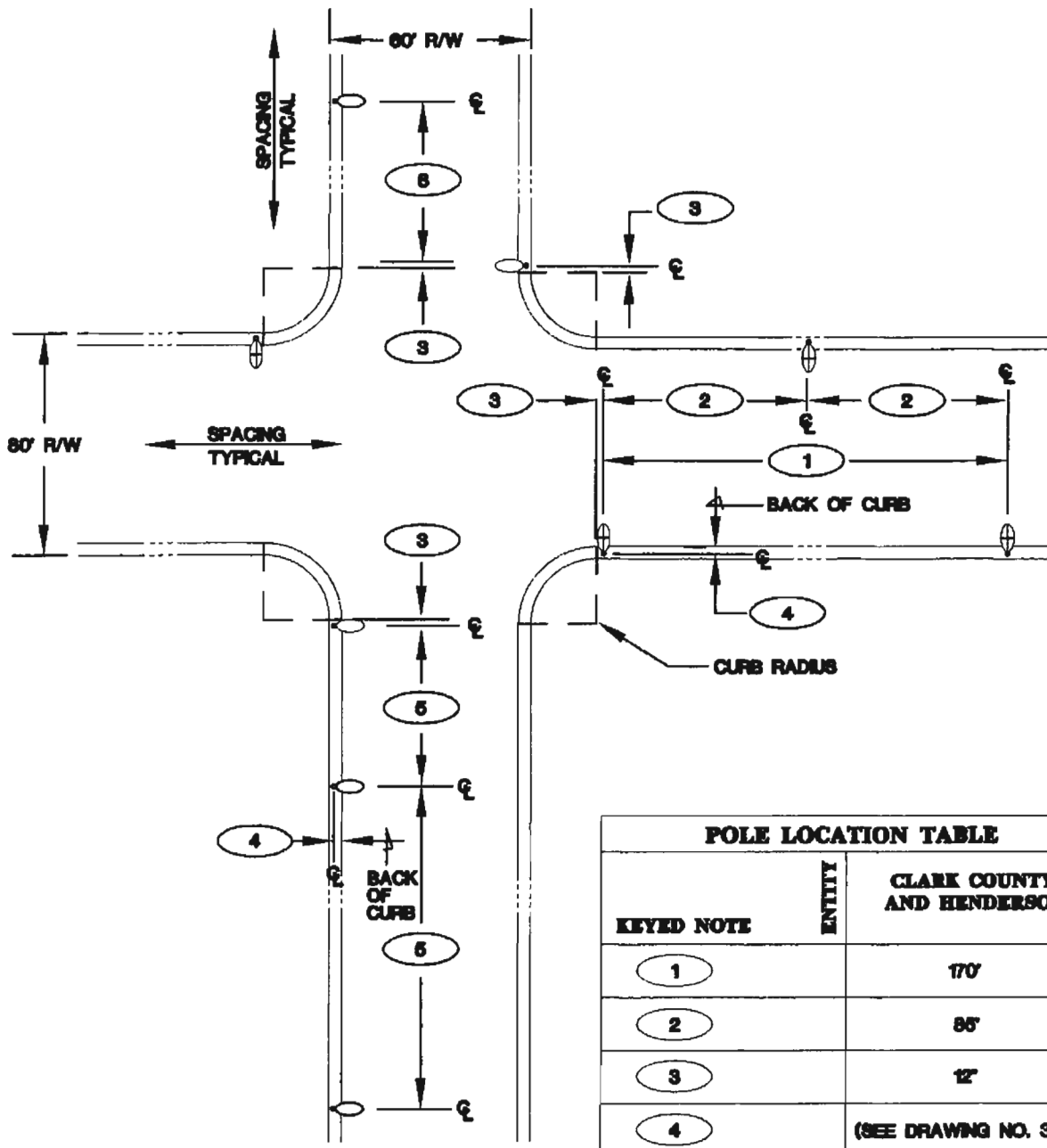

POLE LOCATION TABLE		
KEYED NOTE	ENTITY	CLARK COUNTY AND HENDERSON
1		170'
2		85'
3		12'
4		(SEE DRAWING NO. 320)
5		170'
6		85'

NOTE:

- 1. SEE GENERAL NOTES STANDARD DRAWING NO. 300.
- 2. IF THE INTERSECTION IS SIGNALIZED, 400 WATT LUMINAIRES SHALL BE INSTALLED ON ALL CORNERS.

• PROFESSIONAL ELECTRICAL ENGINEER STAMP ON FILE.

SPECIFICATION REFERENCE		UNIFORM STANDARD DRAWINGS CLARK COUNTY AREA	
623	TRAFFIC SIGNALS & STREETLIGHTING	CLARK COUNTY & HENDERSON ONLY	
		STREETLIGHT LOCATIONS AT INTERSECTIONS 80'/60' RIGHT-OF-WAY	
		DATE 2-08-07	DWG. NO. 308.1

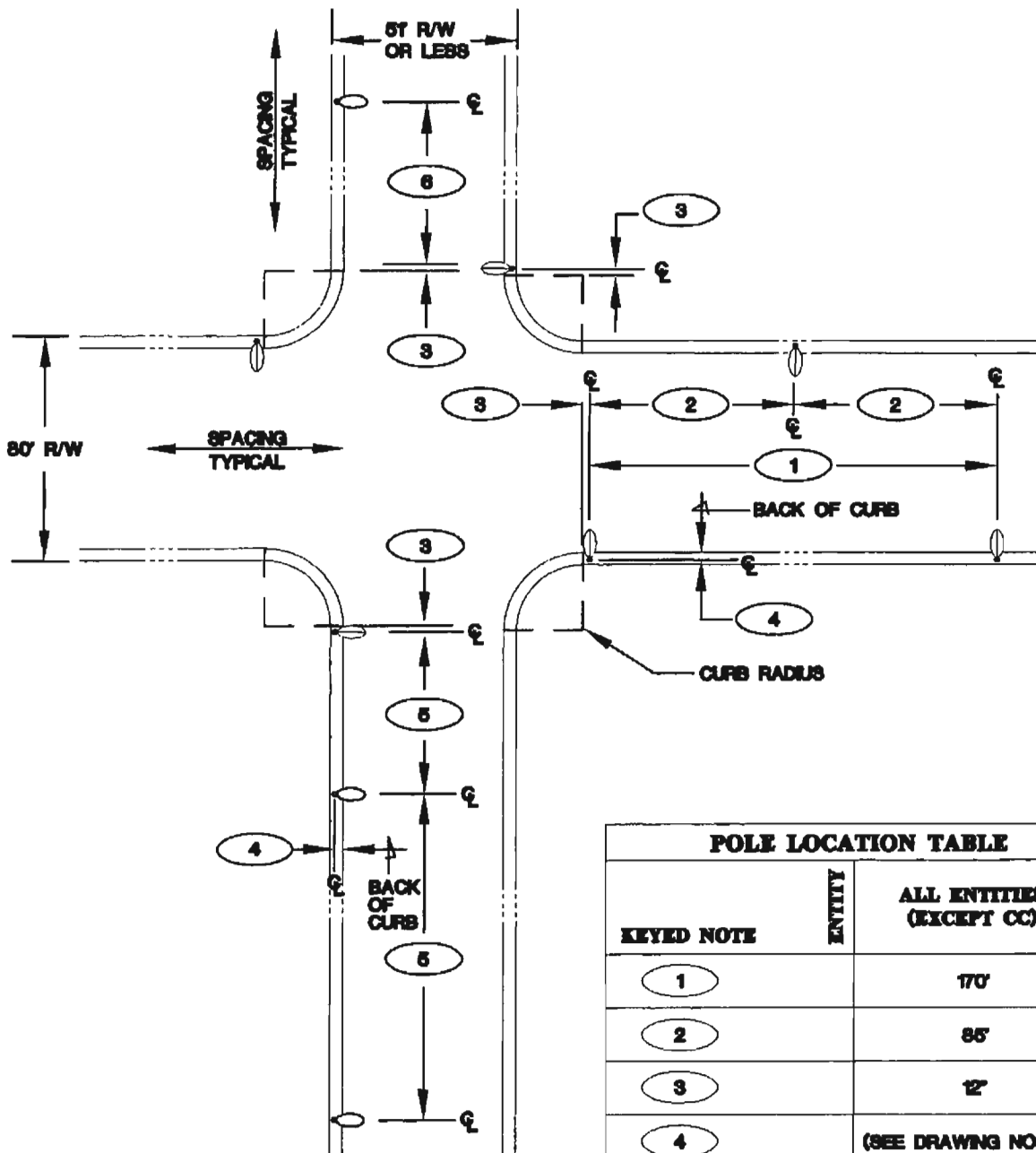

POLE LOCATION TABLE		
KEYED NOTE	ENTITY	ALL ENTITIES (EXCEPT CC)
1		170'
2		85'
3		12'
4		(SEE DRAWING NO. 320)
5		170'
6		85'

NOTE:
SEE GENERAL NOTES STANDARD DRAWING NO. 300.

• PROFESSIONAL ELECTRICAL ENGINEER STAMP ON FILE.

SPECIFICATION REFERENCE		UNIFORM STANDARD DRAWINGS CLARK COUNTY AREA	
623	TRAFFIC SIGNALS & STREETLIGHTING	STREETLIGHT LOCATIONS AT INTERSECTIONS 80'/5T OR LESS RIGHT-OF-WAY (EXCEPT CLARK COUNTY & HENDERSON)	
		DATE 2-08-07	DWG. NO. 307

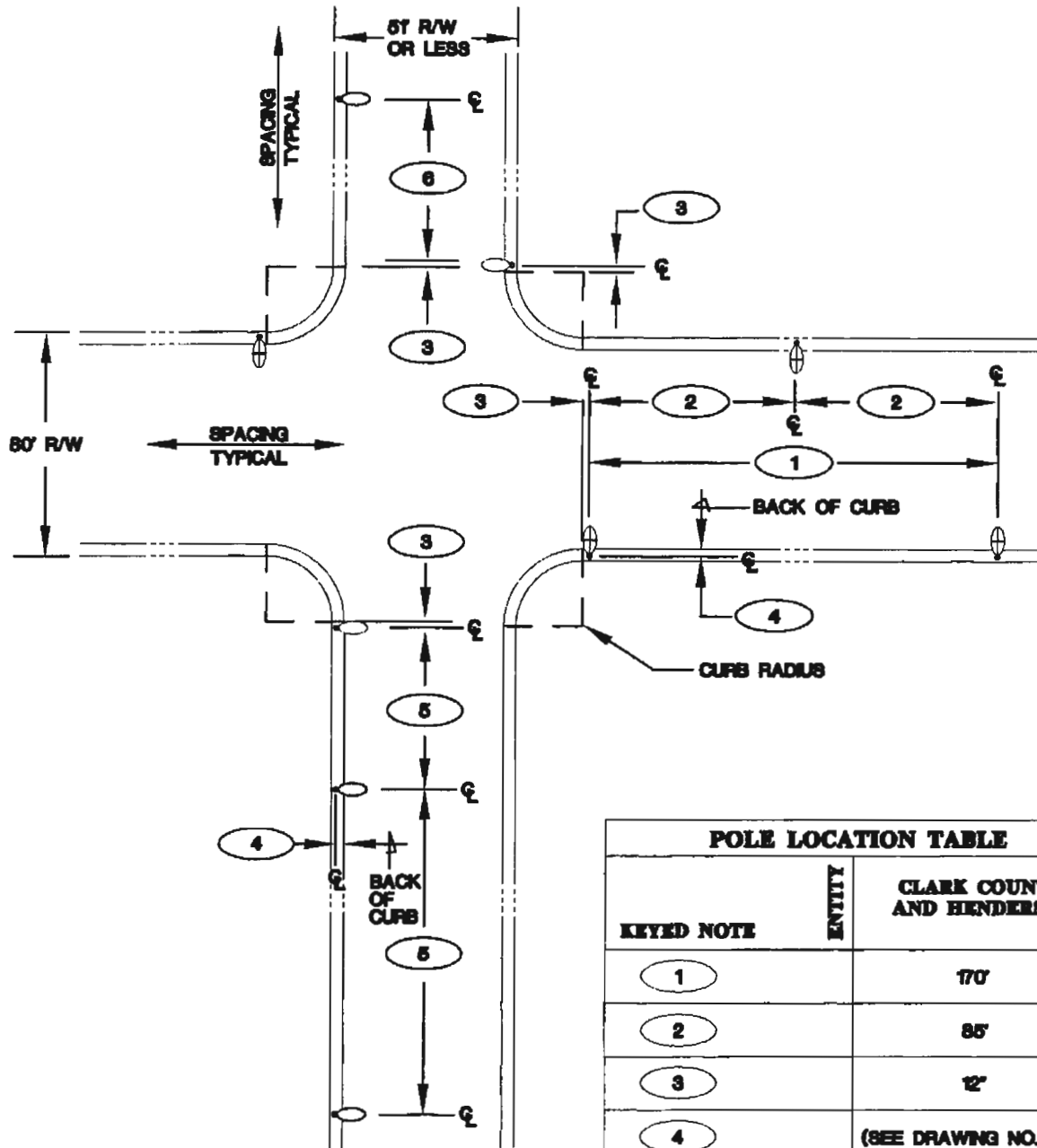

POLE LOCATION TABLE	
KEYED NOTE	ENTITY
1	CLARK COUNTY AND HENDERSON 170'
2	85'
3	12'
4	(SEE DRAWING NO. 320)
5	170'
6	85'

NOTE:

1. SEE GENERAL NOTES STANDARD DRAWING NO. 300.
2. IF INTERSECTION IS SIGNALIZED, 400 WATT LUMINAIRES SHALL BE INSTALLED ON ALL CORNERS.

• PROFESSIONAL ELECTRICAL ENGINEER STAMP ON FILE

SPECIFICATION REFERENCE		UNIFORM STANDARD DRAWINGS CLARK COUNTY AREA	
623	TRAFFIC SIGNALS & STREETLIGHTING	CLARK COUNTY & HENDERSON ONLY	
		STREETLIGHT LOCATIONS AT INTERSECTIONS 80'/51' OR LESS RIGHT-OF-WAY	
		DATE 2-08-07	DWG. NO. 307.1

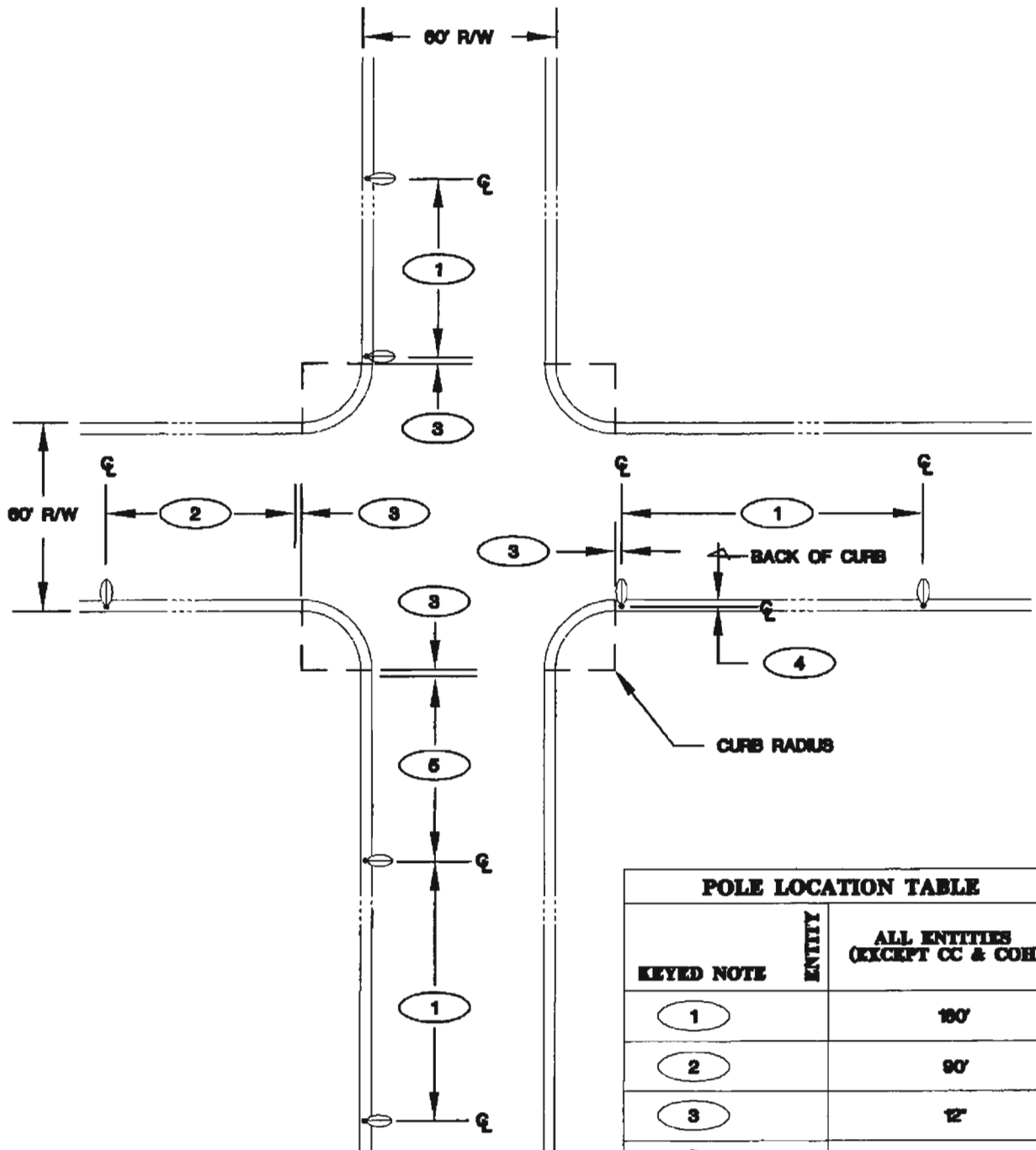

NOTE:

SEE GENERAL NOTES STANDARD DRAWING NO. 300.

• PROFESSIONAL ELECTRICAL ENGINEER STAMP ON FILE.

SPECIFICATION REFERENCE		UNIFORM STANDARD DRAWINGS CLARK COUNTY AREA	
623	TRAFFIC SIGNALS & STREETLIGHTING	STREETLIGHT LOCATIONS AT INTERSECTIONS 60'/60' RIGHT-OF-WAY (EXCEPT CLARK COUNTY & HENDERSON)	
		DATE 2-08-07	DWG. NO. 308

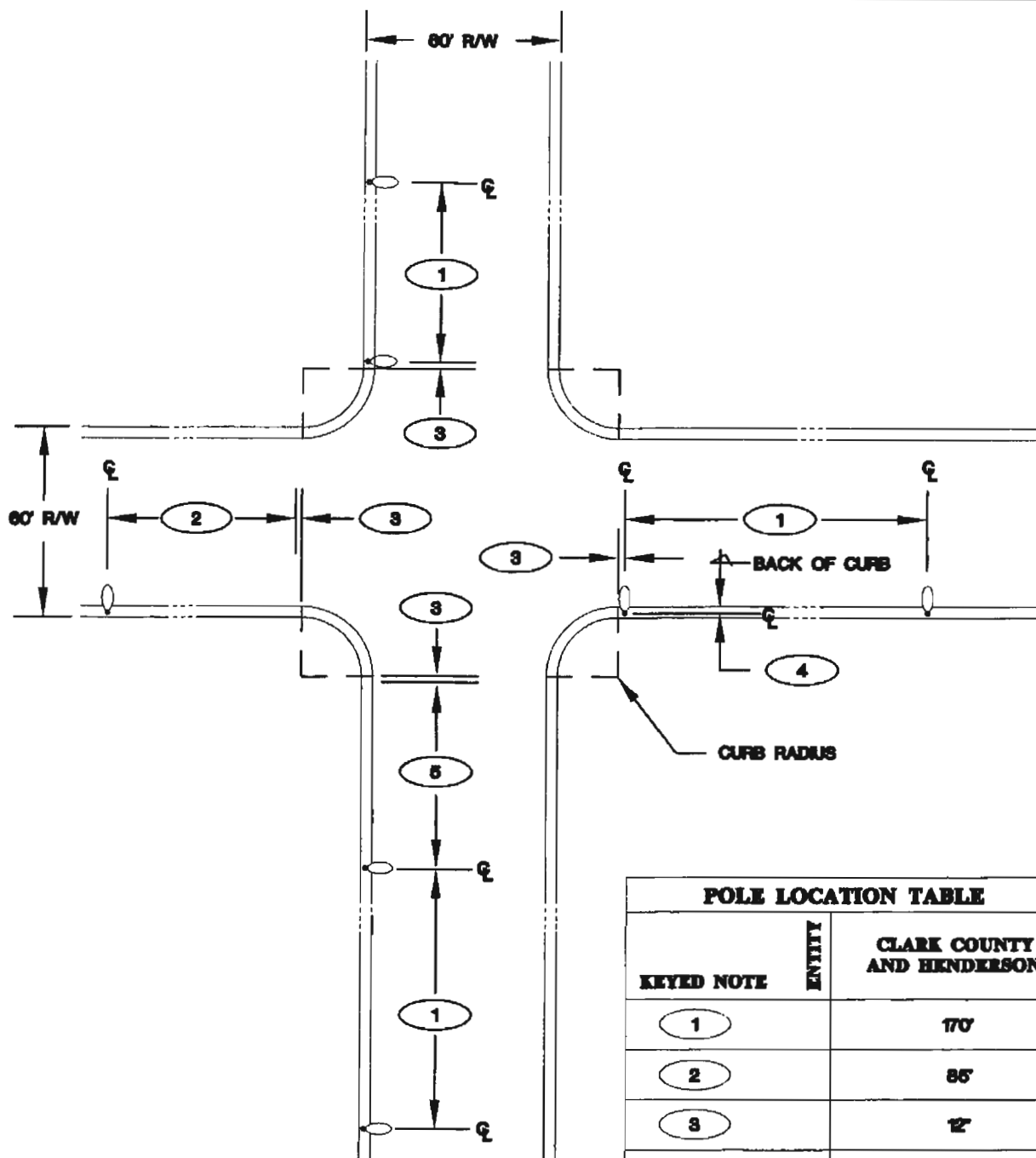

NOTE:
SEE GENERAL NOTES STANDARD DRAWING NO. 300.

• PROFESSIONAL ELECTRICAL ENGINEER STAMP ON FILE.

SPECIFICATION REFERENCE		UNIFORM STANDARD DRAWINGS CLARK COUNTY AREA	
623	TRAFFIC SIGNALS & STREETLIGHTING	CLARK COUNTY & HENDERSON ONLY	
		STREETLIGHT LOCATIONS AT INTERSECTIONS 60'/60' RIGHT-OF-WAY	
		DATE 2-08-07	DWG. NO. 308.1

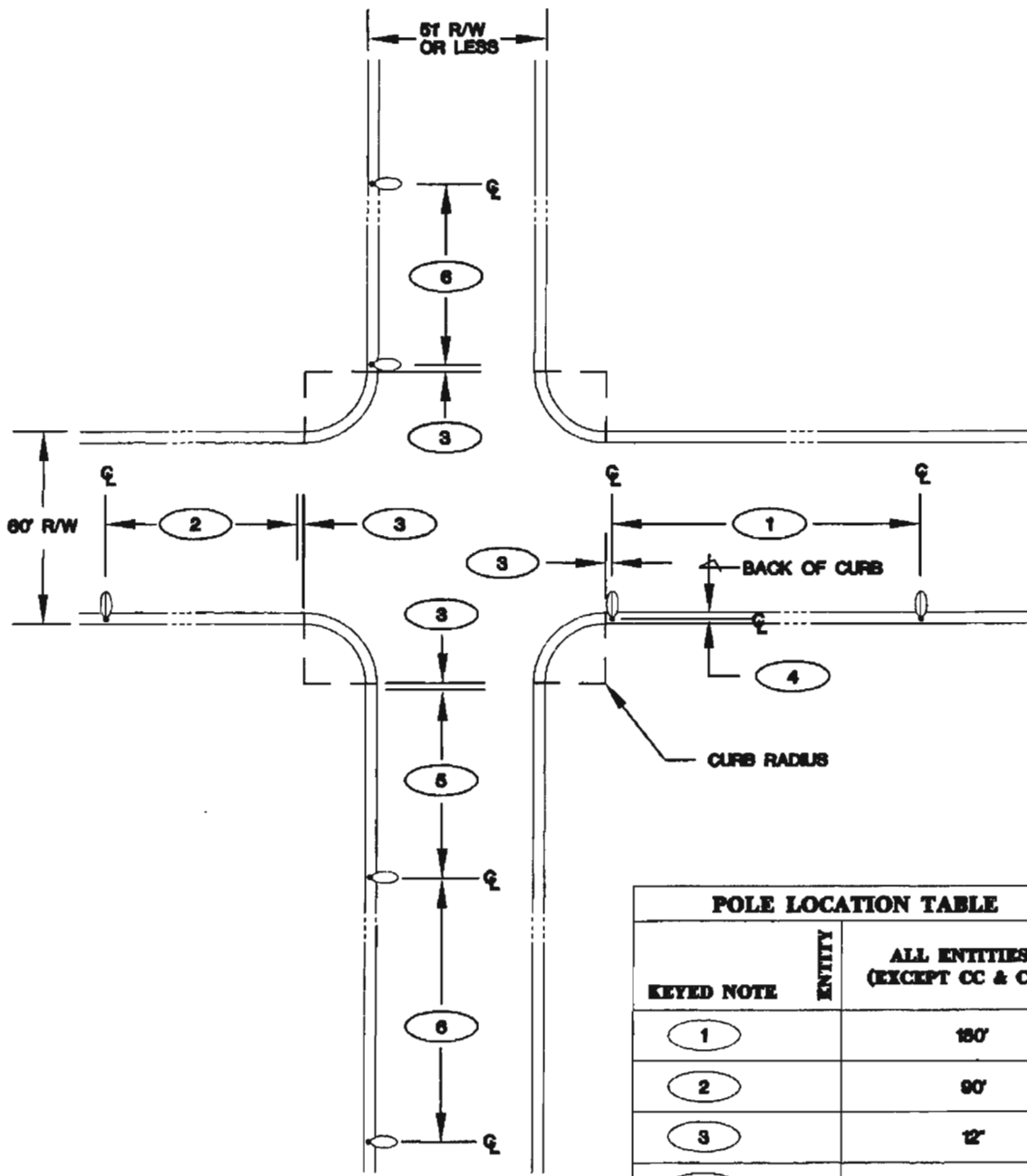

NOTE:
SEE GENERAL NOTES STANDARD DRAWING NO. 300.

POLE LOCATION TABLE	
KEYED NOTE	ENTITY ALL ENTITIES (EXCEPT CC & COH)
1	180'
2	90'
3	12'
4	(SEE DRAWING NO. 320)
5	85'
6	170'

• PROFESSIONAL ELECTRICAL ENGINEER STAMP ON FILE

SPECIFICATION REFERENCE		UNIFORM STANDARD DRAWINGS CLARK COUNTY AREA		
623	TRAFFIC SIGNALS & STREETLIGHTING	STREETLIGHT LOCATIONS AT INTERSECTIONS 60'/51' OR LESS RIGHT-OF-WAY (EXCEPT CLARK COUNTY & HENDERSON)		
		DATE 2-08-07	DWG. NO. 309	PAGE NO. 69

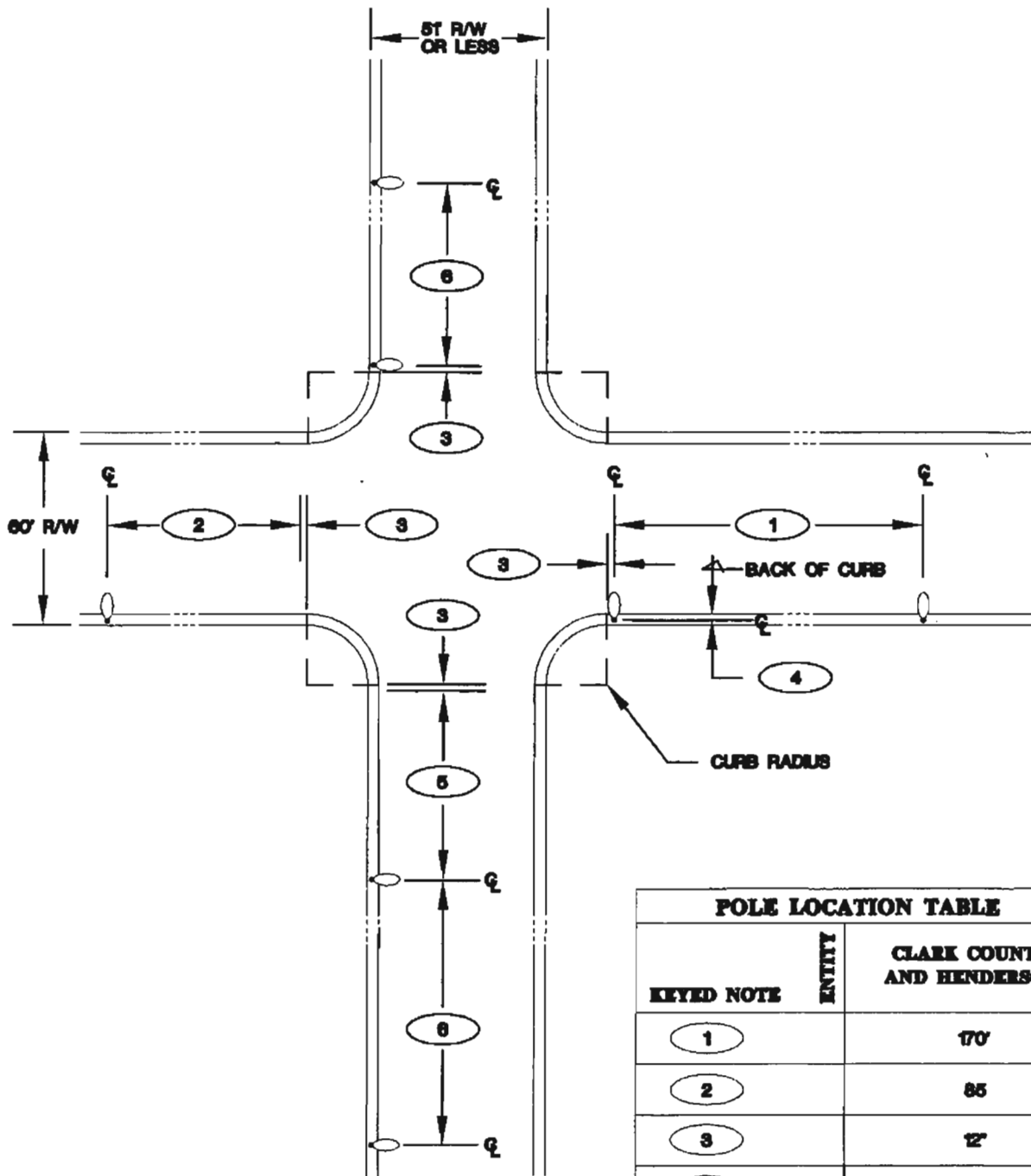

NOTE:

SEE GENERAL NOTES STANDARD DRAWING NO. 300.

• PROFESSIONAL ELECTRICAL ENGINEER STAMP ON FILE.

POLE LOCATION TABLE	
KEYED NOTE	ENTITY CLARK COUNTY AND HENDERSON
1	17'
2	85
3	12'
4	(SEE DRAWING NO. 320)
5	85
6	17'

SPECIFICATION REFERENCE		UNIFORM STANDARD DRAWINGS CLARK COUNTY AREA	
623	TRAFFIC SIGNALS & STREETLIGHTING	CLARK COUNTY & HENDERSON ONLY	
		STREETLIGHT LOCATIONS AT INTERSECTIONS 60'/51' OR LESS RIGHT-OF-WAY	
		DATE 2-08-07	DWG. NO. 309.1

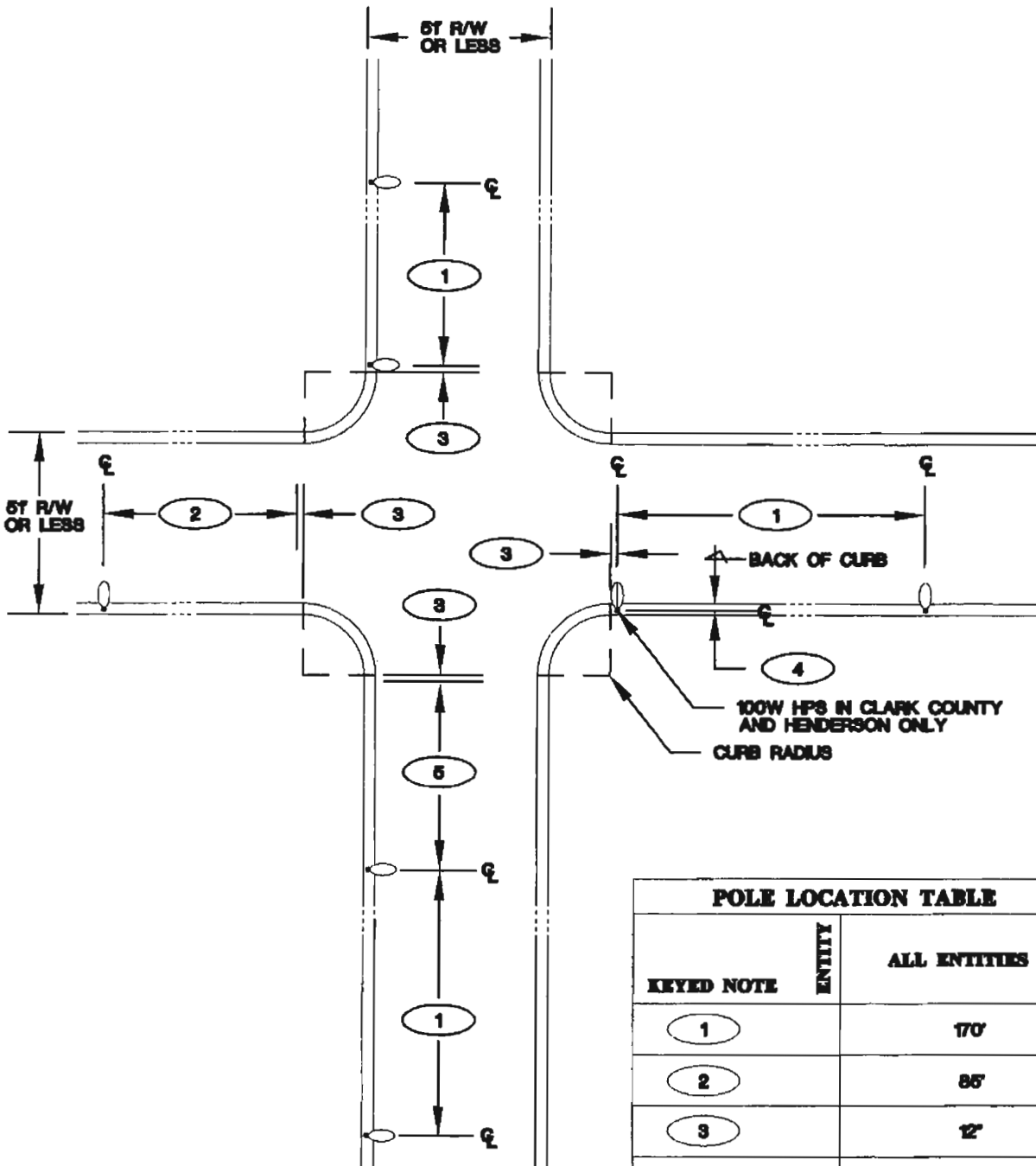

POLE LOCATION TABLE	
KEYED NOTE	ENTITY
1	ALL ENTITIES
2	170'
3	85'
4	12'
5	(SEE DRAWING NO. 320)
	85'

NOTE:
SEE GENERAL NOTES STANDARD DRAWING NO. 300.

• PROFESSIONAL ELECTRICAL ENGINEER STAMP ON FILE.

SPECIFICATION REFERENCE		UNIFORM STANDARD DRAWINGS CLARK COUNTY AREA	
623	TRAFFIC SIGNALS & STREETLIGHTING	STREETLIGHT LOCATIONS AT INTERSECTIONS 5' OR LESS/5' OR LESS RIGHT-OF-WAY	
		DATE 2-08-07	DWG. NO. 310

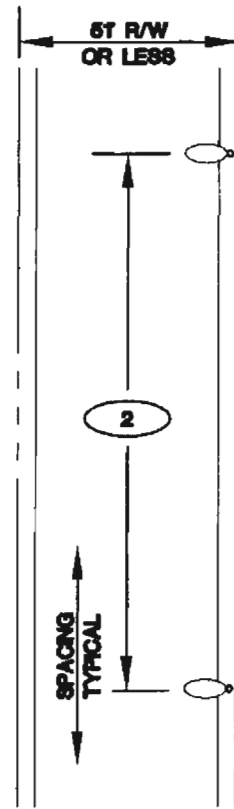
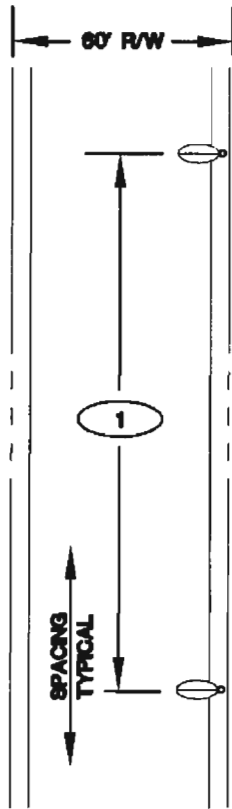

NOTES:

1. SEE GENERAL NOTES STANDARD DRAWING NO. 300.

POLE LOCATION TABLE		
KEYED NOTE	ENTITY	ALL ENTITIES (EXCEPT CC & COH)
1		180'
2		170'

• PROFESSIONAL ELECTRICAL ENGINEER STAMP ON FILE.

SPECIFICATION REFERENCE		UNIFORM STANDARD DRAWINGS CLARK COUNTY AREA	
623	TRAFFIC SIGNALS & STREETLIGHTING	STREETLIGHT STANDARDS MAXIMUM SPACING (60 FT. OR LESS RIGHT-OF-WAY) (EXCEPT CLARK COUNTY & HENDERSON)	
		DATE 2-08-07	DWG. NO. 311A

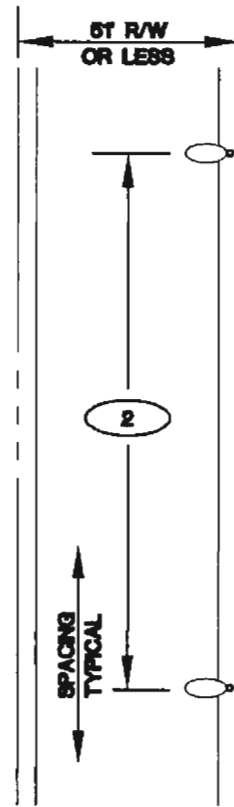
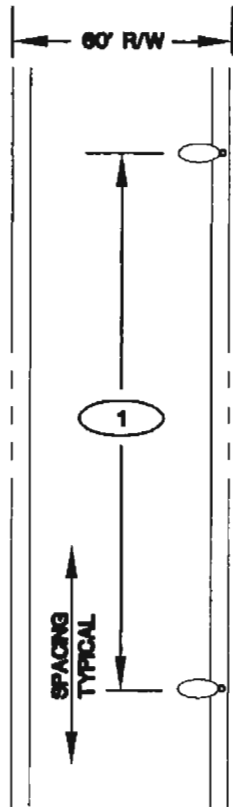

NOTES:

1. SEE GENERAL NOTES STANDARD DRAWING NO. 300.

POLE LOCATION TABLE	
KEYED NOTE	ENTITY CLARK COUNTY & HENDERSON
1	170'
2	170'

• PROFESSIONAL ELECTRICAL ENGINEER STAMP ON FILE

SPECIFICATION REFERENCE		UNIFORM STANDARD DRAWINGS CLARK COUNTY AREA	
623	TRAFFIC SIGNALS & STREETLIGHTING	CLARK COUNTY & HENDERSON ONLY	
		STREETLIGHT STANDARDS MAXIMUM SPACING (60 FT. OR LESS RIGHT-OF-WAY)	
		DATE 2-08-07	DWG. NO. 311A

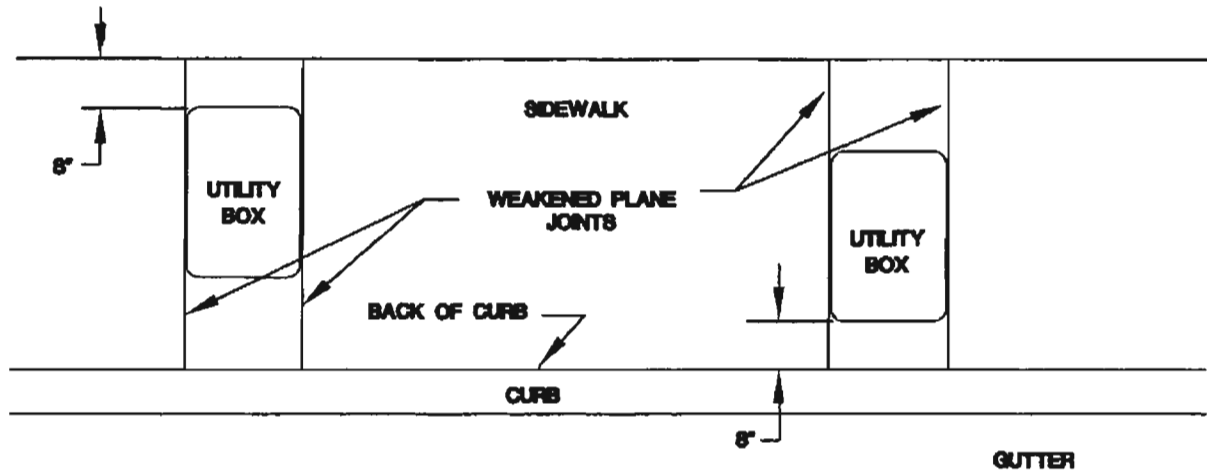

UTILITY BOXES IN SIDEWALK

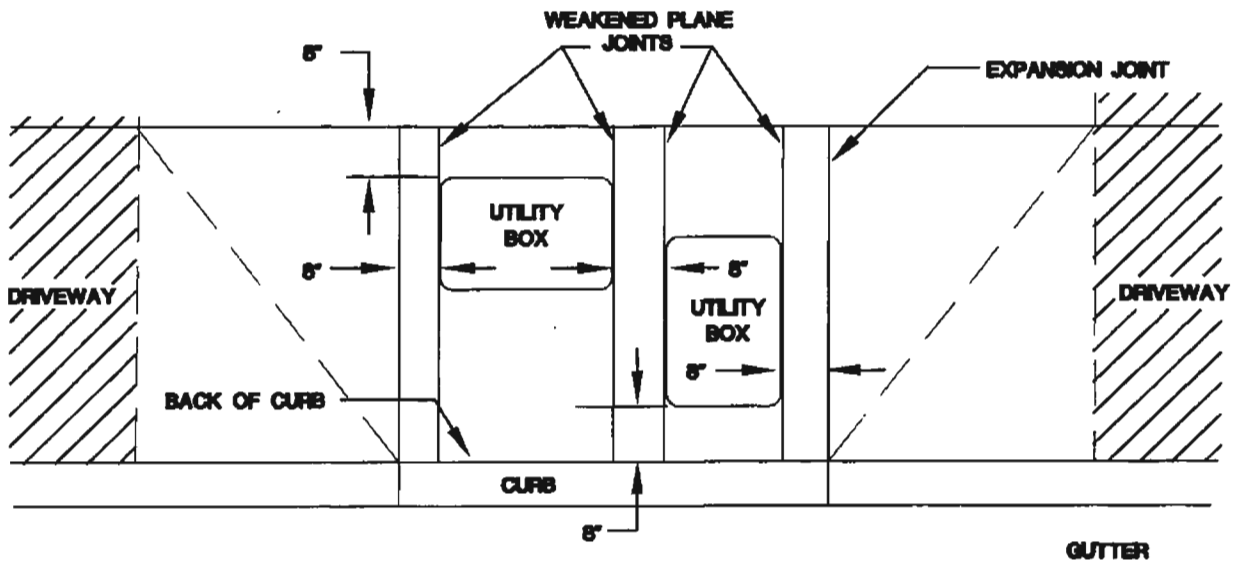

UTILITY BOXES BETWEEN DRIVEWAYS

NOTE:

1. PROVIDE A MINIMUM OF 8" AROUND ALL BOXES. ANY BOX SHALL NOT BE PLACED WITHIN 3'-3" OF FIRE HYDRANTS IN DRIVEWAYS OR DRIVEWAY APRONS. THIS DRAWING IS NOT INTENDED TO LIMIT THE NUMBER OF BOXES BETWEEN DRIVEWAYS TO TWO.
2. FOR WATER SERVICE BOXES, REFER TO UDACS PLATE 1A-1D.

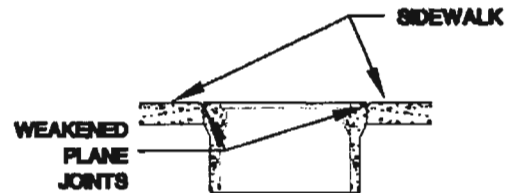

TYPICAL SECTION

SPECIFICATION REFERENCE		UNIFORM STANDARD DRAWINGS CLARK COUNTY AREA	
605	REINFORCING STEEL		
623	TRAFFIC SIGNALS & STREETLIGHTING	UTILITY PULL BOX LOCATIONS SIDEWALK AND BETWEEN DRIVEWAYS	
		DATE 04-12-07	DWG. NO. 328

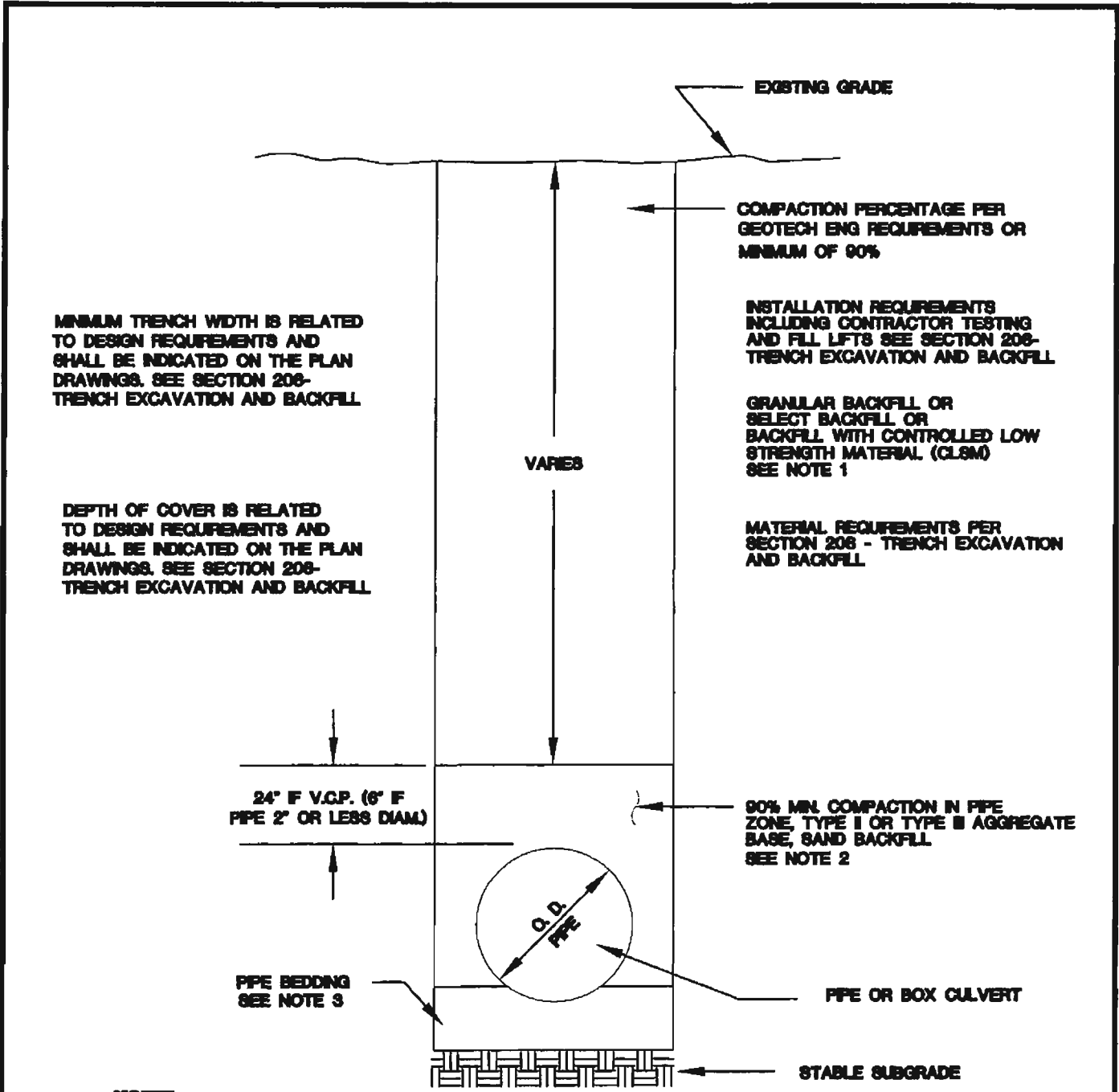

MINIMUM TRENCH WIDTH IS RELATED TO DESIGN REQUIREMENTS AND SHALL BE INDICATED ON THE PLAN DRAWINGS. SEE SECTION 208-TRENCH EXCAVATION AND BACKFILL

DEPTH OF COVER IS RELATED TO DESIGN REQUIREMENTS AND SHALL BE INDICATED ON THE PLAN DRAWINGS. SEE SECTION 208-TRENCH EXCAVATION AND BACKFILL

EXISTING GRADE

COMPACTION PERCENTAGE PER GEOTECH ENG REQUIREMENTS OR MINIMUM OF 90%

INSTALLATION REQUIREMENTS INCLUDING CONTRACTOR TESTING AND FILL LIFTS SEE SECTION 208-TRENCH EXCAVATION AND BACKFILL

GRANULAR BACKFILL OR SELECT BACKFILL OR BACKFILL WITH CONTROLLED LOW STRENGTH MATERIAL (CLSM) SEE NOTE 1

MATERIAL REQUIREMENTS PER SECTION 208 - TRENCH EXCAVATION AND BACKFILL

VARIES

24" F V.C.P. (6" F PIPE 2" OR LESS DIAM.)

90% MIN. COMPACTION IN PIPE ZONE, TYPE II OR TYPE III AGGREGATE BASE, SAND BACKFILL SEE NOTE 2

PIPE BEDDING SEE NOTE 3

PIPE OR BOX CULVERT

STABLE SUBGRADE

NOTES:

1. NO STONES OR LUMPS GREATER THAN 3" PERMITTED IN TRENCH 2' OR LESS IN WIDTH.
2. TRENCH WIDTH, BEDDING, SUBGRADE AND PIPE ZONE REQUIREMENTS FOR UTILITY INSTALLATIONS SHALL CONFORM TO THE RESPECTIVE AGENCY REQUIREMENTS.
3. CRUSHED ROCK MAY BE USED FOR PIPE BEDDING ONLY IF MATERIAL USE HAS BEEN SPECIFICALLY APPROVED BY THE GOVERNING AGENCY. SEE STANDARD DRAWING NO. 505 FOR PIPE BEDDING METHODS.
4. LAS VEGAS VALLEY WATER DISTRICT REQUIRES PIPE BEDDING AND BACKFILL WITHIN THE PIPE ZONE TO BE OF THE SAME MATERIAL.
5. A ONE INCH MAXIMUM LEVELING COURSE IS PERMITTED WHEN APPROVED BY THE ENGINEER.

SPECIFICATION REFERENCE		UNIFORM STANDARD DRAWINGS CLARK COUNTY AREA		
208	TRENCH EXCAVATION & BACKFILL	METHOD B FOR RIGID AND FLEXIBLE PIPE TRENCH BACKFILL - UNPAVED AREAS AND AREAS OUTSIDE EXISTING OR FUTURE PROPOSED STREET RIGHT-OF-WAY		
302	AGGREGATE BASE COURSES			
		DATE 11-9-06	DWG. NO. 502	PAGE

MINIMUM TRENCH WIDTH IS RELATED TO DESIGN REQUIREMENTS AND SHALL BE INDICATED ON THE PLAN DRAWINGS. SEE SECTION 208- TRENCH EXCAVATION AND BACKFILL

DEPTH OF COVER IS RELATED TO DESIGN REQUIREMENTS AND SHALL BE INDICATED ON THE PLAN DRAWINGS. SEE SECTION 208- TRENCH EXCAVATION AND BACKFILL

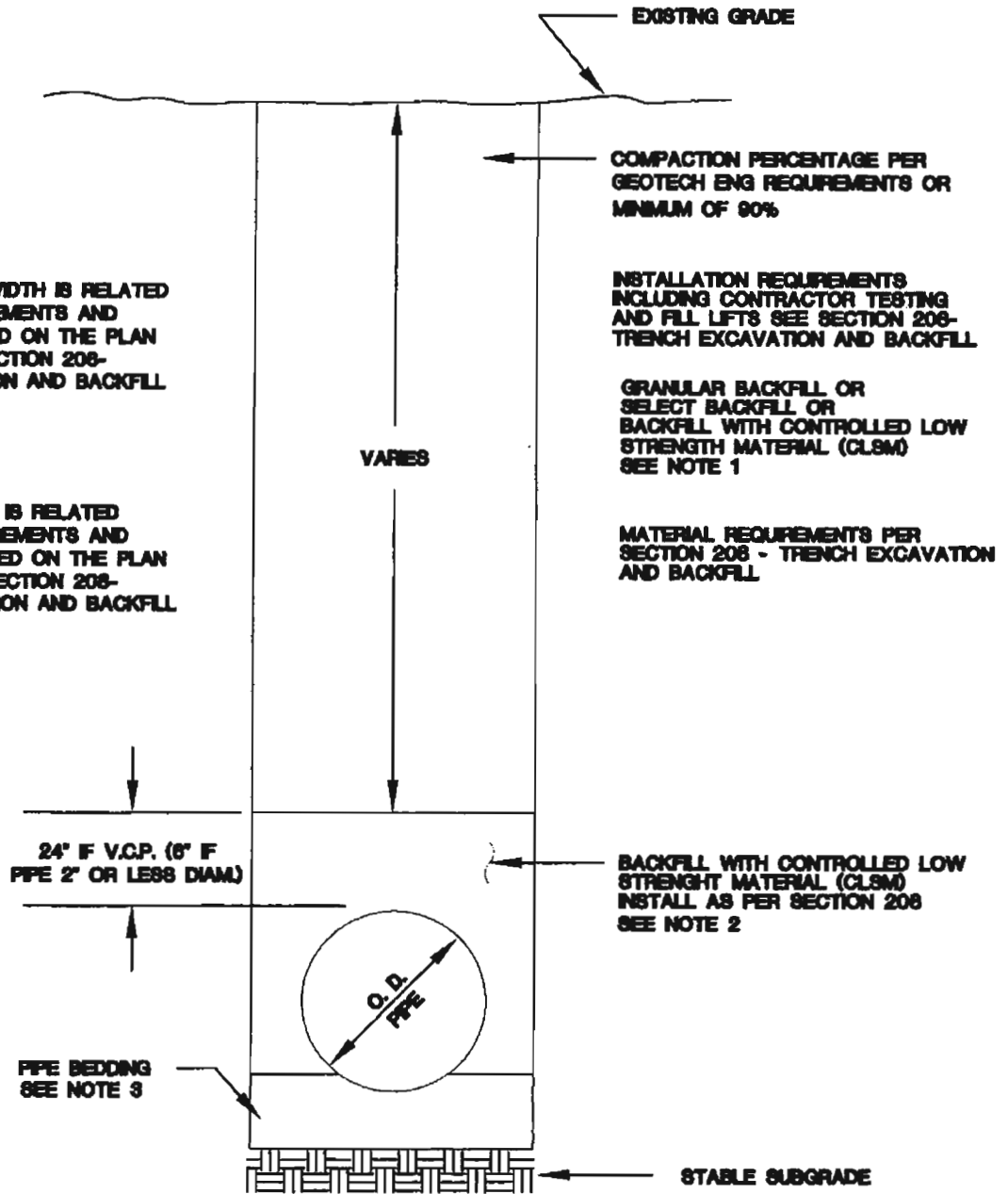

NOTES:

1. NO STONES OR LUMPS GREATER THAN 5" PERMITTED IN TRENCH 2' OR LESS IN WIDTH.
2. TRENCH WIDTH, BEDDING, SUBGRADE AND PIPE ZONE REQUIREMENTS FOR UTILITY INSTALLATIONS SHALL CONFORM TO THE RESPECTIVE AGENCY REQUIREMENTS.
3. CRUSHED ROCK MAY BE USED FOR PIPE BEDDING ONLY IF MATERIAL USE HAS BEEN SPECIFICALLY APPROVED BY THE GOVERNING AGENCY. SEE STANDARD DRAWING NO. 505 FOR PIPE BEDDING METHODS.
4. LAS VEGAS VALLEY WATER DISTRICT REQUIRES PIPE BEDDING AND BACKFILL WITHIN THE PIPE ZONE TO BE OF THE SAME MATERIAL.
5. A ONE INCH MAXIMUM LEVELING COURSE IS PERMITTED WHEN APPROVED BY THE ENGINEER.

SPECIFICATION REFERENCE		UNIFORM STANDARD DRAWINGS CLARK COUNTY AREA		
208	TRENCH EXCAVATION & BACKFILL	METHOD A FOR FLEXIBLE PIPE TRENCH BACKFILL - UNPAVED AREAS AND AREAS OUTSIDE EXISTING OR FUTURE PROPOSED STREET RIGHT-OF-WAY		
302	AGGREGATE BASE COURSES			
		DATE 11-9-08	DWG. NO. 502A	PAGE

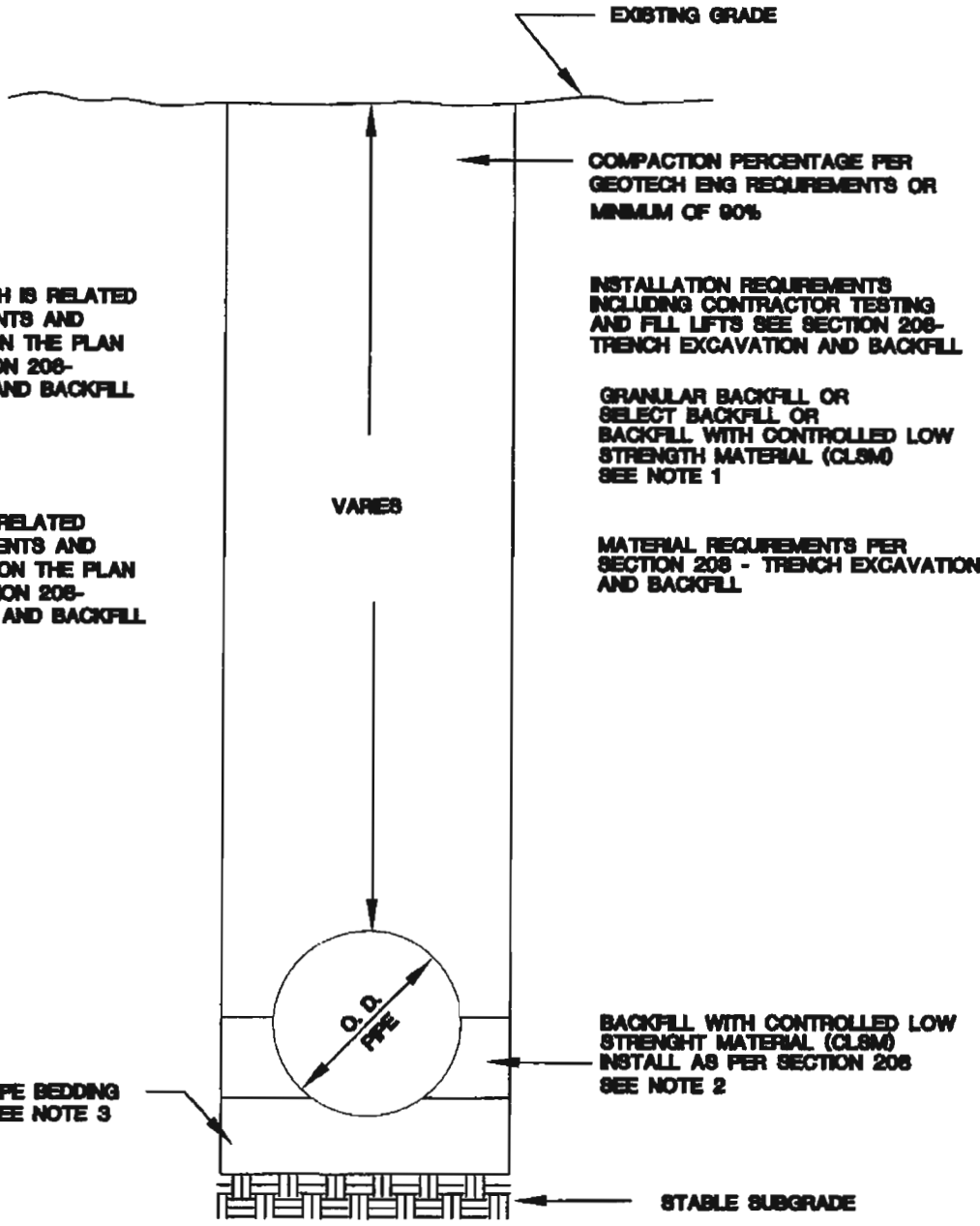

MINIMUM TRENCH WIDTH IS RELATED TO DESIGN REQUIREMENTS AND SHALL BE INDICATED ON THE PLAN DRAWINGS. SEE SECTION 208-TRENCH EXCAVATION AND BACKFILL

DEPTH OF COVER IS RELATED TO DESIGN REQUIREMENTS AND SHALL BE INDICATED ON THE PLAN DRAWINGS. SEE SECTION 208-TRENCH EXCAVATION AND BACKFILL

NOTES:

1. NO STONES OR LUMPS GREATER THAN 3" PERMITTED IN TRENCH 2' OR LESS IN WIDTH.
2. TRENCH WIDTH, BEDDING, SUBGRADE AND PIPE ZONE REQUIREMENTS FOR UTILITY INSTALLATIONS SHALL CONFORM TO THE RESPECTIVE AGENCY REQUIREMENTS.
3. CRUSHED ROCK MAY BE USED FOR PIPE BEDDING ONLY IF MATERIAL USE HAS BEEN SPECIFICALLY APPROVED BY THE GOVERNING AGENCY. SEE STANDARD DRAWING NO. 505 FOR PIPE BEDDING METHODS.
4. LAS VEGAS VALLEY WATER DISTRICT REQUIRES PIPE BEDDING AND BACKFILL WITHIN THE PIPE ZONE TO BE OF THE SAME MATERIAL.
5. A ONE INCH MAXIMUM LEVELING COURSE IS PERMITTED WHEN APPROVED BY THE ENGINEER.

SPECIFICATION REFERENCE		UNIFORM STANDARD DRAWINGS CLARK COUNTY AREA	
208	TRENCH EXCAVATION & BACKFILL	METHOD A FOR RIGID PIPE TRENCH BACKFILL - UNPAVED AREAS AND AREAS OUTSIDE EXISTING OR FUTURE PROPOSED STREET RIGHT-OF-WAY	
302	AGGREGATE BASE COURSES		
		DATE 11-9-08	DWG. NO. 502B
		PAGE	

NEW PAVEMENT SURFACE

SUBGRADE

MINIMUM TRENCH WIDTH IS RELATED TO DESIGN REQUIREMENTS AND SHALL BE INDICATED ON THE PLAN DRAWINGS. SEE SECTION 208-TRENCH EXCAVATION AND BACKFILL

DEPTH OF COVER IS RELATED TO DESIGN REQUIREMENTS AND SHALL BE INDICATED ON THE PLAN DRAWINGS. SEE SECTION 208-TRENCH EXCAVATION AND BACKFILL

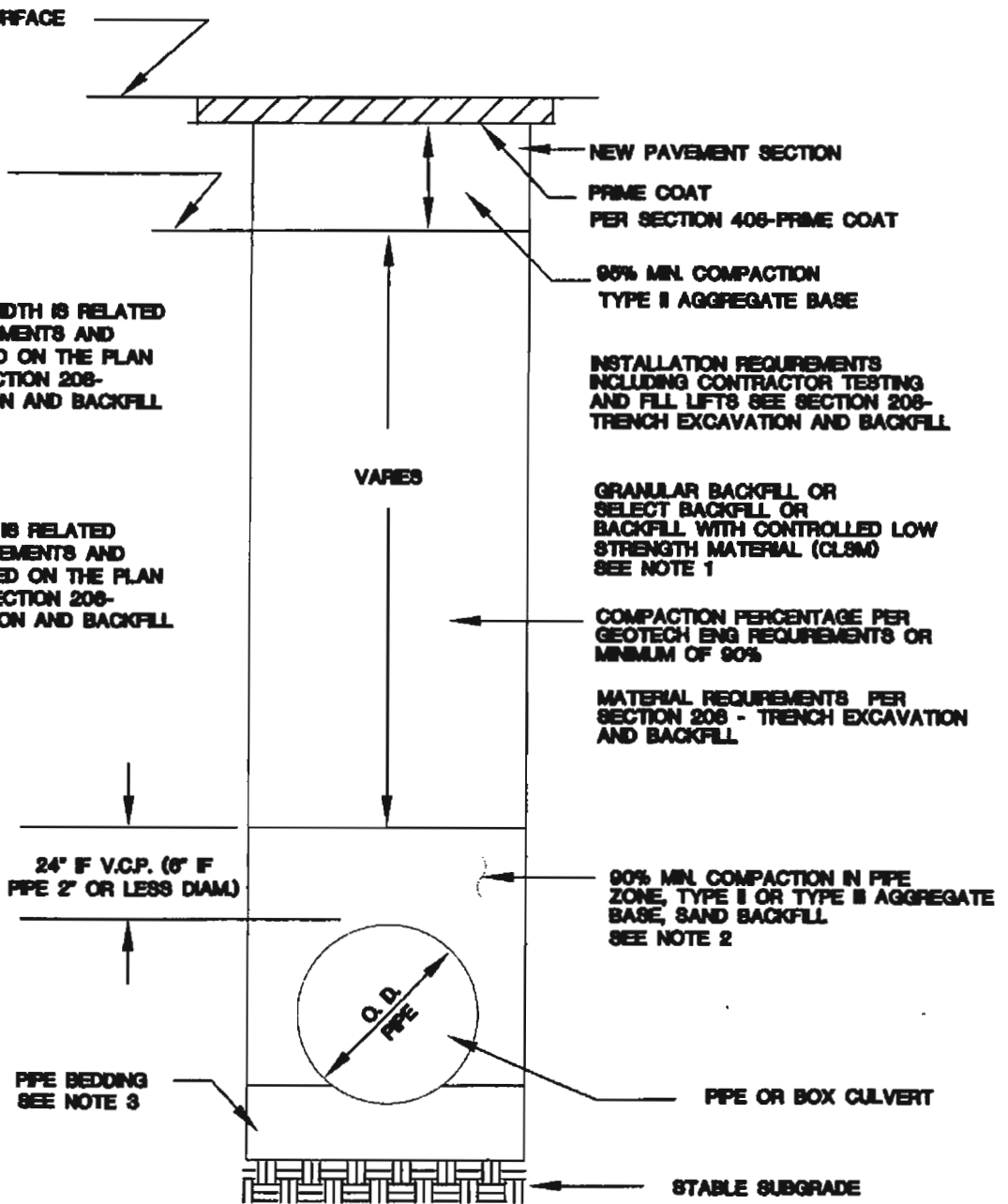

NEW PAVEMENT SECTION
PRIME COAT
PER SECTION 406-PRIME COAT

95% MIN. COMPACTION
TYPE II AGGREGATE BASE

INSTALLATION REQUIREMENTS
INCLUDING CONTRACTOR TESTING
AND FILL LIFTS SEE SECTION 208-
TRENCH EXCAVATION AND BACKFILL

GRANULAR BACKFILL OR
SELECT BACKFILL OR
BACKFILL WITH CONTROLLED LOW
STRENGTH MATERIAL (CLSM)
SEE NOTE 1

COMPACTION PERCENTAGE PER
GEOTECH ENG REQUIREMENTS OR
MINIMUM OF 90%

MATERIAL REQUIREMENTS PER
SECTION 208 - TRENCH EXCAVATION
AND BACKFILL

90% MIN. COMPACTION IN PIPE
ZONE, TYPE II OR TYPE III AGGREGATE
BASE, SAND BACKFILL
SEE NOTE 2

PIPE OR BOX CULVERT

STABLE SUBGRADE

NOTES:

1. NO STONES OR LUMPS GREATER THAN 3" PERMITTED IN TRENCH 2' OR LESS IN WIDTH.
2. TRENCH WIDTH, BEDDING, SUBGRADE AND PIPE ZONE REQUIREMENTS FOR UTILITY INSTALLATIONS SHALL CONFORM TO THE RESPECTIVE AGENCY REQUIREMENTS.
3. CRUSHED ROCK MAY BE USED FOR PIPE BEDDING ONLY IF MATERIAL USE HAS BEEN SPECIFICALLY APPROVED BY THE GOVERNING AGENCY. SEE STANDARD DRAWING NO. 505 FOR PIPE BEDDING METHODS.
4. LAS VEGAS VALLEY WATER DISTRICT REQUIRES PIPE BEDDING AND BACKFILL WITHIN THE PIPE ZONE TO BE OF THE SAME MATERIAL.
5. A ONE INCH MAXIMUM LEVELING COURSE IS PERMITTED WHEN APPROVED BY THE ENGINEER.

SPECIFICATION REFERENCE

208	TRENCH EXCAVATION & BACKFILL
302	AGGREGATE BASE COURSES

**UNIFORM STANDARD DRAWINGS
CLARK COUNTY AREA**

**METHOD B FOR FOR RIGID AND FLEXIBLE PIPE
TRENCH BACKFILL - PAVED AREAS AND
AREAS OUTSIDE EXISTING OR FUTURE
PROPOSED STREET RIGHT-OF-WAY**

NEW PAVEMENT SURFACE

SUBGRADE

MINIMUM TRENCH WIDTH IS RELATED TO DESIGN REQUIREMENTS AND SHALL BE INDICATED ON THE PLAN DRAWINGS. SEE SECTION 208-TRENCH EXCAVATION AND BACKFILL

DEPTH OF COVER IS RELATED TO DESIGN REQUIREMENTS AND SHALL BE INDICATED ON THE PLAN DRAWINGS. SEE SECTION 208-TRENCH EXCAVATION AND BACKFILL

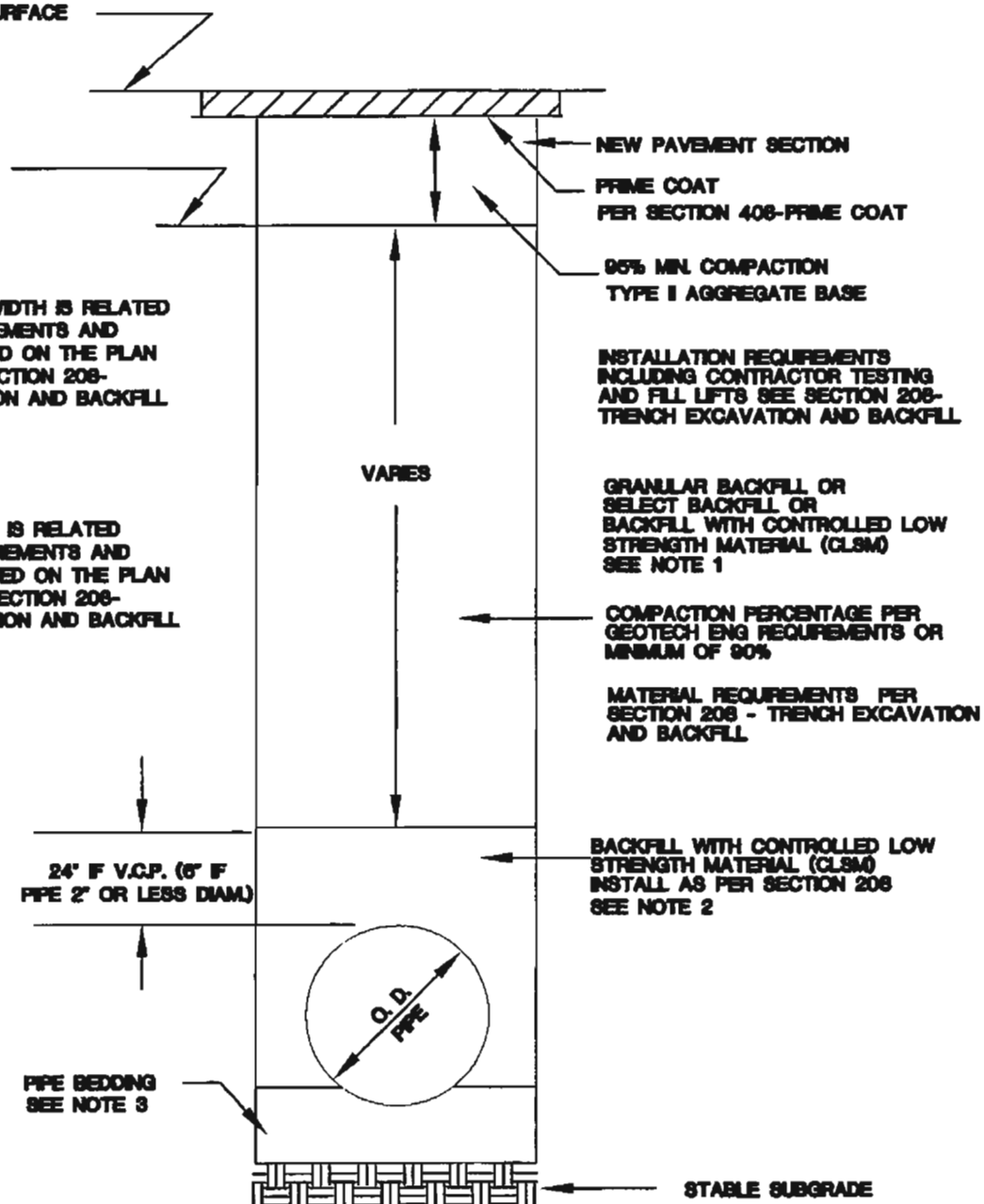

NOTES:

1. NO STONES OR LUMPS GREATER THAN 3" PERMITTED IN TRENCH 2' OR LESS IN WIDTH.
2. TRENCH WIDTH, BEDDING, SUBGRADE AND PIPE ZONE REQUIREMENTS FOR UTILITY INSTALLATIONS SHALL CONFORM TO THE RESPECTIVE AGENCY REQUIREMENTS.
3. CRUSHED ROCK MAY BE USED FOR PIPE BEDDING ONLY IF MATERIAL USE HAS BEEN SPECIFICALLY APPROVED BY THE GOVERNING AGENCY. SEE STANDARD DRAWING NO. 505 FOR PIPE BEDDING METHODS.
4. LAS VEGAS VALLEY WATER DISTRICT REQUIRES PIPE BEDDING AND BACKFILL WITHIN THE PIPE ZONE TO BE OF THE SAME MATERIAL.
5. A ONE INCH MAXIMUM LEVELING COURSE IS PERMITTED WHEN APPROVED BY THE ENGINEER.
6. CONTROLLED LOW STRENGTH MATERIALS (CLSM) SHALL BE USED IN THE UPPER 24" WITH RIGHT-OF-WAYS 80 FEET OR GREATER.

SPECIFICATION REFERENCE		UNIFORM STANDARD DRAWINGS CLARK COUNTY AREA		
208	TRENCH EXCAVATION & BACKFILL	METHOD A FOR FLEXIBLE PIPE TRENCH BACKFILL - PAVED AREAS AND AREAS OUTSIDE EXISTING OR FUTURE PROPOSED STREET RIGHT-OF-WAY		
302	AGGREGATE BASE COURSES			
		DATE 11-9-06	DWG. NO. 503A	PAGE

NEW PAVEMENT SURFACE

SUBGRADE

MINIMUM TRENCH WIDTH IS RELATED TO DESIGN REQUIREMENTS AND SHALL BE INDICATED ON THE PLAN DRAWINGS. SEE SECTION 208-TRENCH EXCAVATION AND BACKFILL

DEPTH OF COVER IS RELATED TO DESIGN REQUIREMENTS AND SHALL BE INDICATED ON THE PLAN DRAWINGS. SEE SECTION 208-TRENCH EXCAVATION AND BACKFILL

VARIES

NEW PAVEMENT SECTION

PRIME COAT
PER SECTION 408-PRIME COAT

95% MIN. COMPACTION
TYPE II AGGREGATE BASE

INSTALLATION REQUIREMENTS INCLUDING CONTRACTOR TESTING AND FILL LIFTS SEE SECTION 208-TRENCH EXCAVATION AND BACKFILL

GRANULAR BACKFILL OR SELECT BACKFILL OR BACKFILL WITH CONTROLLED LOW STRENGTH MATERIAL (CLSM) SEE NOTE 1

COMPACTION PERCENTAGE PER GEOTECH ENG REQUIREMENTS OR MINIMUM OF 90%

MATERIAL REQUIREMENTS PER SECTION 208 - TRENCH EXCAVATION AND BACKFILL

90% MIN. COMPACTION IN PIPE ZONE, TYPE II OR TYPE III AGGREGATE BASE, SAND BACKFILL, OR BACKFILL WITH CONTROLLED LOW STRENGTH MATERIAL (CLSM) SEE NOTE 2

BACKFILL WITH CONTROLLED LOW STRENGTH MATERIAL (CLSM) INSTALL AS PER SECTION 208 SEE NOTE 2

PIPE BEDDING
SEE NOTE 3

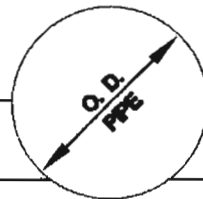

STABLE SUBGRADE

NOTES:

1. NO STONES OR LUMPS GREATER THAN 3" PERMITTED IN TRENCH 2' OR LESS IN WIDTH.
2. TRENCH WIDTH, BEDDING, SUBGRADE AND PIPE ZONE REQUIREMENTS FOR UTILITY INSTALLATIONS SHALL CONFORM TO THE RESPECTIVE AGENCY REQUIREMENTS.
3. CRUSHED ROCK MAY BE USED FOR PIPE BEDDING ONLY IF MATERIAL USE HAS BEEN SPECIFICALLY APPROVED BY THE GOVERNING AGENCY. SEE STANDARD DRAWING NO. 505 FOR PIPE BEDDING METHODS.
4. LAS VEGAS VALLEY WATER DISTRICT REQUIRES PIPE BEDDING AND BACKFILL WITHIN THE PIPE ZONE TO BE OF THE SAME MATERIAL.
5. A ONE INCH MAXIMUM LEVELING COURSE IS PERMITTED WHEN APPROVED BY THE ENGINEER.
6. CONTROLLED LOW STRENGTH MATERIALS (CLSM) SHALL BE USED IN THE UPPER 24" WITH RIGHT-OF-WAYS 80 FEET OR GREATER.

SPECIFICATION REFERENCE

208	TRENCH EXCAVATION & BACKFILL
302	AGGREGATE BASE COURSES

**UNIFORM STANDARD DRAWINGS
CLARK COUNTY AREA**

**METHOD A FOR RIGID PIPE
TRENCH BACKFILL - PAVED AREAS AND
AREAS OUTSIDE EXISTING OR FUTURE
PROPOSED STREET RIGHT-OF-WAY**

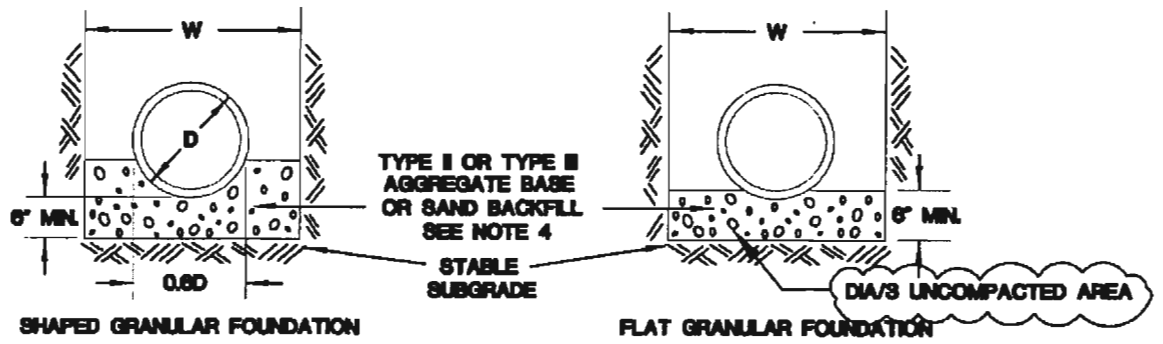

NORMAL BEDDING

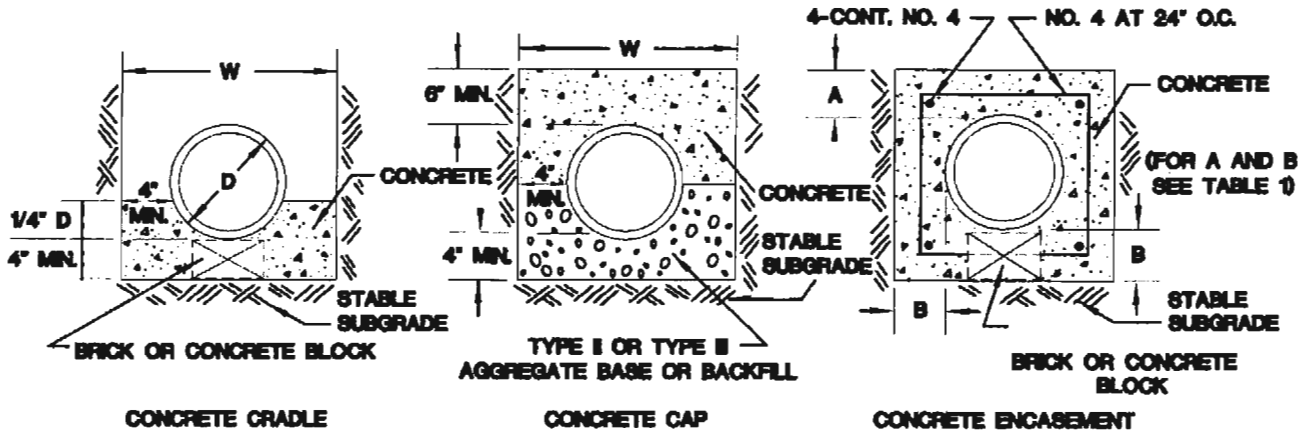

CONCRETE BEDDING

PIPE SIZE	PIPE		PIPE SIZE	PIPE	
	B	A		B	A
6"	4"	4"	24"	6"	6"
8"	4"	4"	27"	7"	6"
10"	4"	4"	30"	8"	6"
12"	4"	4"	33"	8"	6"
15"	4"	4"	36"	9"	6"
18"	5"	5"	39"	9"	6"
24"	5"	5"	42"	10"	6"

D = OUTSIDE DIAMETER OF PIPE
W = OUTSIDE DIAMETER OF PIPE + 24" MAXIMUM

NOTES:

1. PIPE BEDDING TO BE COMPACTED TO AT LEAST 90% OF MAXIMUM DENSITY. SUBGRADE SHALL CONFORM TO RESPECTIVE ENTITY REQUIREMENTS.
2. INDICATED THICKNESS OF BEDDING MATERIAL TO BE CONSTRUCTED UNDER THE BARREL. SUBGRADE TO BE EXCAVATED TO PROVIDE 2" CLEARANCE UNDER THE BELL.
3. OTHER BEDDING METHODS MAY BE SPECIFIED OR APPROVED.
4. CRUSHED ROCK MAY BE USED FOR PIPE BEDDING ONLY IF MATERIAL USE HAS BEEN SPECIFICALLY APPROVED BY THE GOVERNING AGENCY.

SPECIFICATION REFERENCE		UNIFORM STANDARD DRAWINGS CLARK COUNTY AREA		
208	TRENCH EXCAVATION & BACKFILL	PIPE TRENCH BEDDING METHODS		
302	AGGREGATE BASE COURSES			
501	CONCRETE			
505	REINFORCEMENT STEEL			
		DATE 11-9-08	DWG. NO. 505	PAGE NO. 125

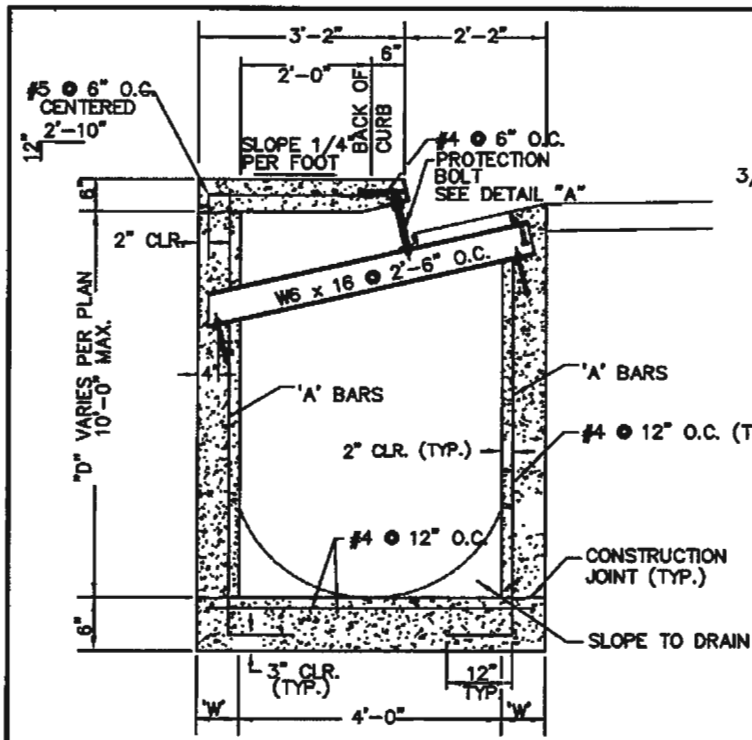

TYPE "CM2" DROP INLET SECTION

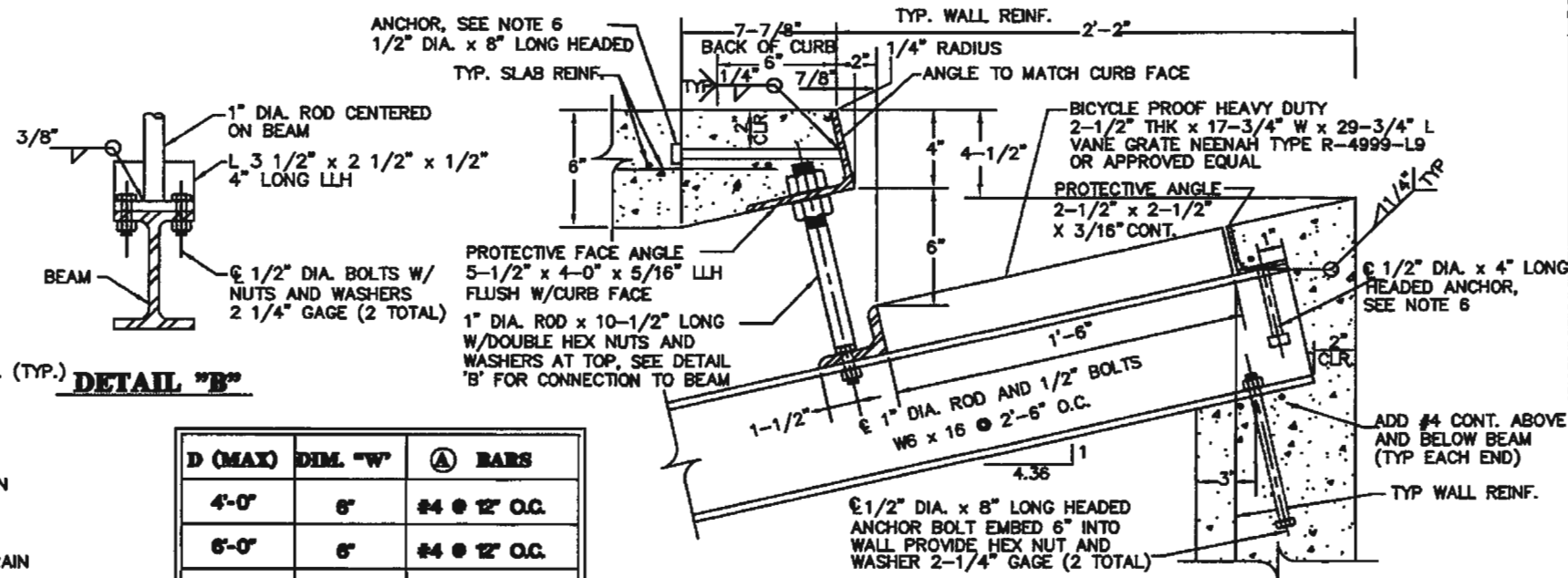

PROTECTIVE FACE & ROD - DETAIL "A"

D (MAX)	DIM. "W"	A BARS
4'-0"	6"	#4 @ 12" O.C.
6'-0"	6"	#4 @ 12" O.C.
8'-0"	6"	#5 @ 2" O.C.
10'-0"	6"	#5 @ 6" O.C.

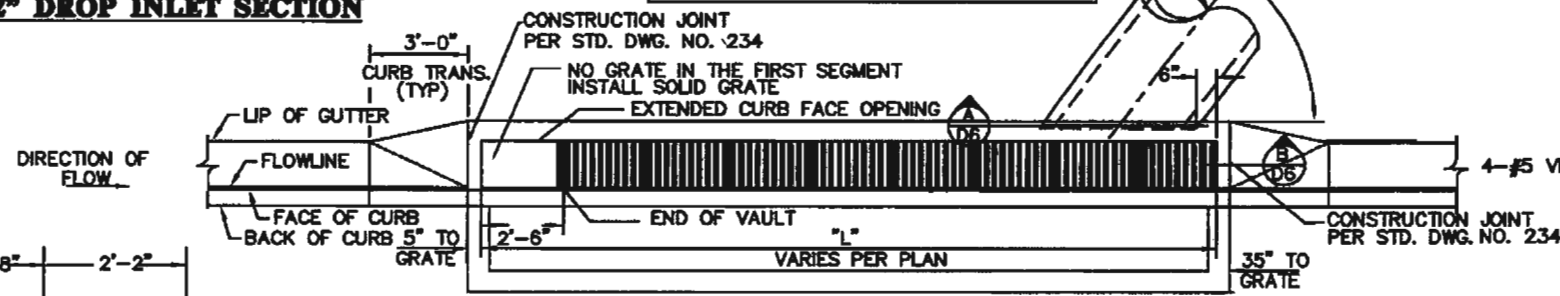

DROP INLET LAYOUT PLAN

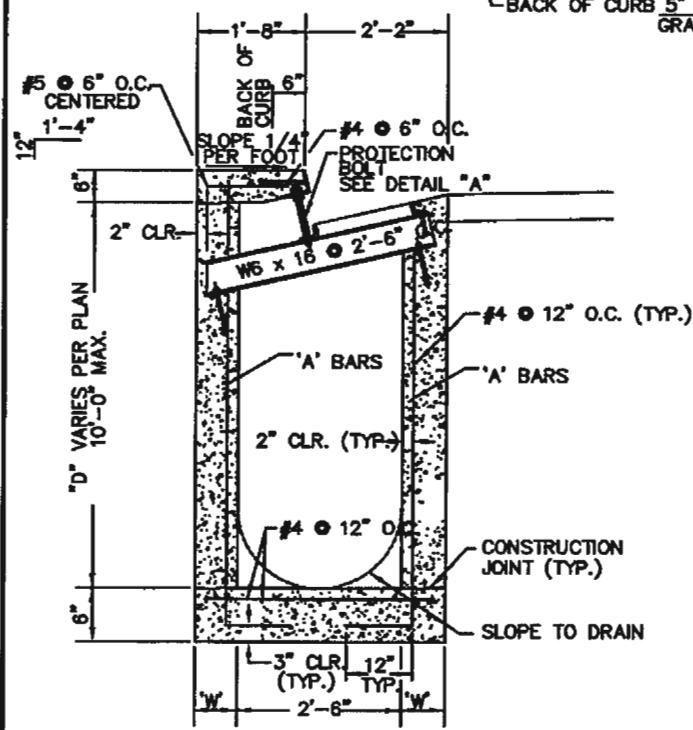

TYPE "DM2" DROP INLET SECTION

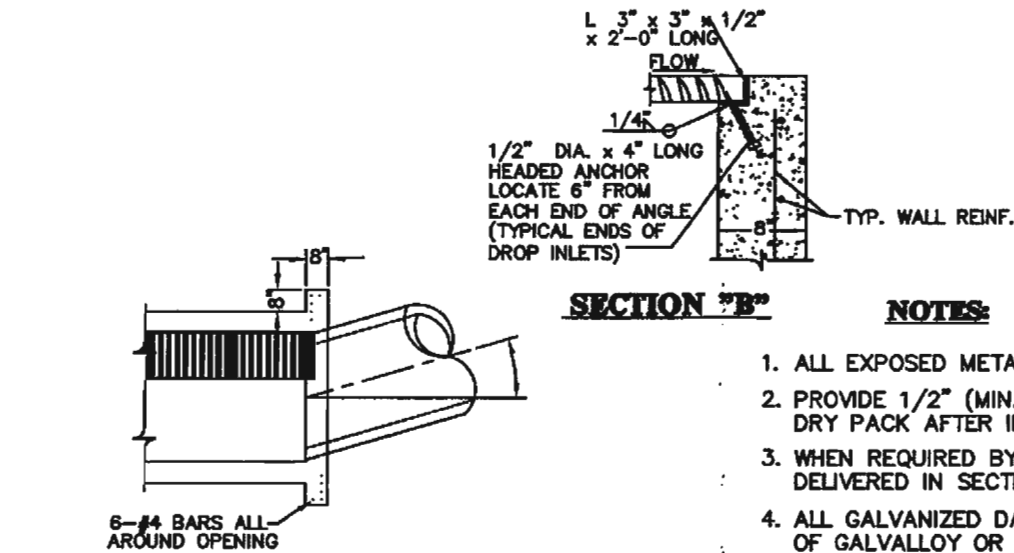

ALTERNATE CONNECTION DETAIL

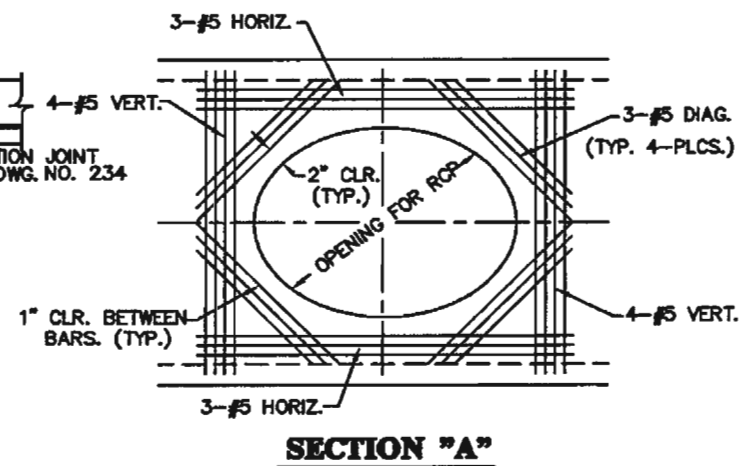

SECTION "A"

NOTES:

1. ALL EXPOSED METALS SHALL BE HOT DIP GALVANIZED AFTER FABRICATION.
2. PROVIDE 1/2" (MIN.) CLEARANCE ALL AROUND THE STEEL BEAM, DRY PACK AFTER INSTALLATION.
3. WHEN REQUIRED BY LENGTH OF OPENING, PLATE ANGLE MAY BE DELIVERED IN SECTIONS AND BUTT WELDED IN PLACE.
4. ALL GALVANIZED DAMAGED BY WELDING SHALL RECEIVE TWO COATS OF GALVALLOY OR EQUAL.
5. CONCRETE SHALL BE MODIFIED CLASS DA 4000 PSI, SEE SPECIAL PROVISIONS SECTION 501.
6. ANGLE ANCHORS SHALL BE EMBEDDED MIDPOINT IN EACH ENDWALL AND EVENLY SPACED, (MAXIMUM SPACING OF 2').

**UNIFORM STANDARD DRAWINGS
CLARK COUNTY AREA**

TYPE C-D MODIFIED DROP INLET

SPECIFICATION REFERENCE

CONCRETE	501
CONCRETE STRUCTURES	502
REINFORCING STEEL	505
STEEL	713

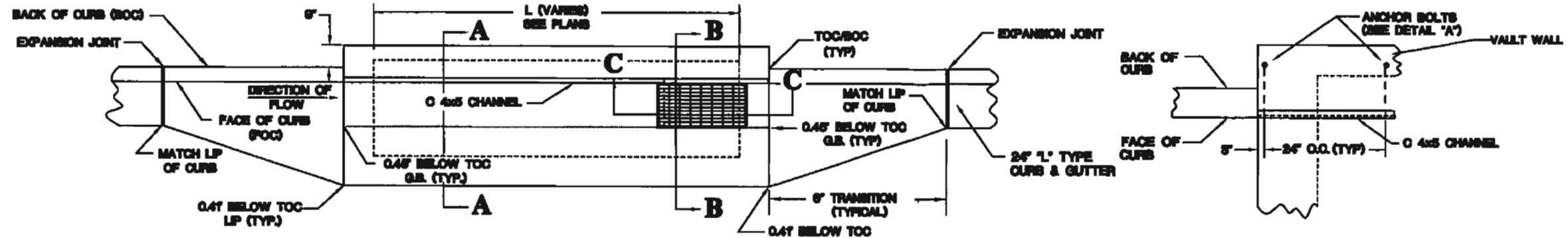

PLAN VIEW

DETAIL "B"

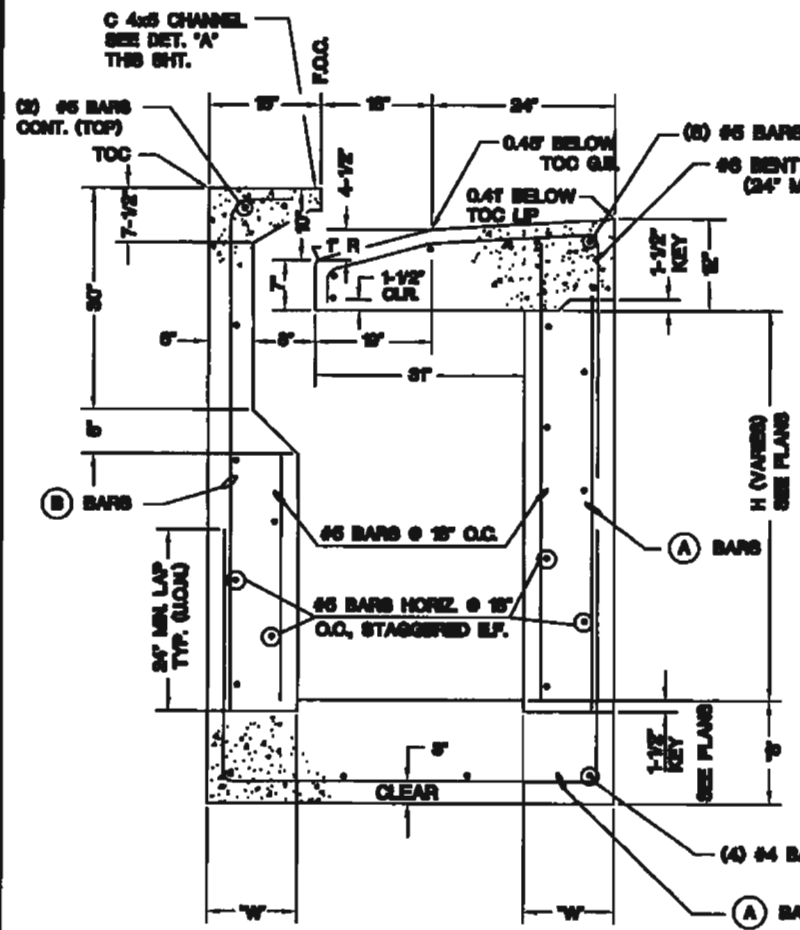

SECTION A-A

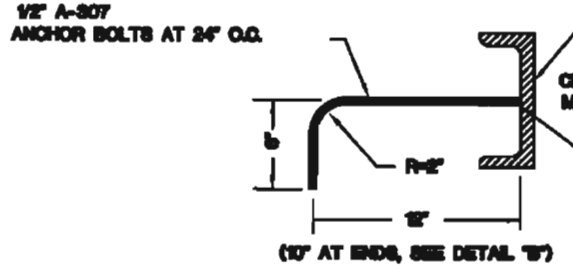

DETAIL "A"

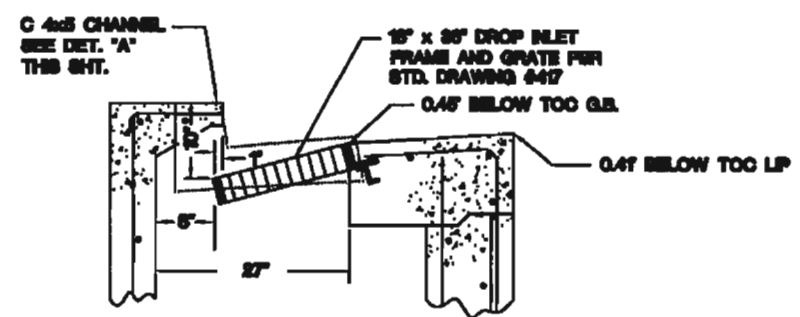

SECTION B-B

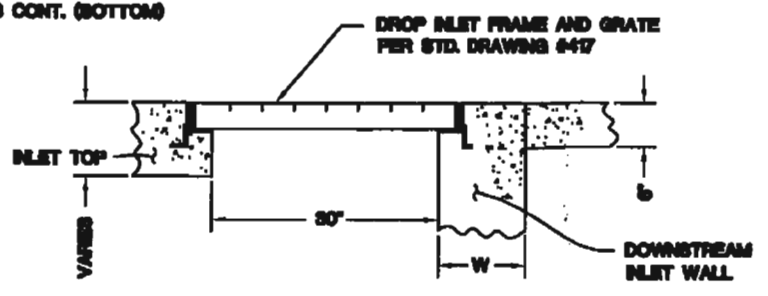

SECTION C-C

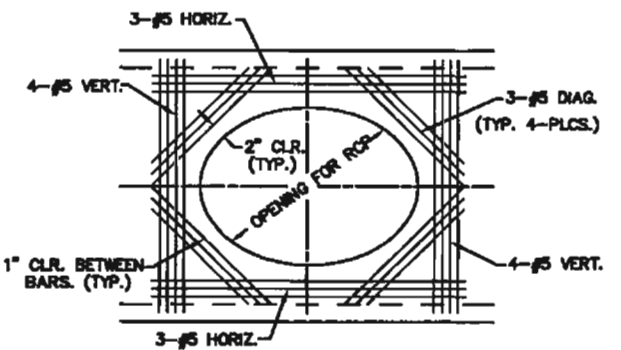

PIPE AND DROP INLET JUNCTION WALL DETAIL

NOTES:

1. ALL REBAR SHALL HAVE 2-1/2" COVER U.O.N.
2. ALL CONCRETE SHALL BE CLASS DA 4000 PSL
3. SEE PLANS FOR LENGTH (L) AND DEPTH (D) OF EACH INLET.
4. SEE PLANS FOR SIZE AND LOCATION OF OUTLET PIPE.
5. ALL EXPOSED STEEL SHALL BE HOT DIPPED GALVANIZED.
6. ALL DAMAGED GALVANIZED STEEL SHALL BE PAINTED WITH A MINIMUM 3.5 MIL COAT OF ONE OF THE FOLLOWING ZINC RICH PAINTS:
GALVONOX TYPE I
LPS GOLD GALVANIZE
SHERWIN-WILLIAMS "ZINC CLAD 1"
7. ALL REBAR SHALL BE GRADE 60.
8. ALL STRUCTURAL STEEL SHALL BE A36.
9. ALL ANCHOR BOLTS SHALL BE A-307.
10. BEDDING FOR DROP INLET SHALL BE 6" MIN. OF TYPE I AGGREGATE BASE COMPACTED TO 98% MAXIMUM DENSITY PER ASTM D1557.

H (MAX)	SLAB		WALLS	
	DIM. "S"	DIM. "W"	(A) BARS	(B) BARS
4'-0"	8"	8"	#4 @ 10" O.C.	#5 @ 12" O.C.
6'-0"	8"	8"	#5 @ 12" O.C.	#5 @ 12" O.C.
8'-0"	8"	8"	#5 @ 12" O.C.	#5 @ 12" O.C.
10'-0"	8"	8"	#5 @ 12" O.C.	#5 @ 12" O.C.

UNIFORM STANDARD DRAWINGS
CLARK COUNTY AREA

MODIFIED TYPE "A"
DROP INLET

SPECIFICATION REFERENCE

501	CONCRETE
502	CONCRETE STRUCTURES
506	REINFORCING STEEL
713	STEEL