

**UNIFORM STANDARD DRAWINGS  
CLARK COUNTY AREA**

**VOLUME I - YEAR 2001 REVISIONS**

<b><u>DRAWING NUMBER AND TITLE</u></b>	<b><u>PAGE NUMBER(S)</u></b>	<b><u>NATURE OF CHANGE</u></b>	<b><u>EFFECTIVE DATE</u></b>
200 Pavement Structure Design Guideline Chart for Major Collector and Arterial Roadways	6.1	New Drawing. Design guidelines for street structural sections which correspond to changes to Section 401 of the Standard Specifications.	1/1/01
200A Pavement Structure Design Guideline Chart for Minor Collector and Residential Roadways	6.1A	New Drawing. Design guidelines for street structural sections which correspond to changes to Section 401 of the Standard Specifications.	"
209A Access Roads	15A	New Drawing used only for access roads within PM-10 compliant areas.	"
210 Private Street Sections	16	Revision to allow gravel street sections within PM-10 compliant areas only.	"
214-216, 218-221, 223, 224, 226, 226.1, 226.2, 227, 228, 234, 234.1, 235, 237-240, 242, 252, 253, 401, 408, 411, 413, 414, 416, 505, 512-514, 516, 517	Various	Revisions to eliminate reference to specific class of concrete.	"
502 Trench Backfill-Unpaved Areas and Areas Outside Existing or Future Proposed Right-of-way	122	Revision to change requirement for the use of crushed rock as a pipe bedding material, change references for "flowable fill" to "controlled low strength material (CLSM)" and add Type III aggregate as back fill material.	6/1/01
503 Trench Backfill-Paved Areas (Streets with 60' or Less R/W)	123	Same as 502; also clarification of the mechanical placement of asphalt.	"
504 Trench Backfill with Flowable Backfill Paved Areas (Streets Greater Than 60' R/W)	124	Same as 503.	"

<b><u>DRAWING NUMBER AND TITLE</u></b>	<b><u>PAGE NUMBER(S)</u></b>	<b><u>NATURE OF CHANGE</u></b>	<b><u>EFFECTIVE DATE</u></b>
505 Pipe Trench Bedding Methods	125	Revision to change the requirement for the use of crushed rock as a pipe bedding material.	6/1/01
254A Crosswalk Markings (Except City of Las Vegas)	59.1A	Deletion of the traverse markings from the current "ladder" type marking used.	7/1/01

Revised January 2002

**FOREWORD**

**UNIFORM STANDARD DRAWINGS FOR PUBLIC WORKS' CONSTRUCTION,  
OFFSITE IMPROVEMENTS, CLARK COUNTY AREA, NEVADA  
VOLUME I**

The following participating entities of the Clark County, Nevada area have adopted these standard drawings.

CITY OF LAS VEGAS	
Adopted by City Council action . . . . .	November 4, 1987
CITY OF HENDERSON	
Adopted by City Council action . . . . .	October 20, 1987
CITY OF NORTH LAS VEGAS	
Adopted by City Council action . . . . .	November 4, 1987
CITY OF BOULDER CITY	
Adopted by City Council action . . . . .	January 26, 1988
CITY OF MESQUITE	
Adopted by City Council action . . . . .	January 26, 1988
CLARK COUNTY	
Adopted by Board action . . . . .	April 1998
REGIONAL STREET AND HIGHWAY COMMISSION	
Adopted by Commission Action . . . . .	October 8, 1987

The Uniform Standard Drawings for Public Works Construction may be revised by issuance of revisions or supplements to correct errors and omissions found in these drawings and to reflect advanced thinking and the changing technology of the construction industry. Each revision will supersede any previous pertinent drawing. Upon approval by the Regional Transportation Commission, revisions will be posted to the RTC website, [www.rtc.co.clark.nv.us](http://www.rtc.co.clark.nv.us), on the first day of the month following the meeting. **This volume contains all revisions through December 2001.**

To implement this end a Specifications Committee has been established as a permanent organization to continually study and recommend changes to the standard drawings. Interested parties may address suggested changes and questions to the Regional Transportation Commission, 600 South Grand Central Parkway, Suite 350, Las Vegas, Nevada, 89106-4512.

**UNIFORM STANDARD DRAWINGS, CLARK COUNTY AREA**

**TABLE OF CONTENTS**

**VOLUME I**

**SECTION 100**

**SYMBOLS AND ABBREVIATIONS**

<b><u>DRAWING NUMBER</u></b>		<b><u>PAGE NUMBER</u></b>
101-104	Symbols	1-4
105-106	Abbreviations	5-6

**SECTION 200**

**STREET IMPROVEMENTS**

<b>200</b>	<b><i>Pavement Structure Design Guideline Chart For Major Collector and Arterial Roadways</i></b>	<b>6.1</b>
<b>200A</b>	<b><i>Pavement Structure Design Guideline Chart For Minor Collector and Arterial Roadways</i></b>	<b>6.1A</b>
201	Minimum Back of Curb Radius	7
201.1	Additional Right-of-way Required at Major Intersections	7.1
201.2	Sight Visibility Zones at Intersections	7.2-7.2A
202	Arterial Urban Area Street Sections (City of Henderson, City of Boulder City and City of Mesquite)	8
202.1	Arterial Urban Area Street Sections (Clark County Only)	8.1
203	Arterial Urban Area Street Sections (Cities of Las Vegas and North Las Vegas)	9
204	Collector Urban Area Street Sections (City of Henderson, City of Boulder City and City of Mesquite)	10
205	Collector Urban Area Street Sections (Clark County, Las Vegas and North Las Vegas)	11
206	Local Residential Urban Area Streets Sections (City of Henderson, City of Boulder City and City of Mesquite)	12
207	Local Residential Urban Area Street Sections (Clark County, Las Vegas and North Las Vegas)	13
208	Half Street Construction Sections	14
208.1	Half Street Construction Sections (Clark County Only)	14.1
209	Access Roads (For use in Hydrographic Basin No. 212) (PM-10 Non-Attainment Areas)	15
<b>209A</b>	<b><i>Access Roads (For use in PM-10 Compliant Areas)</i></b>	<b>15A</b>
<b>210</b>	<b><i>Private Street Sections</i></b>	<b>16</b>

**SECTION 200**  
**STREET IMPROVEMENTS**  
**CONTINUED**

<b><u>DRAWING NUMBER</u></b>		<b><u>PAGE NUMBER</u></b>
211	Knuckle	17
211.1	Knuckle - Type 1 (Clark County Only)	17.1
212	Cul-De-Sac	18
213	Hammerhead (Clark County and City of Mesquite Only)	19
<b>214</b>	<b><i>Alley (Except Clark County)</i></b>	<b>20</b>
<b>215</b>	<b><i>Alley, Concrete (Except Clark County)</i></b>	<b>21</b>
<b>216</b>	<b><i>"L" Type Curb and Gutter</i></b>	<b>22</b>
217	<b>DELETED</b>	23
217A	30" Roll Curb Residential Area (Clark County, Las Vegas and North Las Vegas)	23A
<b>218</b>	<b><i>Median Island Typical Section</i></b>	<b>24</b>
<b>219</b>	<b><i>"A" and "L" Type Island Curb</i></b>	<b>25</b>
<b>220</b>	<b><i>Tack on Island Curb</i></b>	<b>26</b>
<b>221</b>	<b><i>Tack on Island (Except City of Henderson)</i></b>	<b>27</b>
222	Residential Driveway Geometrics	28
222A	Commercial and Multi-Family Driveway Geometrics	28A
<b>223</b>	<b><i>Residential Driveway</i></b>	<b>29</b>
<b>224</b>	<b><i>Commercial and Industrial Driveway (Option A)</i></b>	<b>30</b>
225	Commercial and Industrial Driveway (Option B) or Private Street Access	31
<b>226</b>	<b><i>Commercial and Industrial Driveway (Option B) (North Las Vegas)</i></b>	<b>32</b>
<b>226.1</b>	<b><i>Light-Duty Commercial Driveway (City of Henderson Only)</i></b>	<b>32.1</b>
<b>226.2</b>	<b><i>Heavy-Duty Commercial Driveway (City of Henderson Only)</i></b>	<b>32.2</b>
<b>227</b>	<b><i>Depressed Alley Driveway (City of Las Vegas)</i></b>	<b>33</b>
<b>228</b>	<b><i>Cross Gutter</i></b>	<b>34</b>
229	Half Street Cross Gutter	35
230	Concrete Pavement Intersection Typical Layout	36
231	Concrete Pavement Typical Roadway Section	37
232	Concrete Pavement Construction Details	38
233	Concrete Pavement Joint Details	39
<b>234</b>	<b><i>Sidewalk</i></b>	<b>40</b>
<b>234.1</b>	<b><i>Typical Bus Turnout</i></b>	<b>40.1</b>
234.2	Bus Stop Loading Pad and Optional Sidewalk Ramp	40.2
234.3	Bus Stop Placement within Exclusive Right Turn Lane for Commercial Properties	40.3
<b>235</b>	<b><i>Sidewalk Ramp</i></b>	<b>41-41C</b>
235.1	Sidewalk Ramp Location - "T" Intersections	41.1
236	Sidewalk Drain	42

**SECTION 200**  
**STREET IMPROVEMENTS**  
**CONTINUED**

<b><u>DRAWING NUMBER</u></b>		<b><u>PAGE NUMBER</u></b>
237	<i>Concrete Barrier Rail</i>	43
238	<i>Precast Bumper Block</i>	44
239	<i>Type I Monument</i>	45
240	<i>Type II Monument</i>	46
241	Type III Monument	47
242	<i>Type IV Monument</i>	48
243	Typical Monument Location	49
244	Typical Centerline Delineation	50
244A	Typical Lane Line Delineation	50A
244.1	Typical Delineation for Bike Facilities 100 Ft. or Greater Right-of-way	50.1
244.1A	Typical Delineation for Bike Facilities 100 Ft. Right-of-way	50.1A
244.2	Typical Delineation for Bike Facilities 80 Ft. Right-of-way	50.2
244.2A	Typical Delineation for Bike Facilities 80 Ft. Right-of-way	50.2A
244.3	Typical Delineation for Bike Facilities 60 Ft. Right-of-way (Parking on Both Sides)	50.3
245	Typical Lane Delineation in Transition Sections	51
	Details for Typical Lane Delineation in Transition Sections	51A
	Typical Lane Delineation in Transition Sections Where Traffic Flow in Same Direction	51B
245.1	Typical Lane Configuration for Major Street Intersections and Median Detail	51.1-51.1A
246	Standard Pavement Markers-Added Turn Lane	52
246A	Standard Pavement Markers - Forced Turn Lane	52A
246.1	Bike Lane Signing & Striping Intersection with Exclusive Right-Turn Lane	52.1
246.2	Pavement Marking and Signage for Right Turn At Minor Intersections	52.2
247	Marker Details and Lane Marker Schedule	53
248	Median Nose Markings	54
249	Standard Street Name Sign Post Installation	55
250 (SH1)	Street Name Signs Face Copy	56
250 (SH2)	Street Name Signs Letter Spacing	56A
251	Street Name Sign Blanks	57
252	<i>Chain Link Fence (72" High or Less)</i>	58
253	<i>Chain Link Gates</i>	59
254	Crosswalk Markings (Except Clark County)	59.1
254A	<i>Crosswalk Markings (Except City of Las Vegas)</i>	59.1A

**SECTION 300**  
**STREET LIGHTING**  
**CONTINUED**

<b><u>DRAWING NUMBER</u></b>		<b><u>PAGE NUMBER</u></b>
300	Streetlight Locations General Notes	60
301	Streetlight Locations at Intersections - 100' or Greater/100' or Greater Right-of-Way (Except Clark County)	61
301.1	Streetlight Locations at Intersections - 100' or Greater/100' or Greater Right-of-Way (Clark County Only)	61.1
302	Streetlight Locations at Intersections - 100' or Greater/80' Right-of-Way (Except Clark County)	62
302.1	Streetlight Locations at Intersections - 100' or Greater/80' Right-of-Way (Clark County Only)	62.1
303	Streetlight Locations at Intersections - 100' or Greater/60' Right-of-Way (Except Clark County)	63
303.1	Streetlight Locations at Intersections - 100' or Greater/60' Right-of-Way (Clark County Only)	63.1
304	Streetlight Locations at Intersections - 100' or Greater/51' or Less Right-of-Way (Except Clark County)	64
304.1	Streetlight Locations at Intersections - 100' or Greater/51' or Less Right-of-Way (Clark County Only)	64.1
305	Streetlight Locations at Intersections - 80'/80' Right-of-Way (Except Clark County)	65
305.1	Streetlight Locations at Intersections - 80'/80' Right-of-Way (Clark County Only)	65.1
306	Streetlight Locations at Intersections - 80'/60' Right-of-Way (Except Clark County)	66
306.1	Streetlight Locations at Intersections - 80'/60' Right-of-Way (Clark County Only)	66.1
307	Streetlight Locations at Intersections - 80'/51' or Less Right-of-Way (Except Clark County)	67
307.1	Streetlight Locations at Intersections - 80'/51' or Less Right-of-Way (Clark County Only)	67.1
308	Streetlight Locations at Intersections - 60'/60' Right-of-Way (Except Clark County)	68
308.1	Streetlight Locations at Intersections - 60'/60' Right-of-Way (Clark County Only)	68.1

**SECTION 300**  
**STREET LIGHTING**  
**CONTINUED**

<b><u>DRAWING NUMBER</u></b>		<b><u>PAGE NUMBER</u></b>
309	Streetlight Locations at Intersections - 60'/51' or Less Right-of-Way (Except Clark County)	69
309.1	Streetlight Locations at Intersections - 60'/51' or Less Right-of-Way (Clark County Only)	69.1
310	Streetlight Locations at Intersections - 51' or Less/51' or Less Right-of-Way	70
311	Streetlight Standards Maximum Spacing (80 Ft. or Greater Right-of-Way) (Except Clark County)	71
311.1	Streetlight Standards Maximum Spacing (80 Ft. or Greater Right-of-Way) (Clark County Only)	71.1
311A	Streetlight Standards Maximum Spacing (60 Ft. or Less Right-of-Way) (Except Clark County)	71A
311.1A	Streetlight Standards Maximum Spacing (60 Ft. or Less Right-of-Way) (Clark County Only)	71.1A
312	Streetlight Locations on Traffic Islands - 100' or Greater Right-of-Way	72
313	Streetlight Standard General Notes	73
314	Streetlight Standard with 2" Pipe Arm	74
315	Streetlight Standard with Double 2" Pipe Arm	75
316	Streetlight Standard with Tapered Mast Arm	76
317	Streetlight Standard with Double Tapered Mast Arm	77
318	Pole Top and Arm Mounting Details	78
319	Lower Pole Details for Pipe and Mast Arm Poles	79
320	Lighting Standard Setback	80
320A	Lighting Standard Setback from Block Wall	80A
321	Lighting Standard Foundation	81
322	Base Adaptor Plate for 1.6-1/2" Bolt Circle Foundation	82
322A	Base Adaptor Plate for 19" Bolt Circle Foundation	82A
323	Pull Box Cover Bonding Detail	83
324	Bypass Switch Bracket for Pole Mounted Streetlighting Service (City of Mesquite Only)	84
325	Modified Existing Streetlight Foundation for Installation of Underground Conduit (City of Las Vegas and Clark County Only)	85
326	Precast Reinforced Concrete Pull Box	86

**SECTION 300**  
**STREET LIGHTING**  
**CONTINUED**

<b><u>DRAWING NUMBER</u></b>		<b><u>PAGE NUMBER</u></b>
327	Pull Box Street Cover	87
328	Utility Pull Box Locations - Sidewalk and Between Driveways	88
329	Concrete Around Pull Boxes in Undeveloped Areas	89
330	Single Meter Service Pedestal	90
331	Service Pedestal Setback	91
332	Service Pedestal Foundation (Except Clark County and City of Las Vegas)	92
332.1	Service Pedestal Foundation (Clark County and City of Las Vegas)	92.1
333	Streetlighting Service Point Located on Streetlight Standard (City of Mesquite Only)	93
334	Temporary Application 120/240 VAC Service on Wood Pole - Overhead Service	94
335	Streetlight Circuit One Line Diagram (Except Clark County and City of Las Vegas)	95
335.1	Streetlight Circuit One Line Diagram (Clark County and City of Las Vegas)	95.1
336	System Grounding Plan with Pedestal Service	96
337	System Grounding Plan with Pole Mounted Service	97
338	Lighting Standard Wiring Diagram, 240 Volt, 2 Wire	98
339	Twin Lighting Standard Wiring Diagram, 240 Volt, 2 Wire	99
340	Lighting Standard Wiring Diagram, 120 Volt, 1 Phase, 3 Wire	100

**SECTION 400**  
**DRAINAGE IMPROVEMENTS**

<b>401-402</b>	<b><i>Storm Drain Manholes General Notes</i></b>	<b>101-102</b>
403	Type I Manhole	103
404	Type IA Manhole	104
405	Type II Manhole	105
406	Type III Manhole	106
407	Precast Manhole Tees	107
<b>408</b>	<b><i>Concrete Collar Around Manholes</i></b>	<b>108</b>
409	Standard Manhole Cover and Ring	109
410	Standard Manhole Steps	110
<b>411</b>	<b><i>Drop Inlet Type "A"</i></b>	<b>111</b>
412	Drop Inlet Type "B"	112
<b>413</b>	<b><i>Drop Inlet Type "C"</i></b>	<b>113</b>
<b>414</b>	<b><i>Drop Inlet Type "D"</i></b>	<b>114</b>

**SECTION 400**  
**DRAINAGE IMPROVEMENTS**  
**CONTINUED**

<b><u>DRAWING NUMBER</u></b>		<b><u>PAGE NUMBER</u></b>
415	Drop Inlet Types "A" and "B" Special Design	115
<b>416</b>	<b><i>Beehive Drop Inlet</i></b>	<b>116</b>
417	Drop Inlet Frame and Grate	117
418	Drop Inlet Steel Plate Anchorage	118
419	Drop Inlet Steel Plate and Protection Bar	119
420	Typical Open Channel	120

**SECTION 500**  
**UTILITIES AND MISCELLANEOUS IMPROVEMENTS**

501	Typical Underground Utility Locations in Street	121
<b>502</b>	<b><i>Trench Backfill Unpaved Areas and Areas Outside Existing or Future Proposed Street Right-of-way</i></b>	<b>122</b>
<b>503</b>	<b><i>Trench Backfill Paved Areas (Streets with 60' or Less R/W)</i></b>	<b>123</b>
<b>504</b>	<b><i>Trench Backfill With Controlled Low Strength Material (CLSM) Paved Areas (Streets Greater than 60' R/W)</i></b>	<b>124</b>
<b>505</b>	<b><i>Pipe Trench Bedding Methods</i></b>	<b>125</b>
506	Service Installation, 5/8", 3/4", and 1" Meter Sizes-Improved Area	126
507	Service Installation, 5/8", 3/4", and 1" Meter Sizes-Unimproved Area	127
508	Service Installation, Dual 5/8", 3/4", and 1" Meter Sizes-Improved Area	128
509	Service Installation, Dual 5/8", 3/4", and 1" Meter Sizes-Unimproved Area	129
510	Service Installation, 1-1/2" and 2" Meter Sizes-Improved Area	130
511	Service Installation, 1-1/2" and 2" Meter Sizes-Unimproved Area	131
<b>512</b>	<b><i>Thrust Block Details</i></b>	<b>132</b>
<b>513</b>	<b><i>Anchor Block Details Reducer or Valve</i></b>	<b>133</b>
<b>514</b>	<b><i>Blow - Off Assembly Locations</i></b>	<b>134</b>
515	Blow - Off Assembly 4", 6", 8", and 10" Mains	135
<b>516</b>	<b><i>Fire Hydrant Installation</i></b>	<b>136</b>
<b>517</b>	<b><i>Valve Box Installation and Adjustment</i></b>	<b>137</b>
518	Chlorination Requirements	138
	No Drawing Assigned	139

**SECTION 600**  
**TRAFFIC CONTROL PLANS FOR HIGHWAY WORK ZONE**  
**CONTINUED**

<b><u>DRAWING NUMBER</u></b>		<b><u>PAGE NUMBER</u></b>
601	Barricades & Flagger Traffic Control Sign Standard Designs (2 Sheets)	140-140A
602	Portable Concrete Barrier Rail (2 Sheets)	141-141A
603	Short Time, Day or Night Operations	142
604	Rural Moving Day Operations Where Activities Encroach on the Shoulder	143
605	Rural Moving Day Operations Where Activities Encroach on the Pavement	144
606	2-Lane, 2-Way Rural Day or Night Operations Where Activities Are More Than 15 Ft. from Edge of Pavement	145
607	2-Lane, 2-Way Rural Day or Night Operations Where Activities Will Encroach Between 15 Ft. & 2 Ft. Outside of Pavement Edge	146
608	2-Lane, 2-Way Rural Day Operations Where Activities Will Encroach Between Centerline And 2 Ft. Outside of Pavement Edge	147
609	2-Lane, 2-Way Rural Night Operations Where Activities Will Encroach Between Centerline & 2 Ft. Outside of Pavement Edge	148
610	2-Lane, 2-Way Rural Day or Night Operations Where Activities Will Encroach Between Centerline & 2 Ft. Outside of Pavement Edge	149
611	2-Lane, 2-Way, Rural or Suburban, Day or Night Pavement Widening	150
612 (SH1)	2-Lane, 2-Way, Rural or Suburban, Day or Night Temporary <u>Paved</u> Bypass	151
612 (SH2)	2-Lane, 2-Way, Rural or Suburban, Day or Night Temporary <u>Unpaved</u> Bypass	151A
613	2-Lane, 2-Way Rural Day or Night Operations With One Lane Closed	152
614	Multilane, Divided or Undivided, Rural or Suburban, Day or Night Operations Where Activities Are More Than 15 Ft From Edge of Pavement	153
615	Multilane, Divided or Undivided, Rural or Suburban, Day or Night Operations Where Activities Will Encroach Between 15 Ft. & 2 Ft. Outside Pavement Edge	154
616	Multilane, Divided, Rural or Suburban, Day Operations Where Operation Moves Between 1 and 15 MPH	155

**SECTION 600**  
**TRAFFIC CONTROL PLANS FOR HIGHWAY WORK ZONE**  
**CONTINUED**

<b><u>DRAWING NUMBER</u></b>		<b><u>PAGE NUMBER</u></b>
617	Multilane, Divided or Undivided, Rural or Suburban, Day Operations Where Activities Will Encroach on Lane Abutting Shoulder or on the Shoulder within 2 Ft. Outside the Pavement Edge	156
618	Multilane, Divided or Undivided, Rural or Suburban, Day and Night Operations Where Activities Will Encroach on Lane Abutting Shoulder or on the Shoulder within 2 Ft. Outside the Pavement Edge	157
619	Multilane, Undivided, Rural or Suburban, Day/Night Operations with a Work Area in the Left Lane, Allowing Work Access from Adjacent Lane	158
620	Multilane, 1-Way or Divided, Rural or Suburban, Day/Night Operations Where Center Lane(s) Are Closed	159
621	Multilane, Divided, Rural or Suburban, Day or Night Where Activities Require Closing 2 Adjacent Lanes & an Opposing Lane is Used for a Temporary Crossover	160
622	Work Areas within or near Suburban Intersections	161
623	2-Lane, 2-Way, Rural or Suburban, Day or Night Road Closure	162
624	Controlling Pedestrian Traffic	163
625	Slow Moving or Short Duration Stopping <u>IN</u> a Marked Travel Lane on Non-Local Streets	164
626	Placement of "No Parking" Signs for Short-Term Street Rehabilitation Projects	165
627	Standard for "Speeding Penalties Doubled" Sign for Use in Temporary Traffic Control Zones	166

R-Value	RESIDENTIAL								MINOR COLLECTOR							
	Normal Traffic (5.0)				Heavy Traffic (5.5)				Normal Traffic (6.0)				Heavy Traffic (6.5)			
	SN	AC	T-II	T-I	SN	AC	T-II	T-I	SN	AC	T-II	T-I	SN	AC	T-II	T-I
16	170	2.0	4.0	5.0	200	2.5	4.0	6.0	225	3.0	4.0	6.5	250	3.5	4.0	7.5
18	170	2.0	4.0	5.0	195	2.5	4.0	5.5	220	3.0	4.0	6.0	245	3.5	4.0	7.0
20	165	2.0	4.0	4.5	190	2.5	4.0	5.0	215	3.0	4.0	5.5	240	3.5	4.0	6.5
22	160	2.0	4.0	4.0	185	2.5	4.0	4.5	205	3.0	4.0	5.0	235	3.5	4.0	6.0
24	155	2.0	7.5	NA	180	2.5	4.0	4.0	200	3.0	4.0	4.5	225	3.5	4.0	5.0
26	150	2.0	7.0	NA	175	2.5	7.5	NA	195	3.0	4.0	4.0	220	3.5	4.0	4.5
28	145	2.0	6.5	NA	170	2.5	7.0	NA	190	3.0	7.5	NA	215	3.5	4.0	4.0
30	140	2.0	6.0	NA	165	2.5	6.5	NA	185	3.0	7.0	NA	210	3.5	7.5	NA
32	135	2.0	5.5	NA	160	2.5	6.0	NA	180	3.0	6.5	NA	205	3.5	7.0	NA
34	135	2.0	5.5	NA	155	2.5	6.0	NA	175	3.0	6.0	NA	200	3.5	6.5	NA
36	130	2.0	5.0	NA	150	2.5	5.5	NA	170	3.0	5.5	NA	195	3.5	6.0	NA
38	125	2.0	5.0	NA	145	2.5	5.0	NA	165	3.0	5.0	NA	185	3.5	5.5	NA
40	120	2.0	4.5	NA	140	2.5	4.5	NA	160	3.0	5.0	NA	180	3.5	5.0	NA
42	115	2.0	4.0	NA	135	2.5	4.0	NA	155	3.0	4.5	NA	175	3.5	4.5	NA
44	115	2.0	4.0	NA	135	2.5	4.0	NA	155	3.0	4.5	NA	170	3.5	4.0	NA
46	110	2.0	4.0	NA	130	2.0	5.0	NA	150	3.0	4.0	NA	170	3.5	4.0	NA
48	105	2.0	4.0	NA	125	2.0	5.0	NA	145	3.0	4.0	NA	165	3.0	5.0	NA
50	105	2.0	4.0	NA	120	2.0	4.5	NA	140	3.0	4.0	NA	160	3.0	5.0	NA
52	100	2.0	4.0	NA	120	2.0	4.5	NA	135	3.0	4.0	NA	155	3.0	4.5	NA
54	0.95	2.0	4.0	NA	115	2.0	4.0	NA	130	3.0	4.0	NA	150	3.0	4.0	NA
56	0.95	2.0	4.0	NA	110	2.0	4.0	NA	130	3.0	4.0	NA	145	3.0	4.0	NA
58	0.90	2.0	4.0	NA	105	2.0	4.0	NA	125	3.0	4.0	NA	140	3.0	4.0	NA
60	0.85	2.0	4.0	NA	105	2.0	4.0	NA	120	3.0	4.0	NA	135	3.0	4.0	NA
62	0.85	2.0	4.0	NA	100	2.0	4.0	NA	115	3.0	4.0	NA	135	3.0	4.0	NA
64	0.80	2.0	4.0	NA	0.95	2.0	4.0	NA	115	3.0	4.0	NA	130	3.0	4.0	NA
66	0.75	2.0	4.0	NA	0.95	2.0	4.0	NA	110	3.0	4.0	NA	125	3.0	4.0	NA
68	0.75	2.0	4.0	NA	0.90	2.0	4.0	NA	105	3.0	4.0	NA	120	3.0	4.0	NA
70	0.70	2.0	4.0	NA	0.85	2.0	4.0	NA	100	3.0	4.0	NA	115	3.0	4.0	NA
72	0.70	2.0	4.0	NA	0.80	2.0	4.0	NA	100	3.0	4.0	NA	115	3.0	4.0	NA
74	0.65	2.0	4.0	NA	0.75	2.0	4.0	NA	0.95	3.0	4.0	NA	110	3.0	4.0	NA
76	0.65	2.0	4.0	NA	0.75	2.0	4.0	NA	0.90	3.0	4.0	NA	105	3.0	4.0	NA
78	0.65	2.0	4.0	NA	0.70	2.0	4.0	NA	0.85	3.0	4.0	NA	105	3.0	4.0	NA

**NOTES:**

1. THIS CHART WAS CONSTRUCTED USING THE 1993 AASHTO PAVEMENT DESIGN GUIDE, 1996 NDOT MANUAL AND THE 2000 RTC DESIGN CRITERIA, SECTION 401.01.02 OF THE STANDARD SPECIFICATIONS.
2. AN AVERAGE R-VALUE MAY BE USED IF IT IS REPRESENTATIVE OF ALL PROJECT CONDITIONS.
3. ADDITIONAL DESIGN COMPENSATION IS REQUIRED IF EXPANSIVE SOILS, HYDRO-COLLAPSIBLE SOILS, OR SOLUBLE MATERIALS ARE PRESENT.
4. AC DEPTHS SHOWN ARE MINIMUMS AND 4" MINIMUM TYPE II IS REQUIRED; OTHER COMBINATIONS THAT MEET OR EXCEED THE STRUCTURAL NUMBER REQUIREMENTS ARE ACCEPTABLE.

<b>SPECIFICATION REFERENCE</b>		<b>UNIFORM STANDARD DRAWINGS CLARK COUNTY AREA</b>			
401	PLANTMIX BITUMINOUS PAVEMENTS				
		<b>PAVEMENT STRUCTURE DESIGN GUIDELINE CHART FOR MINOR COLLECTOR AND RESIDENTIAL ROADWAYS</b>			
		DATE 12-14-00	DWG. NO.	200A	PAGE NO. 6.1A

R-Value	MAJOR COLLECTOR								ARTERIAL							
	Normal Traffic (8.0)				Heavy Traffic (8.5)				Normal Traffic (9.0)				Heavy Traffic (9.5)			
	SN	AC	T-II	T-I	SN	AC	T-II	T-I	SN	AC	T-II	T-I	SN	AC	T-II	T-I
16	3.35	4.0	4.0	13.5	3.65	4.5	4.0	14.5	4.25	5.0	4.0	18.5	4.55	5.5	4.0	19.5
18	3.30	4.0	4.0	13.0	3.55	4.5	4.0	14.0	4.15	5.0	4.0	17.5	4.45	5.5	4.0	19.0
20	3.20	4.0	4.0	12.0	3.45	4.5	4.0	13.0	4.05	5.0	4.0	16.5	4.35	5.5	4.0	18.0
22	3.10	4.0	4.0	11.5	3.40	4.5	4.0	12.5	3.95	5.0	4.0	16.0	4.25	5.5	4.0	17.0
24	3.05	4.0	4.0	11.0	3.30	4.5	4.0	11.5	3.85	5.0	4.0	15.0	4.15	5.5	4.0	16.0
26	2.95	4.0	4.0	10.0	3.20	4.5	4.0	10.5	3.75	5.0	4.0	14.0	4.05	5.5	4.0	15.0
28	2.90	4.0	4.0	9.5	3.15	4.5	4.0	10.0	3.65	5.0	4.0	13.0	3.95	5.5	4.0	14.0
30	2.80	4.0	4.0	8.5	3.05	4.5	4.0	9.0	3.55	5.0	4.0	12.00	3.85	5.5	4.0	13.5
32	2.75	4.0	4.0	8.0	2.95	4.5	4.0	8.5	3.45	5.0	4.0	11.5	3.75	5.5	4.0	12.5
34	2.65	4.0	4.0	7.0	2.90	4.5	4.0	8.0	3.40	5.0	4.0	11.0	3.65	5.5	4.0	11.5
36	2.60	4.0	4.0	6.5	2.80	4.5	4.0	7.0	3.30	5.0	4.0	10.0	3.55	5.5	4.0	10.5
38	2.50	4.0	4.0	6.0	2.75	4.5	4.0	6.5	3.20	5.0	4.0	9.0	3.45	5.5	4.0	9.5
40	2.45	4.0	4.0	5.5	2.65	4.5	4.0	5.5	3.15	5.0	4.0	8.5	3.35	5.5	4.0	9.0
42	2.40	4.0	4.0	5.0	2.60	4.5	4.0	5.0	3.05	5.0	4.0	7.5	3.30	5.5	4.0	8.5
44	2.35	4.0	4.0	4.5	2.55	4.5	4.0	4.5	2.95	5.0	4.0	7.0	3.20	5.5	4.0	7.5
46	2.25	4.0	4.0	4.0	2.45	4.5	4.0	4.0	2.90	5.0	4.0	6.5	3.10	5.5	4.0	6.5
48	2.20	4.0	7.0	NA	2.40	4.5	7.0	NA	2.80	5.0	4.0	5.5	3.05	5.5	4.0	6.0
50	2.15	4.0	6.5	NA	2.35	4.5	6.5	NA	2.75	5.0	4.0	5.0	2.95	5.5	4.0	5.0
52	2.10	4.0	6.0	NA	2.30	4.5	6.0	NA	2.65	5.0	4.0	4.0	2.90	5.5	4.0	4.5
54	2.05	4.0	5.5	NA	2.20	4.5	5.5	NA	2.60	5.0	7.5	NA	2.80	5.5	4.0	4.0
56	2.00	4.0	5.0	NA	2.15	4.5	5.0	NA	2.55	5.0	7.0	NA	2.75	5.5	7.0	NA
58	1.95	4.0	5.0	NA	2.10	4.5	4.5	NA	2.45	5.0	6.0	NA	2.65	5.5	6.5	NA
60	1.90	4.0	4.5	NA	2.05	4.5	4.0	NA	2.40	5.0	5.5	NA	2.60	5.5	6.0	NA
62	1.85	4.0	4.0	NA	2.00	4.0	5.0	NA	2.35	5.0	5.0	NA	2.50	5.5	5.0	NA
64	1.80	4.0	4.0	NA	1.95	4.0	5.0	NA	2.30	5.0	4.5	NA	2.45	5.5	4.5	NA
66	1.75	4.0	4.0	NA	1.90	4.0	4.5	NA	2.20	5.0	4.0	NA	2.40	5.5	4.0	NA
68	1.70	4.0	4.0	NA	1.85	4.0	4.0	NA	2.15	4.5	5.0	NA	2.35	5.0	5.0	NA
70	1.65	4.0	4.0	NA	1.80	4.0	4.0	NA	2.10	4.5	4.5	NA	2.25	5.0	4.5	NA
72	1.60	4.0	4.0	NA	1.75	4.0	4.0	NA	2.05	4.5	4.0	NA	2.20	5.0	4.0	NA
74	1.55	4.0	4.0	NA	1.70	4.0	4.0	NA	2.00	4.0	5.0	NA	2.15	4.5	5.0	NA
76	1.50	4.0	4.0	NA	1.65	4.0	4.0	NA	1.95	4.0	4.5	NA	2.10	4.5	4.5	NA
78	1.45	4.0	4.0	NA	1.60	4.0	4.0	NA	1.90	4.0	4.0	NA	2.05	4.5	4.0	NA

**NOTES:**

1. THIS CHART WAS CONSTRUCTED USING THE 1993 AASHTO PAVEMENT DESIGN GUIDE, 1996 NDOT MANUAL AND THE 2000 RTC DESIGN CRITERIA, SECTION 40101.02 OF THE STANDARD SPECIFICATIONS.
2. A TRAFFIC STUDY MAY BE REQUIRED IF  $TI > 9.5$ .
3. AN AVERAGE R-VALUE MAY BE USED IF IT IS REPRESENTATIVE OF ALL PROJECT CONDITIONS.
4. ADDITIONAL DESIGN COMPENSATION IS REQUIRED IF EXPANSIVE SOILS, HYDRO-COLLAPSIBLE SOILS, OR SOLUBLE MATERIALS ARE PRESENT.
5. AC DEPTHS SHOWN ARE MINIMUMS AND 4" MINIMUM TYPE II IS REQUIRED; OTHER COMBINATIONS THAT MEET OR EXCEED THE STRUCTURAL NUMBER REQUIREMENTS ARE ACCEPTABLE.

SPECIFICATION REFERENCE		UNIFORM STANDARD DRAWINGS CLARK COUNTY AREA			
401	PLANTMIX BITUMINOUS PAVEMENTS	PAVEMENT STRUCTURE DESIGN GUIDELINE CHART FOR MAJOR COLLECTOR AND ARTERIAL ROADWAYS			
		DATE 12-14-00	DWG. NO.	200	PAGE NO. 61

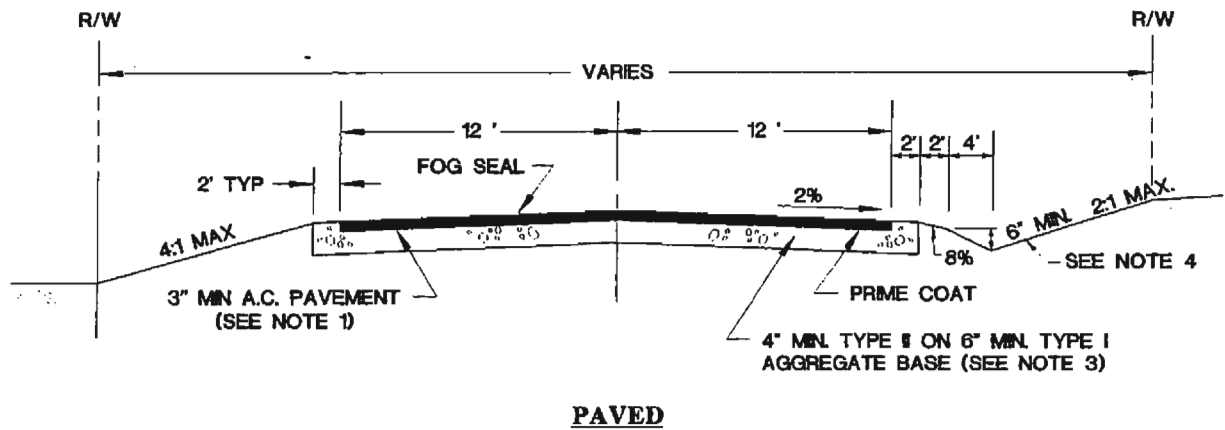
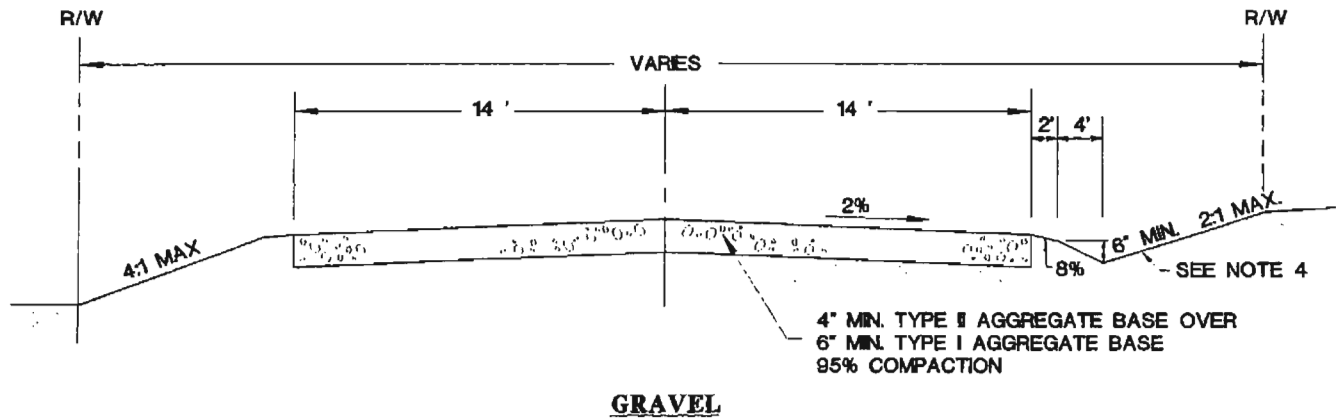

**NOTES:**

1. INTERSECTIONS SHALL HAVE 25 FOOT MINIMUM EDGE OF OIL RADII.
2. COMPACTION OF AGGREGATE BASE AND SUBGRADE PREPARATION SHALL BE IN ACCORDANCE WITH THE "STANDARD SPECIFICATIONS".
3. STRUCTURAL SECTION SHOWN IS BASED ON A SUBGRADE "R" VALUE OF 20. OTHER STRUCTURAL SECTIONS MAY BE APPROVED IF BASED ON ENGINEERING ANALYSIS BASED ON "R" OR "CBR" VALUES DETERMINED BY SOIL TESTING. IN NO CASE SHALL THE A.C. THICKNESS BE LESS THAN THAT SHOWN, NOR SHALL THE BASE BE LESS THAN 4".
4. CULVERTS MAY BE REQUIRED AT DRIVEWAYS.

SPECIFICATION REFERENCE		UNIFORM STANDARD DRAWINGS CLARK COUNTY AREA		
302	AGGREGATE BASE	<b>ACCESS ROADS</b> (FOR USE IN PM-10 COMPLIANT AREAS)		
401	BITUMINOUS PAVEMENT			
406	PRIME COAT			
407	FOG SEAL			
		DATE 12-14-00	DWG. NO. 209A	PAGE NO. 15A

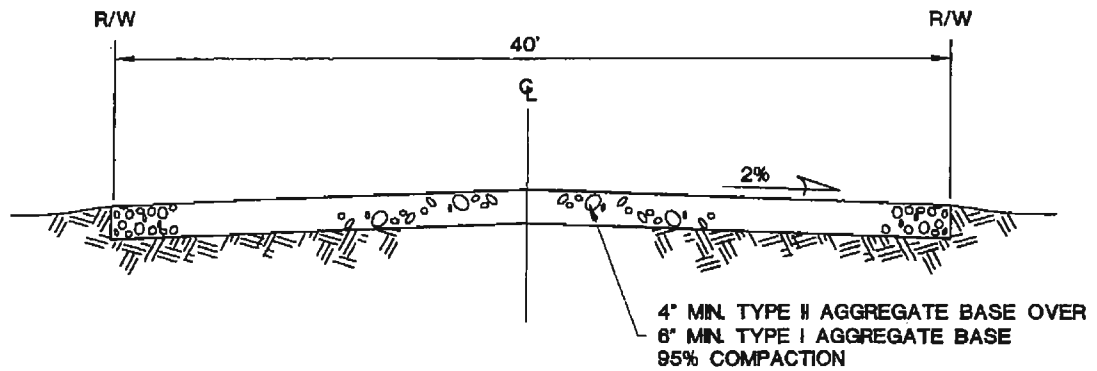

**GRAVEL**

(THIS SECTION NOT FOR USE IN PM-10 NON-ATTAINMENT AREAS)

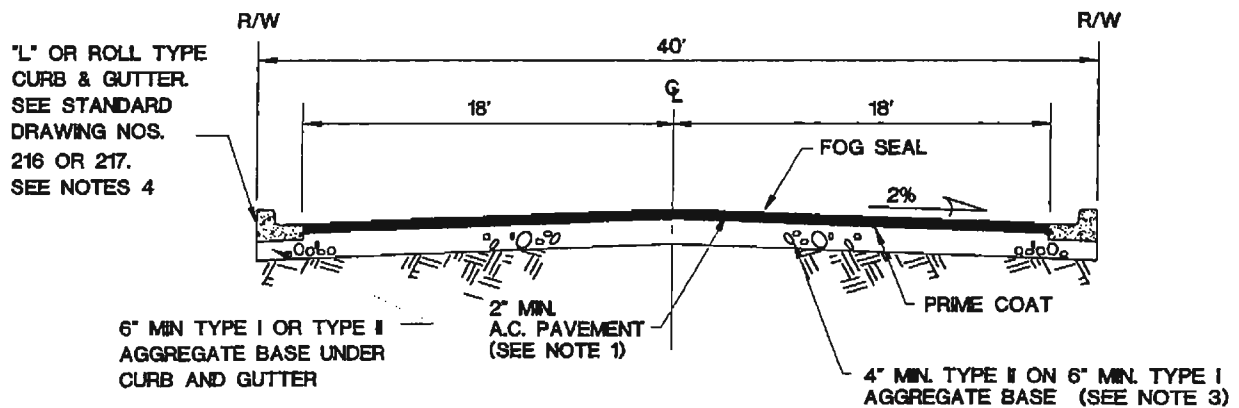

**PAVED**

**NOTES:**

1. INTERSECTIONS SHALL HAVE 25 FOOT MINIMUM EDGE OF OIL RADI<sup>1</sup> OR 20 FOOT MINIMUM BACK OF CURB RADII.
2. COMPACTION OF AGGREGATE BASE AND SUBGRADE PREPARATION SHALL BE IN ACCORDANCE WITH THE "STANDARD SPECIFICATION".
3. STRUCTURAL SECTION SHOWN IS BASED ON A SUBGRADE "R" VALUE OF 20. OTHER STRUCTURAL SECTIONS MAY BE APPROVED IF BASED ON ENGINEERING ANALYSIS BASED ON "R" OR "CBR" VALUES DETERMINED BY SOIL TESTING. IN NO CASE SHALL THE A.C. THICKNESS BE LESS THAN THAT SHOWN, NOR SHALL THE BASE BE LESS THAN 4" EXCEPT THAT THE BASE SHALL NOT BE LESS THAN 10" IN NORTH LAS VEGAS.
4. ALLOW IN CITY OF NORTH LAS VEGAS ONLY WITH EXPRESS WRITTEN PERMISSION FROM THE CITY ENGINEER.

SPECIFICATION REFERENCE		UNIFORM STANDARD DRAWINGS CLARK COUNTY AREA		
302	AGGREGATE BASE	PRIVATE STREET SECTIONS		
401	BITUMINOUS PAVEMENT			
406	PRIME COAT			
407	FOG SEAL			
501	CONCRETE			
		DATE 12-14-00	DWG. NO. 210	PAGE 16

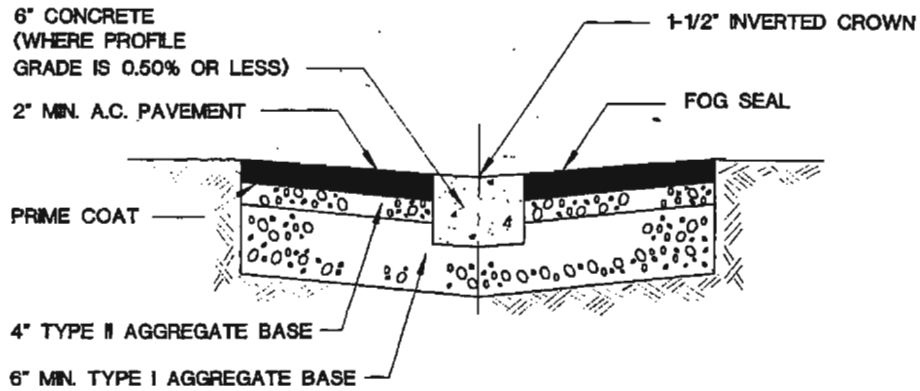

**SECTION A-A**

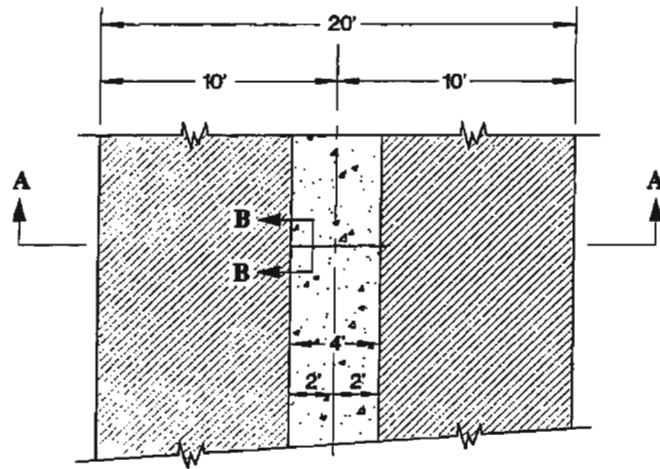

**PLAN**

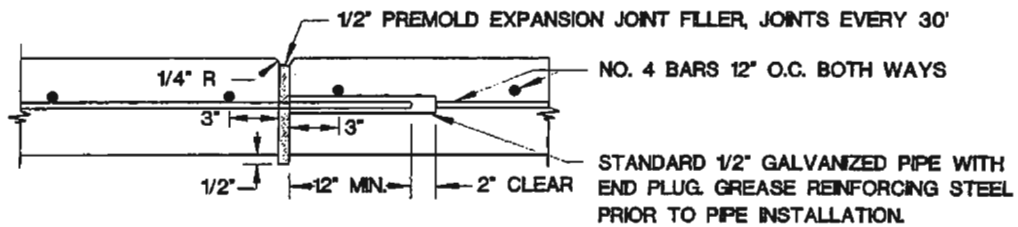

**SECTION B-B**

SPECIFICATION REFERENCE		UNIFORM STANDARD DRAWINGS CLARK COUNTY AREA		
302	AGGREGATE BASE	EXCEPT CLARK COUNTY ALLEY		
501	CONCRETE			
505	REINFORCING STEEL			
707	JOINT MATERIAL			
		DATE 12-14-00	DWG. NO. 214	PAGE NO. 20

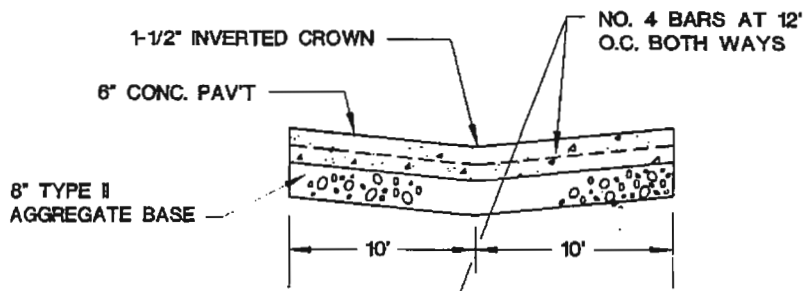

**SECTION**

NO. 4 BARS TO DISCONTINUE WITHIN 2" OF JOINT MATERIAL

WEAKENED PLANE JOINTS 1/4" MAX. WIDTH BY 2" DEPTH SAWCUT

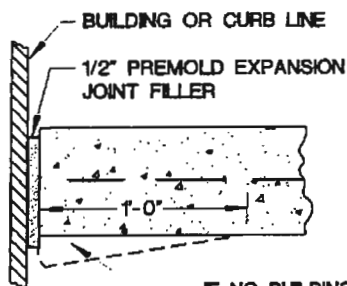

IF NO BUILDING OR CURB EXISTS THICKEN EDGE TO 8" TOTAL DEPTH

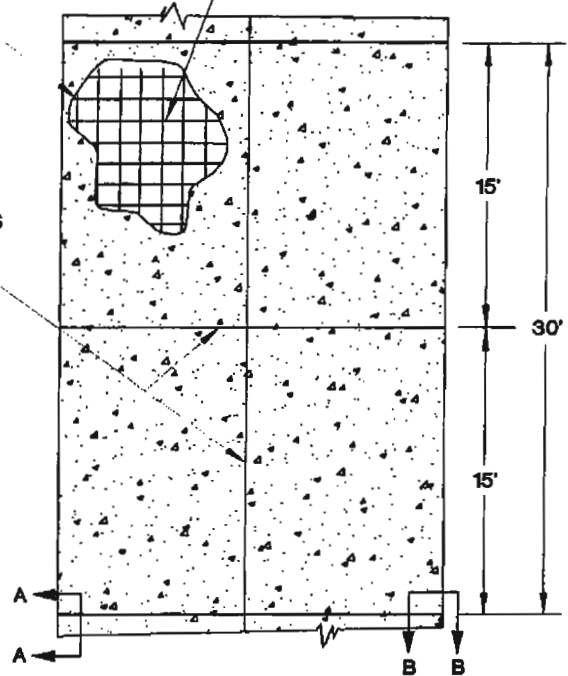

**PLAN**

**SECTION B-B**

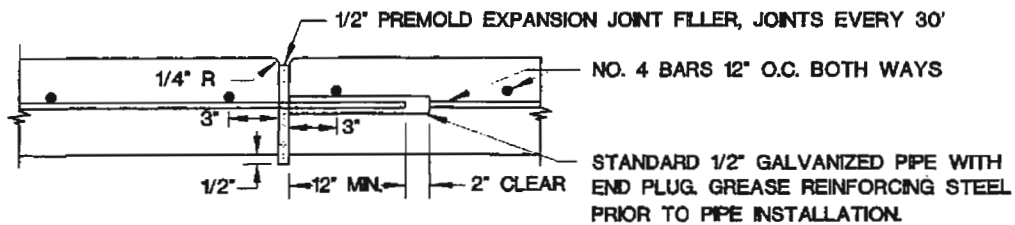

**SECTION A-A**

SPECIFICATION REFERENCE		UNIFORM STANDARD DRAWINGS CLARK COUNTY AREA	
302	AGGREGATE BASE	EXCEPT CLARK COUNTY ALLEY, CONCRETE	
501	CONCRETE		
505	REINFORCING STEEL		
707	JOINT MATERIAL		
		DATE 12-14-00	DWG. NO. 215
		PAGE NO. 21	



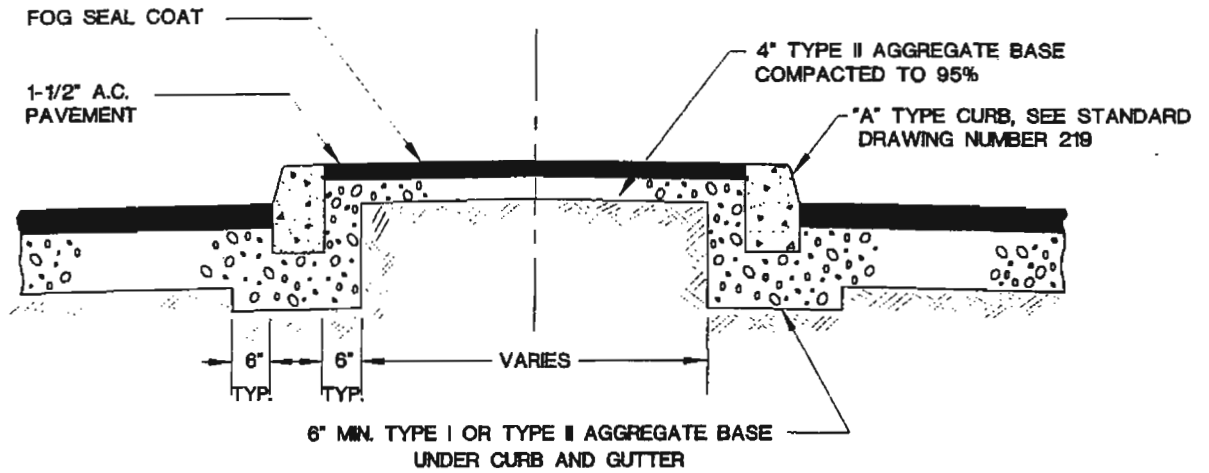

**AC MEDIAN**

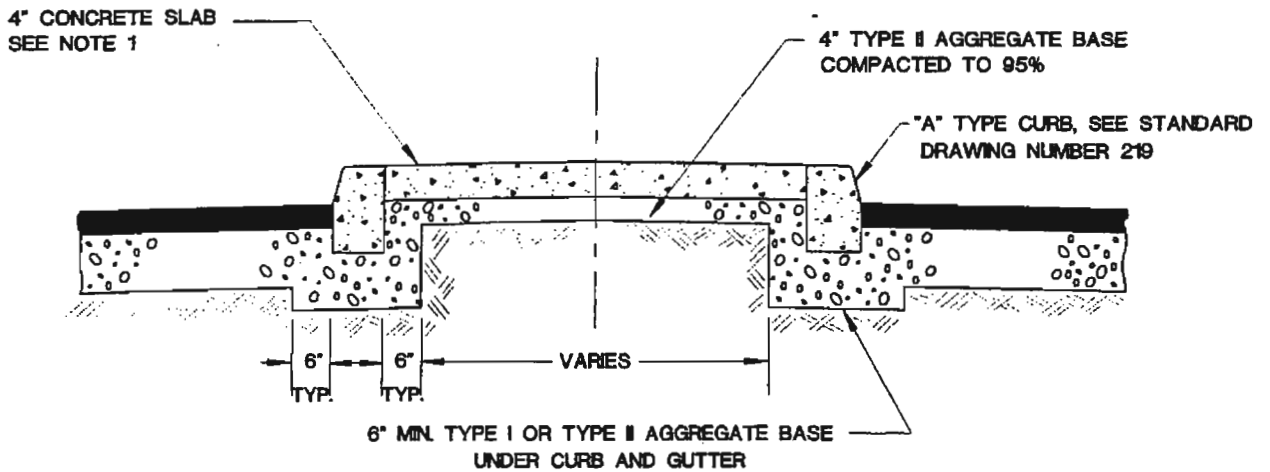

**PCC MEDIAN**

**NOTES:**

1. CONSTRUCT WEAKENED PLANE JOINT IN CURB AND SLAB AT SAME LOCATION EVERY 10'; CONSTRUCT EXPANSION JOINTS EVERY 300' FOR CONCRETE SLAB TO MATCH CURB JOINTS. FOR JOINT DETAILS SEE STANDARD DRAWING NUMBER 234.
2. "L" -TYPE CURB AND GUTTER PER STANDARD DRAWING NUMBER 221 IS REQUIRED IN THE CITY OF HENDERSON AND MAY BE REQUIRED FOR DRAINAGE CONSIDERATIONS.
3. WHEN CURB MACHINE IS USED TO PLACE CURB, A 2" MINIMUM LEVELING COURSE OF TYPE II AGGREGATE BASE IS REQUIRED.

<b>SPECIFICATION REFERENCE</b>		<b>UNIFORM STANDARD DRAWINGS CLARK COUNTY AREA</b>		
302	AGGREGATE BASE	<b>MEDIAN ISLAND TYPICAL SECTION</b>		
501	CONCRETE			
		DATE 12-14-00	DWG. NO. 218	PAGE NO. 24

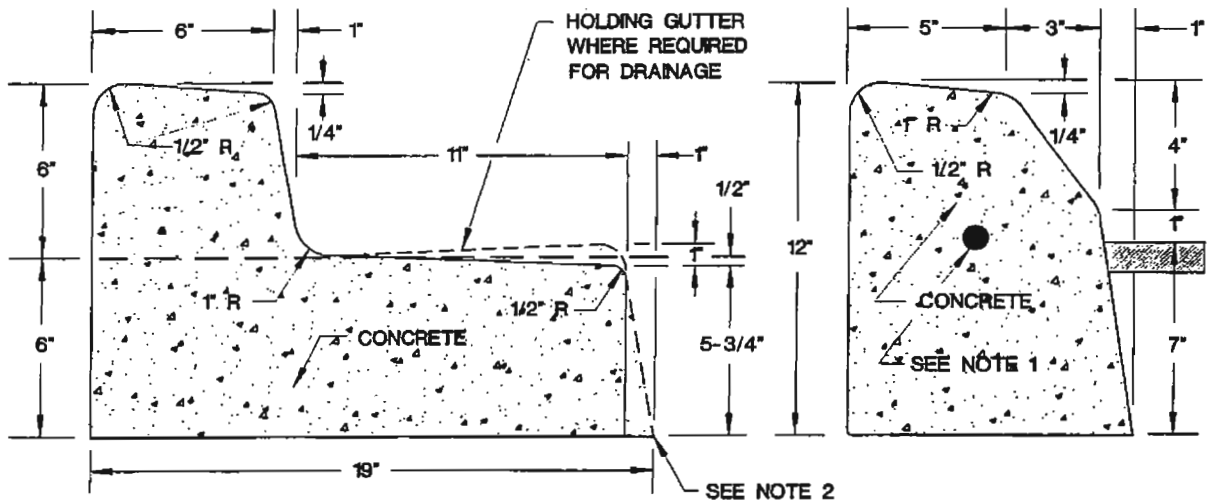

**"L" CURB SECTION**

**"A" CURB SECTION**

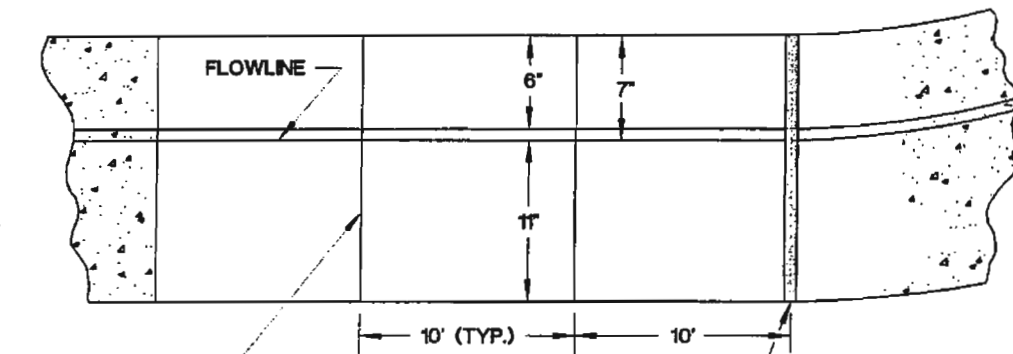

**TYPICAL PLAN**

WEAKENED  
PLANE JOINTS  
SEE STANDARD DRAWING  
NUMBER 234

1/2" EXPANSION JOINT AT  
ALL COLD JOINTS, AT  
BEGINNING AND END OF  
RETURN AND AT 300' MAX.  
INTERVALS FOR EXTRUDED  
CURB AND 30' MAX. INTERVALS  
FOR FORMED CURB. FOR JOINT  
DETAIL SEE STANDARD DRAWING  
NUMBER 234

**NOTES:**

1. CONTINUOUS NO. 4 BAR REQUIRED IN NOSE OF MEDIAN ONLY.
2. 1" BATTER ON GUTTER FACE OPTIONAL.

SPECIFICATION REFERENCE		UNIFORM STANDARD DRAWINGS CLARK COUNTY AREA		
302	AGGREGATE BASE COURSE	<b>"A" AND "L" TYPE ISLAND CURB</b>		
501	CONCRETE			
707	JOINT MATERIAL			
		DATE 12-14-00	DWG. NO. 219	PAGE NO. 25

1/2" RADIUS ROUNDED  
EDGE ON ALL EXPOSED  
CORNERS

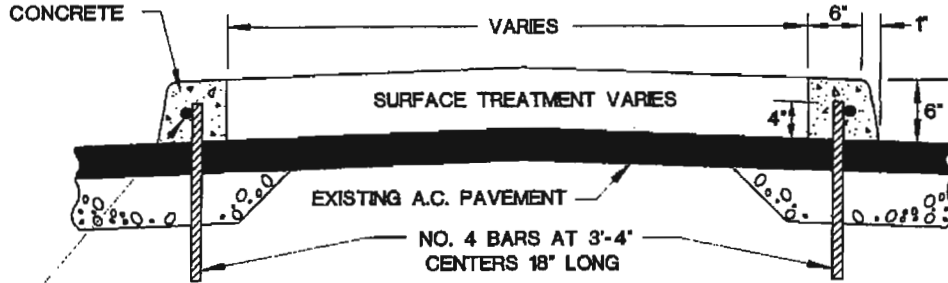

NO. 4 BAR CONTINUOUS  
EXCEPT THROUGH  
EXPANSION JOINT

**SECTION**

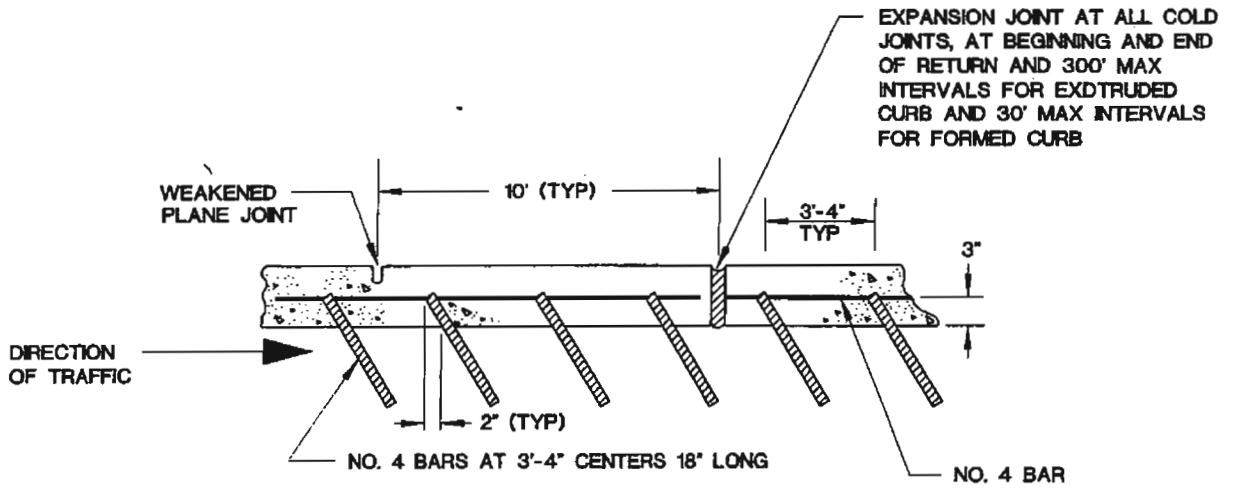

**SIDE VIEW**

**NOTES:**

1. FOR EXPANSION JOINT AND WEAKENED PLANE JOINT DETAIL, SEE STANDARD DRAWING NO. 234.
2. WEAKENED PLANE JOINTS EVERY 10' STAGGER WITH NO. 4 BARS.
3. ALL REINFORCING STEEL SHALL HAVE 2" CLEAR COVER UNLESS OTHERWISE SHOWN.

<b>SPECIFICATION REFERENCE</b>		<b>UNIFORM STANDARD DRAWINGS CLARK COUNTY AREA</b>		
501	CONCRETE	<b>TACK ON ISLAND CURB</b>		
505	REINFORCING STEEL			
707	JOINT MATERIAL			
		DATE 12-14-00	DWG. NO. 220	PAGE NO. 26

1/2" RADIUS ROUNDED  
EDGE ON ALL EXPOSED  
CORNERS

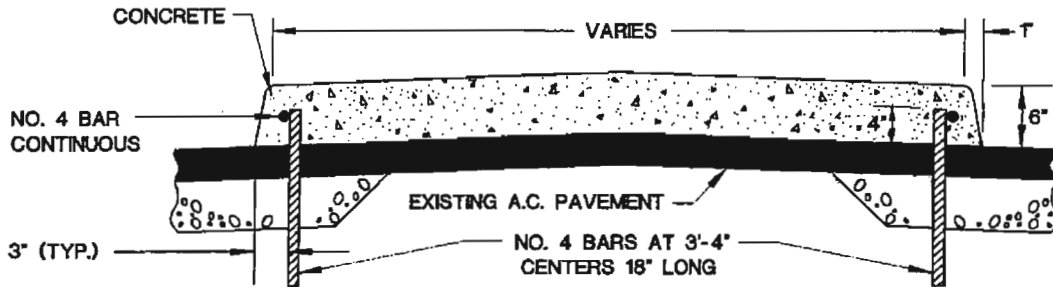

**SECTION**

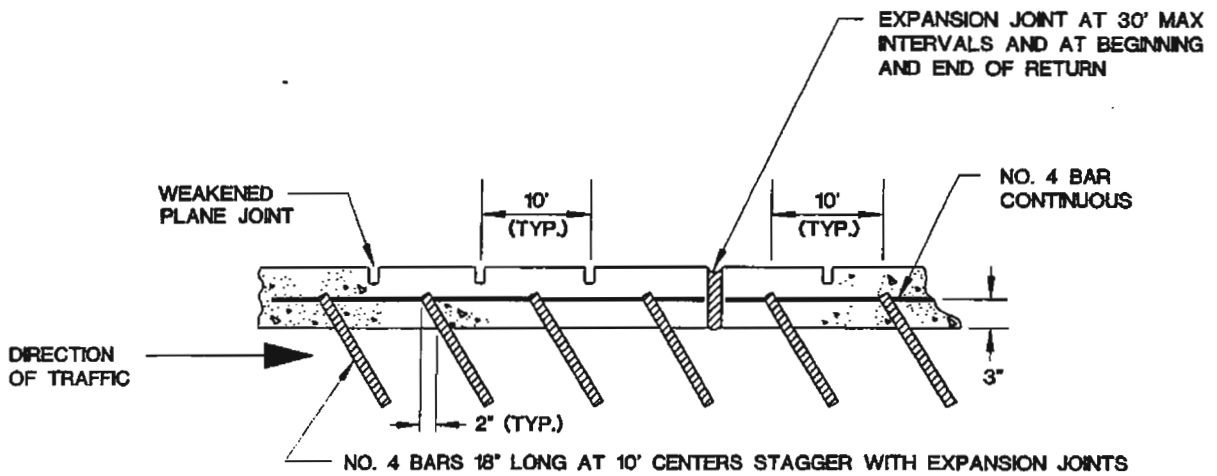

**SIDE VIEW**

**NOTES:**

1. FOR EXPANSION JOINT AND WEAKENED PLANE JOINT DETAIL, SEE STANDARD DRAWING NO. 234.

SPECIFICATION REFERENCE		UNIFORM STANDARD DRAWINGS CLARK COUNTY AREA		
501	CONCRETE	EXCEPT CITY OF HENDERSON TACK ON ISLAND		
505	REINFORCING STEEL			
707	JOINT MATERIAL			
		DATE 12-14-00	DWG. NO. 221	PAGE NO. 27

PROPERTY LINE AND/OR  
BACK OF SIDEWALK

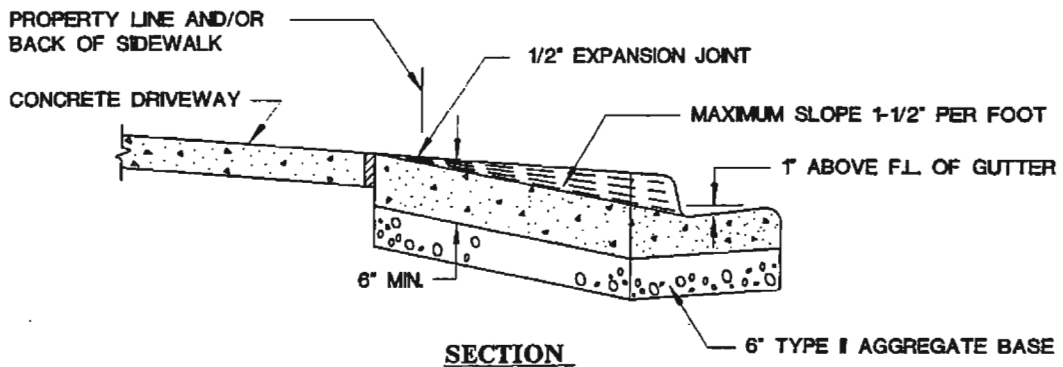
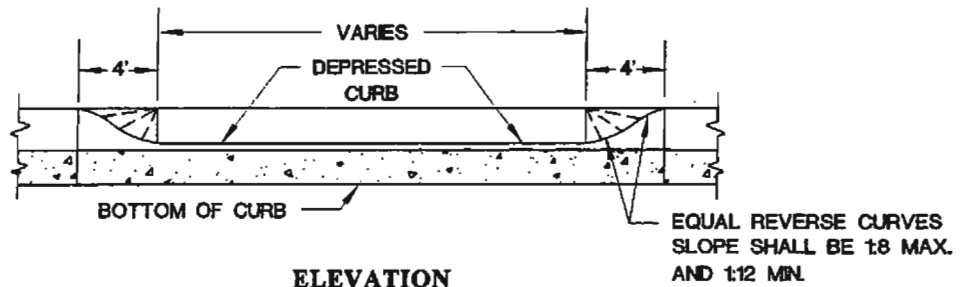
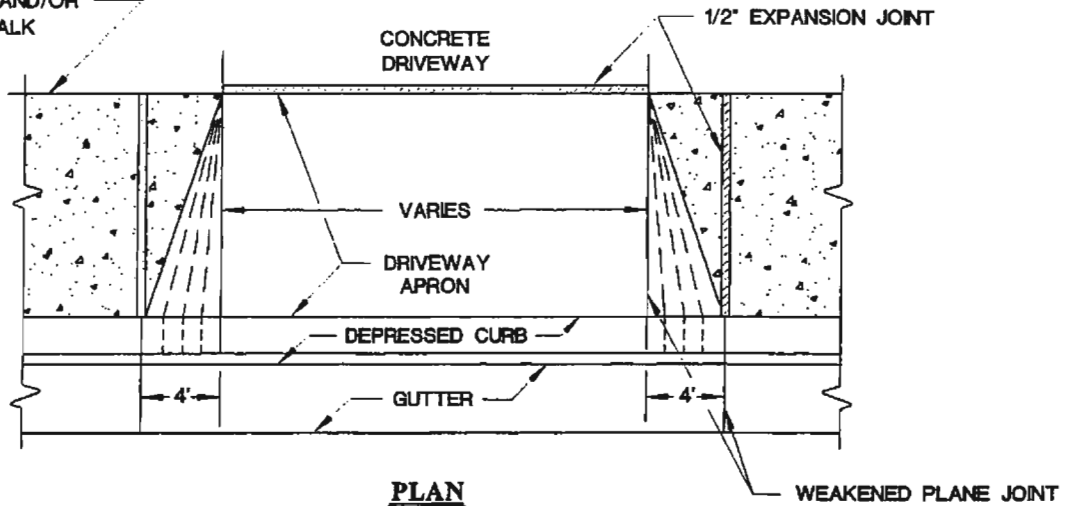

**NOTES:**

1. WHEN CONSTRUCTING DRIVEWAY WHERE CURB AND GUTTER EXISTS, COMPLETELY REMOVE INTERFERING PORTIONS OF EXISTING CURB AND GUTTER. DRIVEWAYS MAY BE MONOLITHIC TO A.C. LINE.
2. WEAKENED PLANE JOINTS SHALL BE UNIFORMLY PLACED BETWEEN 5' AND 7' INTERVALS, SEE STANDARD DRAWING NO. 234.

SPECIFICATION REFERENCE		UNIFORM STANDARD DRAWINGS CLARK COUNTY AREA		
302	AGGREGATE BASE	RESIDENTIAL DRIVEWAY		
501	CONCRETE			
502	CONCRETE STRUCTURES			
707	JOINT MATERIAL			
		DATE 12-14-00	DWG. NO. 223	PAGE NO. 29

PROPERTY LINE AND/OR  
BACK OF SIDEWALK

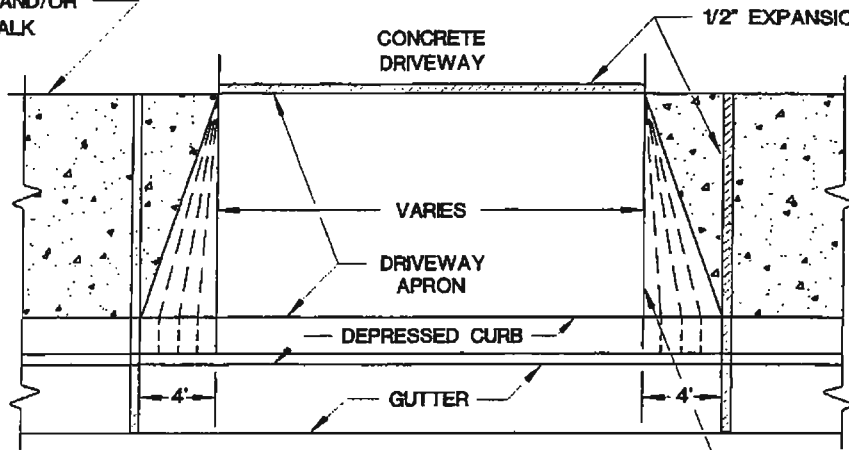

**PLAN**

1/2" EXPANSION JOINT BOTH SIDES

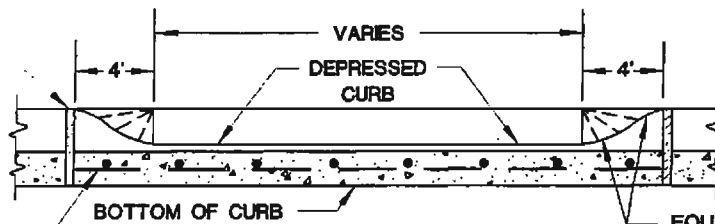

**ELEVATION**

PROPERTY LINE AND/OR  
BACK OF SIDEWALK

CONCRETE DRIVEWAY

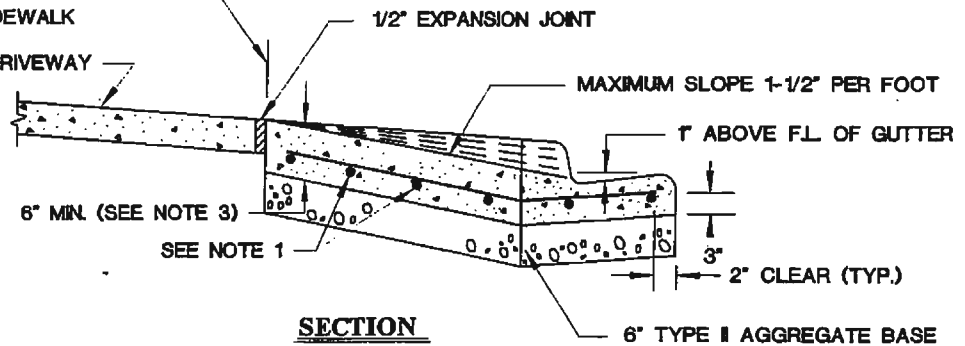

**SECTION**

**NOTES:**

1. NO. 4 BARS AT 16" O.C. BOTH WAYS EXTENDING INTO GUTTER. NO. 4 BARS SHALL BE PLACED 3" ABOVE BOTTOM OF CONCRETE SUPPORTED BY NON-FERROUS CHAIRS APPROVED BY THE ENGINEER.
2. WHEN CONSTRUCTING DRIVEWAY WHERE CURB AND GUTTER EXISTS, COMPLETELY REMOVE INTERFERING PORTIONS OF EXISTING CURB AND GUTTER. DRIVEWAY SHALL BE MONOLITHIC TO A.C. LINE.
3. DRIVEWAY THICKNESS FOR INDUSTRIAL USE SHALL BE 8" MIN.
4. WEAKENED PLANE JOINTS SHALL BE EQUALLY SPACED AT 15' MAX. INTERVALS, SEE STANDARD DRAWING NO. 234.

SPECIFICATION REFERENCE		UNIFORM STANDARD DRAWINGS CLARK COUNTY AREA		
302	AGGREGATE BASE	<b>COMMERCIAL AND INDUSTRIAL DRIVEWAY (OPTION A)</b>		
501	CONCRETE			
502	CONCRETE STRUCTURES			
505	REINFORCING STEEL			
707	JOINT MATERIAL			
		DATE 12-14-00	DWG. NO. 224	PAGE NO. 30

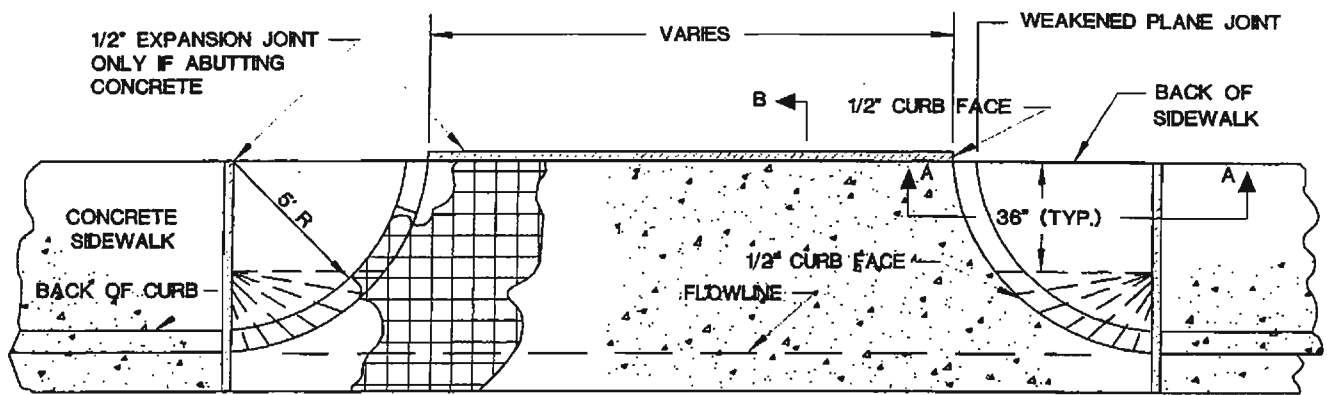

**PLAN**

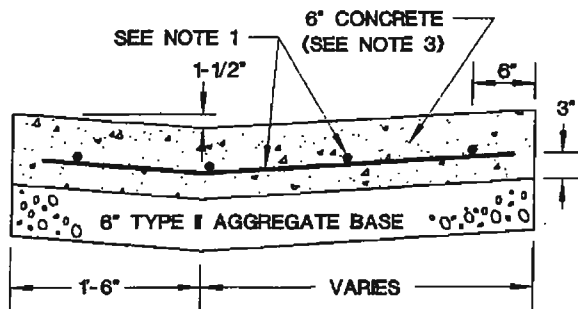

**SECTION B-B**

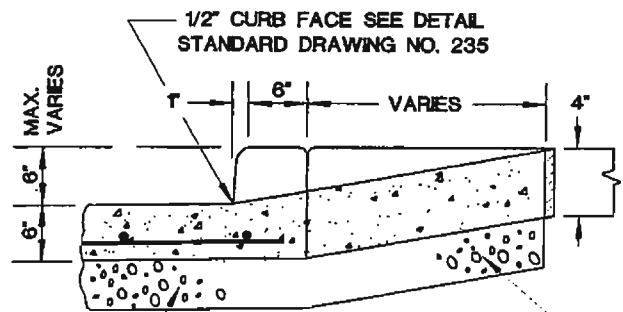

6" MIN. TYPE II AGGREGATE BASE

5" MIN. TYPE II AGGREGATE BASE

**SECTION A-A**

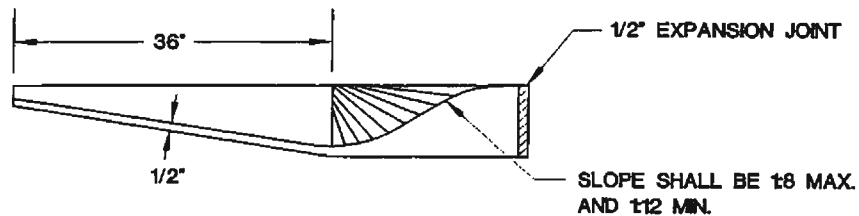

**WHEELCHAIR RAMP CURB FACE PROFILE**

1. NO. 4 BARS AT 16" O.C. BOTH WAYS EXTENDING INTO GUTTER. NO. 4 BARS SHALL BE PLACED 3" ABOVE BOTTOM OF CONCRETE SUPPORTED BY NON-FERROUS CHAIRS APPROVED BY THE ENGINEER.
2. WHEN CONSTRUCTING DRIVEWAY WHERE CURB AND GUTTER EXISTS, COMPLETELY REMOVE INTERFERING PORTIONS OF EXISTING CURB AND GUTTER. DRIVEWAY SHALL BE MONOLITHIC TO A.C. LINE.
3. DRIVEWAY THICKNESS FOR INDUSTRIAL USE SHALL BE 8" MIN.
4. WEAKENED PLANE JOINTS SHALL BE EQUALLY SPACED AT 15' MAX. INTERVALS.
5. THIS DRIVEWAY DESIGN SHALL ALSO BE USED FOR ALLEY INTERSECTIONS, 8" MIN. THICKNESS.
6. SPECIAL DESIGNS SUBJECT TO APPROVAL OF THE ENGINEER.

SPECIFICATION REFERENCE		UNIFORM STANDARD DRAWINGS CLARK COUNTY AREA		
302	AGGREGATE BASE	(ALLOWABLE IN NORTH LAS VEGAS ONLY) COMMERCIAL AND INDUSTRIAL DRIVEWAY (OPTION C)		
501	CONCRETE			
502	CONCRETE STRUCTURES			
505	REINFORCING STEEL			
707	JOINT MATERIAL			
		DATE 12-14-00	DWG. NO. 226	PAGE NO. 32

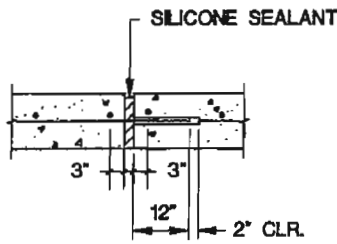
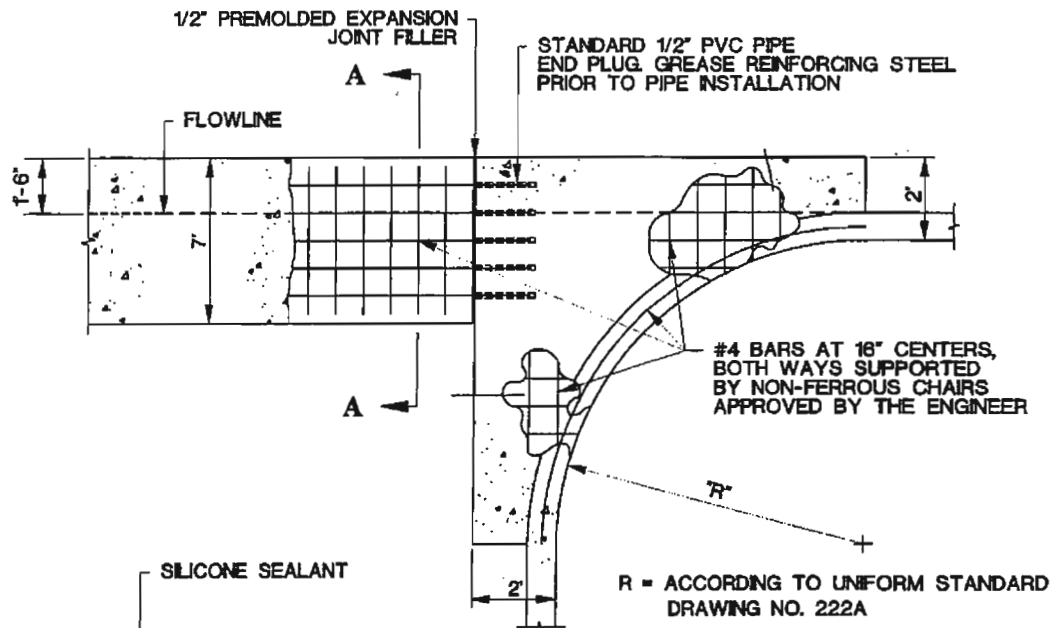

**JOINT DETAIL**

R = ACCORDING TO UNIFORM STANDARD DRAWING NO. 222A

**PLAN**

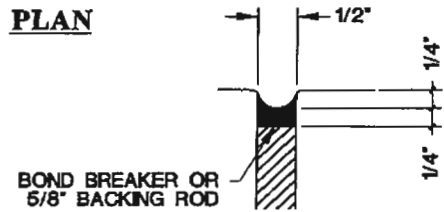

**SEALANT DETAIL**

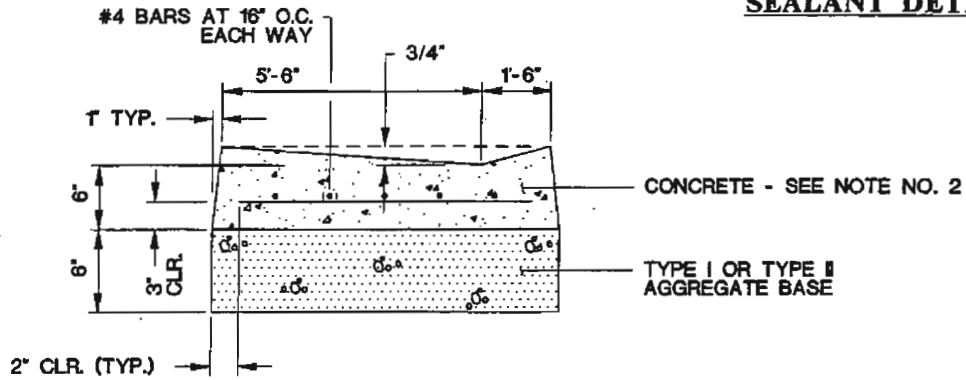

**SECTION A-A**

**NOTES:**

1. FINISHED ASPHALT CONCRETE SURFACE TO BE FLUSH WITH CROSS GUTTER LIP.
2. ADJACENT SPANDREL SHALL BE 6" THICK P.C.C.

<b>SPECIFICATION REFERENCE</b>		<b>UNIFORM STANDARD DRAWINGS CLARK COUNTY AREA</b>		
302	AGGREGATE BASE			
501	CONCRETE	(HENDERSON ONLY)		
502	CONCRETE STRUCTURES	<b>LIGHT DUTY COMMERCIAL DRIVEWAY</b>		
505	REINFORCING STEEL	(OFFICES, CHURCHES, SCHOOLS, RESTAURANTS, ETC.)		
707	EXPANSION JOINT MATERIAL			
TT-S-00153A CLASS A SEALANT		DATE 12-14-00	DWG. NO. 226.1	PAGE 32.1

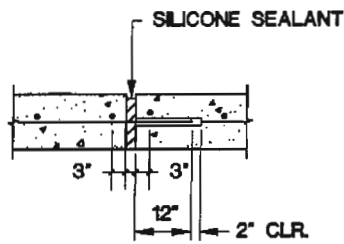
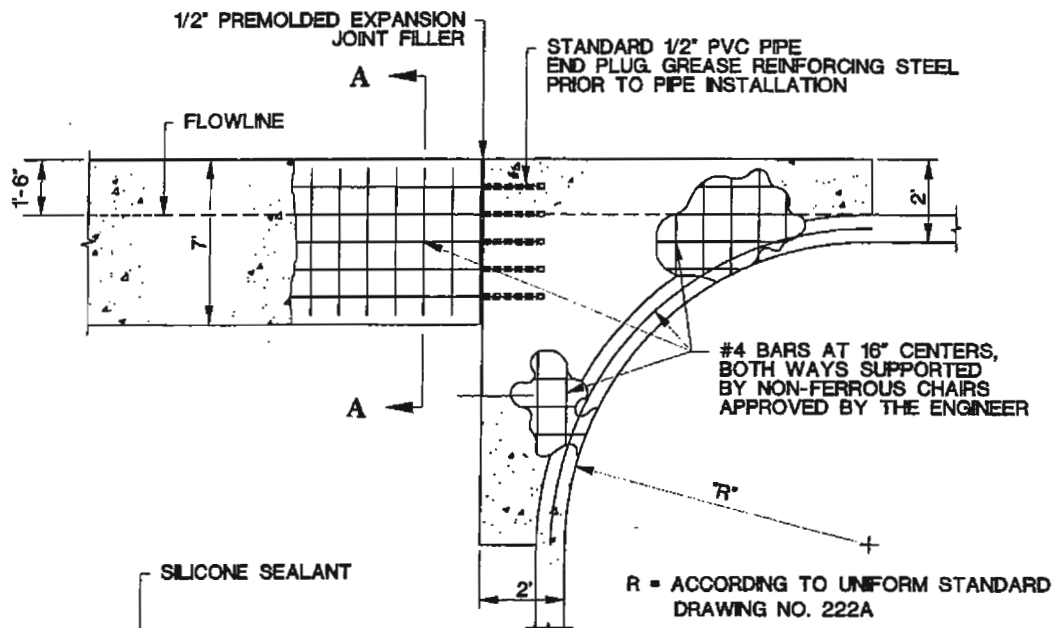

**JOINT DETAIL**

**PLAN**

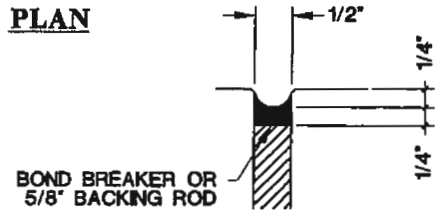

**SEALANT DETAIL**

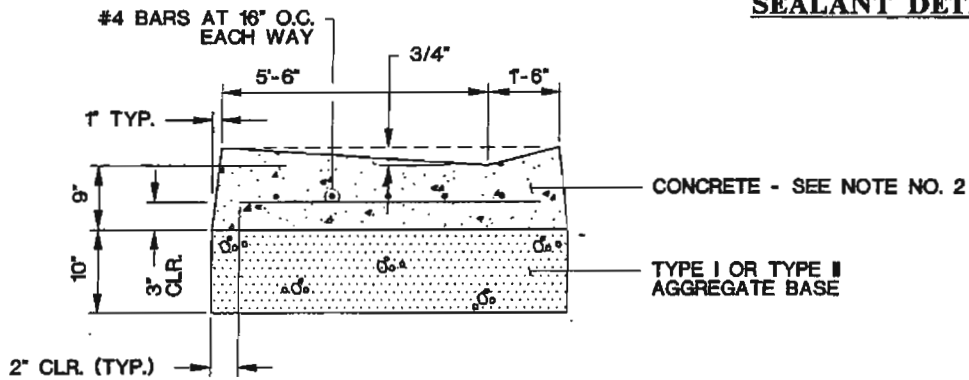

**SECTION A-A**

**NOTES:**

1. FINISHED ASPHALT CONCRETE SURFACE TO BE FLUSH WITH CROSS GUTTER LP.
2. ADJACENT SPANDREL SHALL BE 9" THICK P.C.C.

<b>SPECIFICATION REFERENCE</b>		<b>UNIFORM STANDARD DRAWINGS CLARK COUNTY AREA</b>	
302	AGGREGATE BASE	(HENDERSON ONLY)	
501	CONCRETE	<b>HEAVY DUTY COMMERCIAL DRIVEWAY</b>	
502	CONCRETE STRUCTURES	(SERVICE STATIONS, INDUSTRIAL, LOADING DOCKS, ETC.)	
505	REINFORCING STEEL		
707	EXPANSION JOINT MATERIAL		
TT-S-00153A CLASS A SEALANT		DATE 12-14-00	DWG. NO. 226.2 PAGE 32.2

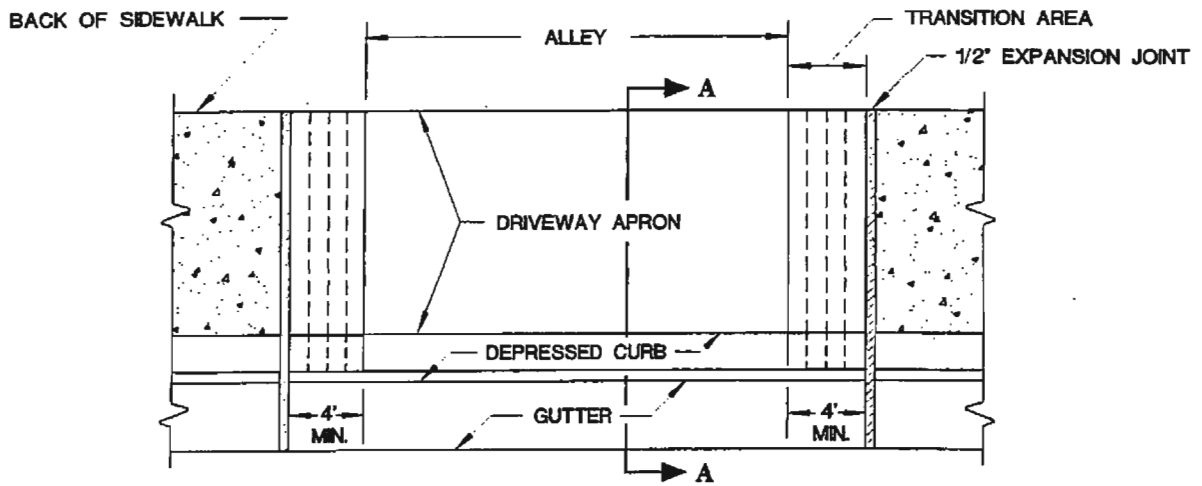

**PLAN**

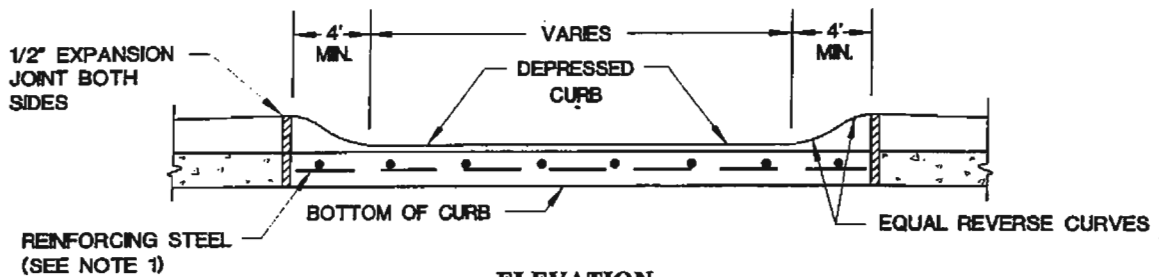

**ELEVATION**

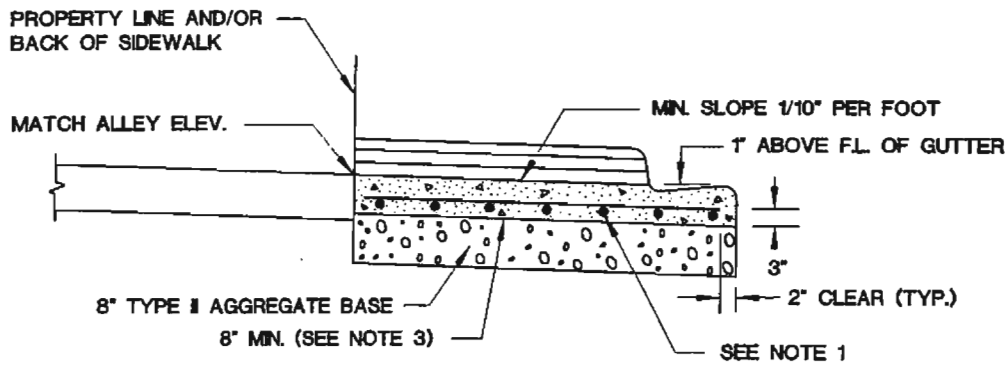

**SECTION A-A**

**NOTES:**

1. NO. 4 BARS AT 16" O.C. BOTH WAYS CONTINUOUS THROUGH GUTTER. NO. 4 BARS SHALL BE PLACED 3" ABOVE BOTTOM OF CONCRETE.
2. WHEN CONSTRUCTING DRIVEWAY WHERE CURB AND GUTTER EXISTS, COMPLETELY REMOVE INTERFERING PORTIONS OF EXISTING CURB AND GUTTER. DRIVEWAY SHALL BE MONOLITHIC TO A.C. LINE.
3. DRIVEWAY THICKNESS SHALL BE 8" MIN.

<b>SPECIFICATION REFERENCE</b>	<b>UNIFORM STANDARD DRAWINGS CLARK COUNTY AREA</b>		
	CITY OF LAS VEGAS ONLY		
	DEPRESSED ALLEY DRIVEWAY		
	DATE 12-14-00	DWG. NO. 227	PAGE NO. 33

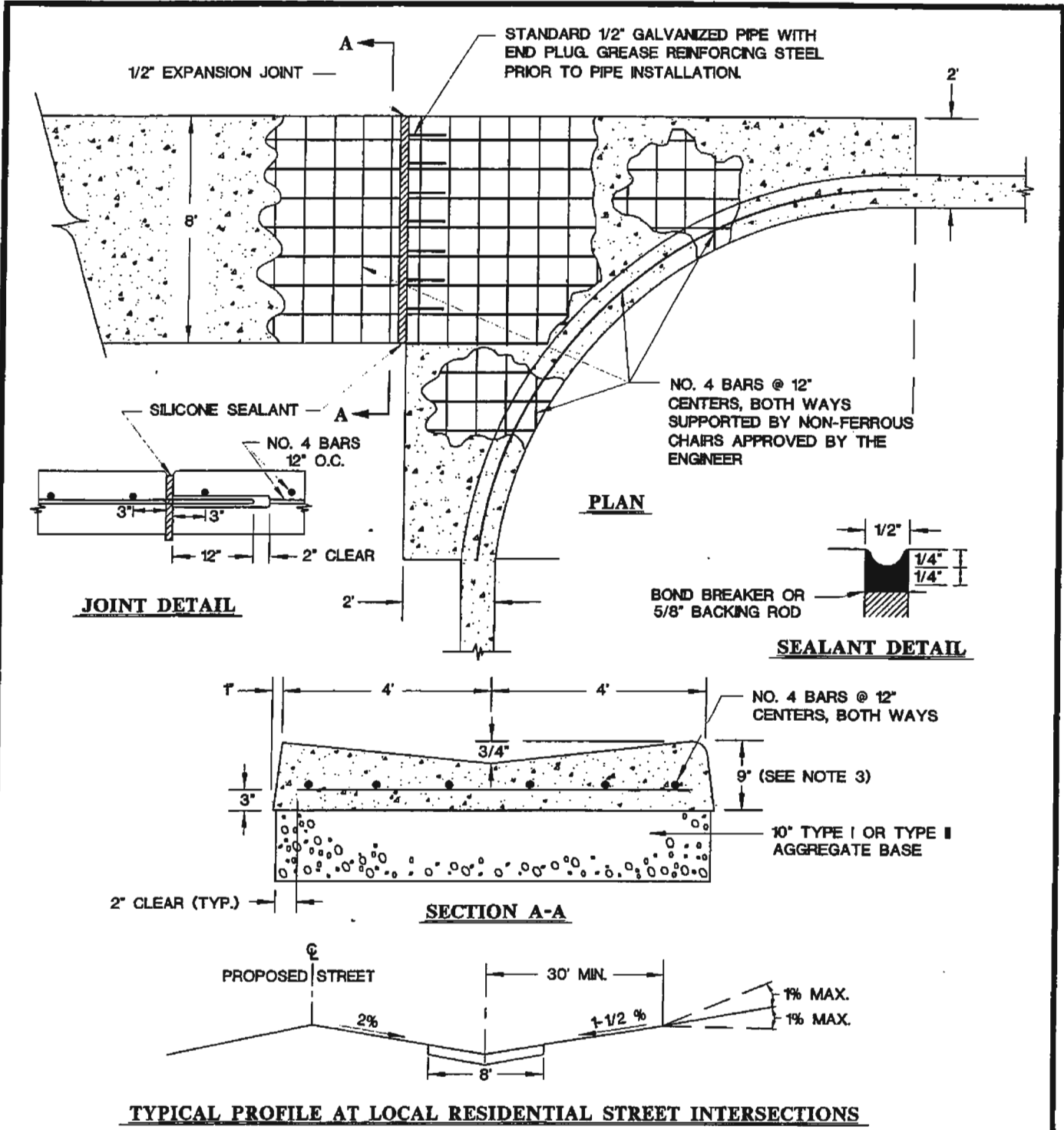

**NOTES:**

1. FINISHED ASPHALT CONCRETE SURFACE TO BE FLUSH WITH CROSS GUTTER LIP.
2. CONSTRUCTION OF CROSS GUTTER IS NOT ALLOWED ACROSS MAJOR COLLECTOR OR ARTERIAL STREETS.
3. ADJACENT SPANDREL SHALL BE 9" THICK P.C.C.

<b>SPECIFICATION REFERENCE</b>		<b>UNIFORM STANDARD DRAWINGS CLARK COUNTY AREA</b>		
302	AGGREGATE BASE			
501	CONCRETE	<b>CROSS GUTTER</b>		
502	CONCRETE STRUCTURES			
505	REINFORCING STEEL			
707	EXPANSION JOINT MATERIAL			
TT-S-00153A CLASS A SEALANT				
DATE 12-14-00	DWG. NO.	228	PAGE NO.	34

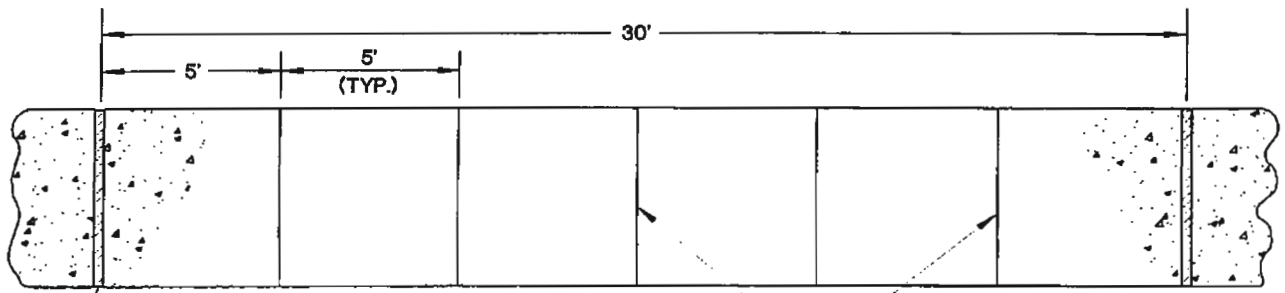

1/2" EXPANSION JOINT AT 30' INTERVALS, AT COLD JOINTS AND AT BEGINNING AND END OF RETURN. EXPANSION JOINTS TO MATCH LOCATION MATCH LOCATION OF CURB AND GUTTER EXPANSION JOINT.

**PLAN**

WEAKENED PLANE JOINT

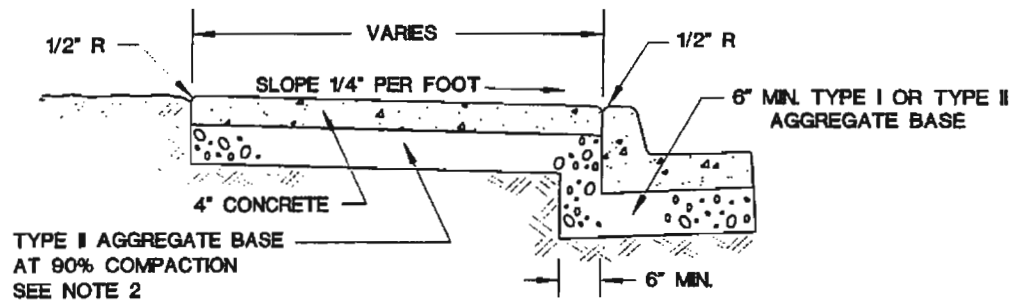

**TYPICAL SECTION**

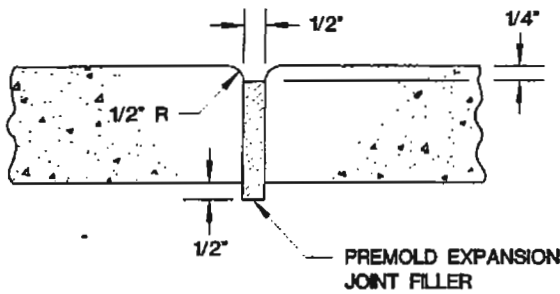

**EXPANSION JOINT**

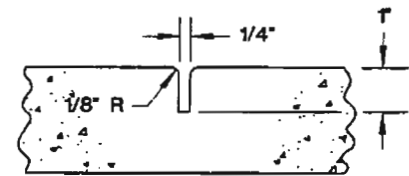

**WEAKENED PLANE JOINT**

**NOTES:**

1. ON ALL CURB RETURNS A 1/2" EXPANSION JOINT SHALL BE CONSTRUCTED BETWEEN THE BACK OF CURB AND THE SIDEWALK FOR THE ENTIRE LENGTH OF THE RETURN.
2. THE TYPE II AGGREGATE BASE THICKNESS IS SHOWN ON THE TYPICAL SECTION DRAWINGS 202 - 207.
3. LONGITUDINAL WEAKENED PLANE JOINT REQUIRED AT MIDPOINT OF SIDEWALK 10' OR WIDER.

SPECIFICATION REFERENCE		UNIFORM STANDARD DRAWINGS CLARK COUNTY AREA		
302	AGGREGATE BASE	<b>SIDEWALK</b>		
501	CONCRETE			
502	CONCRETE STRUCTURES			
707	JOINT MATERIAL			
		DATE 12-14-00	DWG. NO. 234	PAGE NO. 40



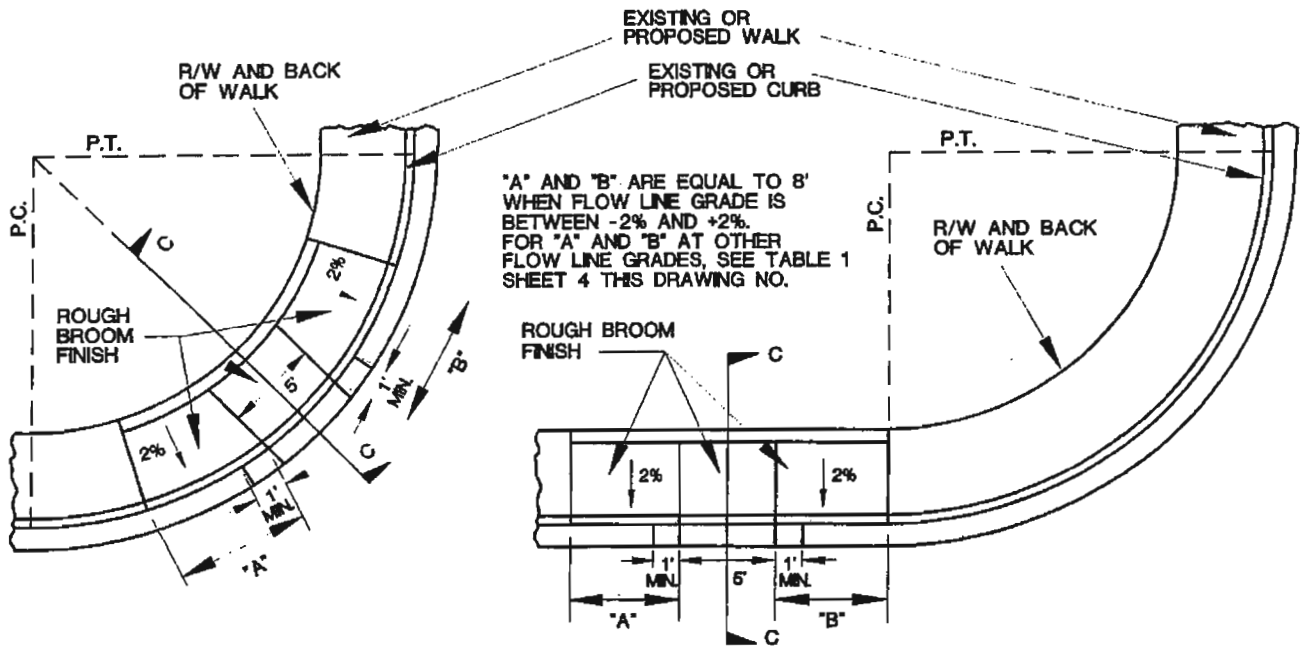

**RAMP IN CURB RETURN**

**RAMP OUTSIDE CURB RETURN**

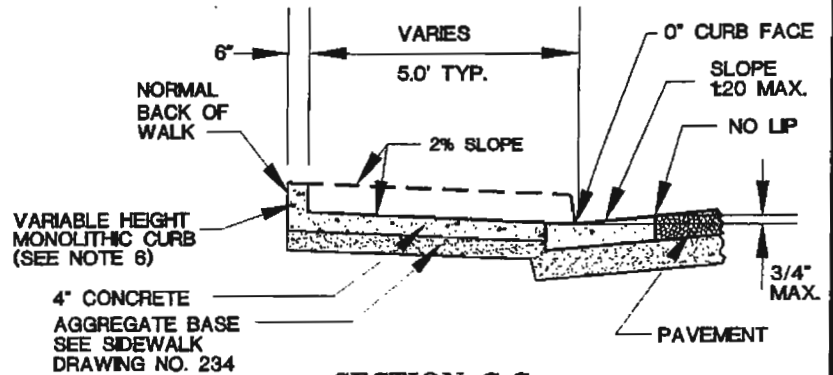

**SECTION C-C**

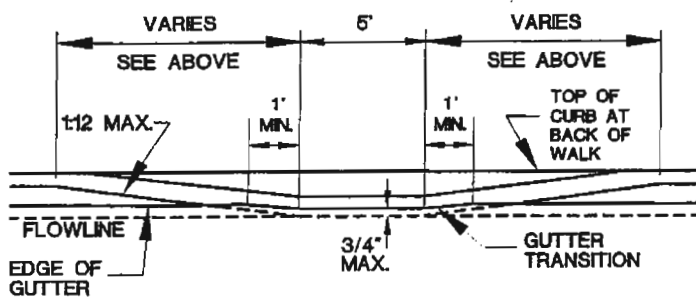

**PROFILE**

**NOTES:**

1. SIDEWALK RAMP WITHIN CURB RETURN SHALL BE LOCATED AT THE MIDPOINT OF CURB RETURN UNLESS OTHERWISE APPROVED.
2. SIDEWALK RAMPS OUTSIDE OF THE CURB RETURN SHALL BE LOCATED ADJACENT TO THE RETURN UNLESS OTHERWISE APPROVED.
3. RAMPS SHALL BE CONSTRUCTED WITH A ROUGH BROOM FINISH TRANSVERSE TO THE SLOPE OF THE RAMP.
4. WHEN CONSTRUCTING RAMP WHERE CURB & GUTTER EXISTS, COMPLETELY REMOVE INTERFERING PORTIONS OF EXISTING CURB & GUTTER.
5. DETECTABLE WARNING CONSISTING OF RAISED TRUNCATED DOMES WITH A DIAMETER OF NOMINAL 0.9 IN, A HEIGHT OF NOMINAL 0.2 IN, AND A CENTER-TO-CENTER SPACING OF NOMINAL 2.35 IN AND CONTRASTING VISUALLY WITH ADJOINING SURFACES MAY BE PLACED ON RAMP EXTENDING THE FULL WIDTH AND DEPTH OF THE RAMP.
6. CURB MAY BE PLACED AND IS PREFERRED BEHIND BACK OF WALK IF SUFFICIENT RIGHT-OF-WAY OR EASEMENTS EXIST AND AS APPROVED BY THE ENGINEER.

SPECIFICATION REFERENCE	
302	AGGREGATE BASE
501	CONCRETE
502	CONCRETE STRUCTURES

**UNIFORM STANDARD DRAWINGS  
CLARK COUNTY AREA**

**SIDEWALK RAMP  
CASE I**

DATE 12-14-00	DWG. NO. 235 (1 OF 4)	PAGE 41
---------------	-----------------------	---------

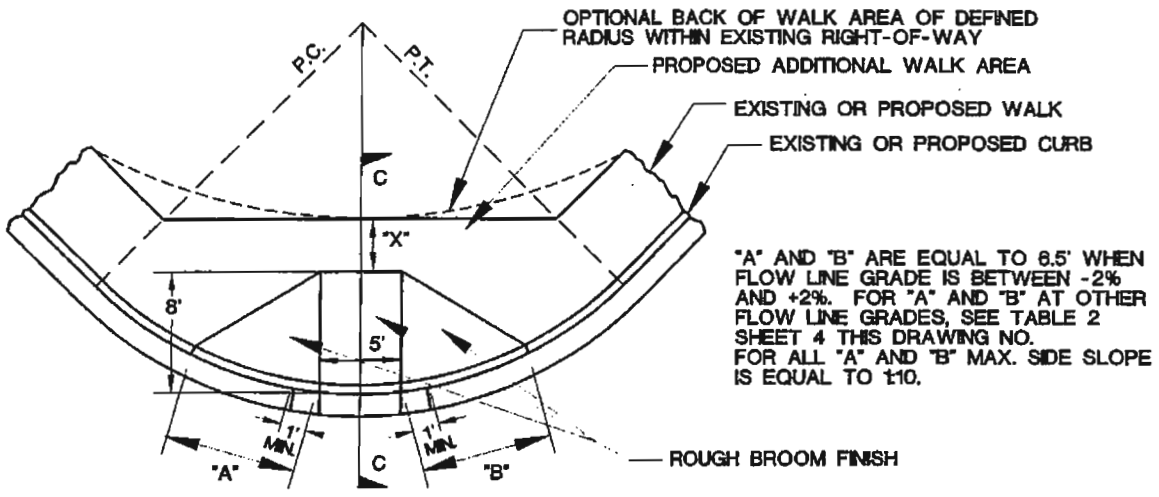

**RAMP IN CURB RETURN**  
(NO BACK OF WALK DEPRESSION)

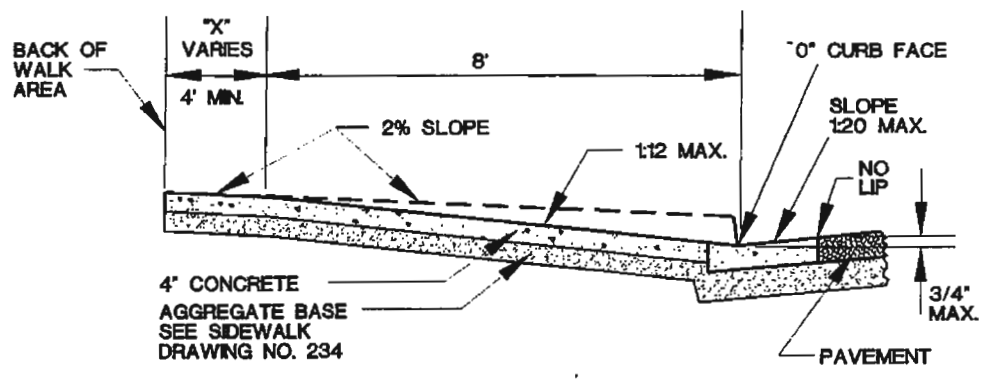

**SECTION C-C**

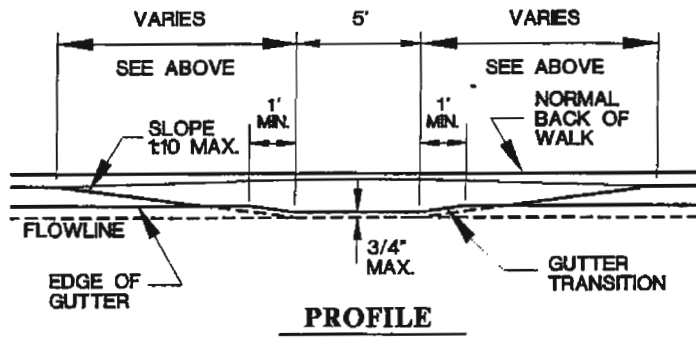

**PROFILE**

**NOTES:**

1. SIDEWALK RAMP WITHIN CURB RETURN SHALL BE LOCATED AT THE MIDPOINT OF CURB RETURN UNLESS OTHERWISE APPROVED.
2. RAMPS SHALL BE CONSTRUCTED WITH A ROUGH BROOM FINISH TRANSVERSE TO THE SLOPE OF THE RAMP.
3. WHEN CONSTRUCTING RAMP WHERE CURB & GUTTER EXISTS, COMPLETELY REMOVE INTERFERING PORTIONS OF EXISTING CURB & GUTTER.
4. DETECTABLE WARNING CONSISTING OF RAISED TRUNCATED DOMES WITH A DIAMETER OF NOMINAL 0.9 IN., A HEIGHT OF NOMINAL 0.2 IN. AND A CENTER-TO-CENTER SPACING OF NOMINAL 2.35 IN. AND CONTRASTING VISUALLY WITH ADJOINING SURFACES MAY BE PLACED ON RAMP EXTENDING THE FULL WIDTH AND DEPTH OF THE RAMP.

CASE II SHALL BE USED WHERE R/W AND FIELD CONDITIONS PERMIT.

SPECIFICATION REFERENCE		UNIFORM STANDARD DRAWINGS CLARK COUNTY AREA		
302	AGGREGATE BASE			
501	CONCRETE	SIDEWALK RAMP CASE II		
502	CONCRETE STRUCTURES			
		DATE 12-14-00	DWG. NO. 235 (2 OF 4)	PAGE 41A

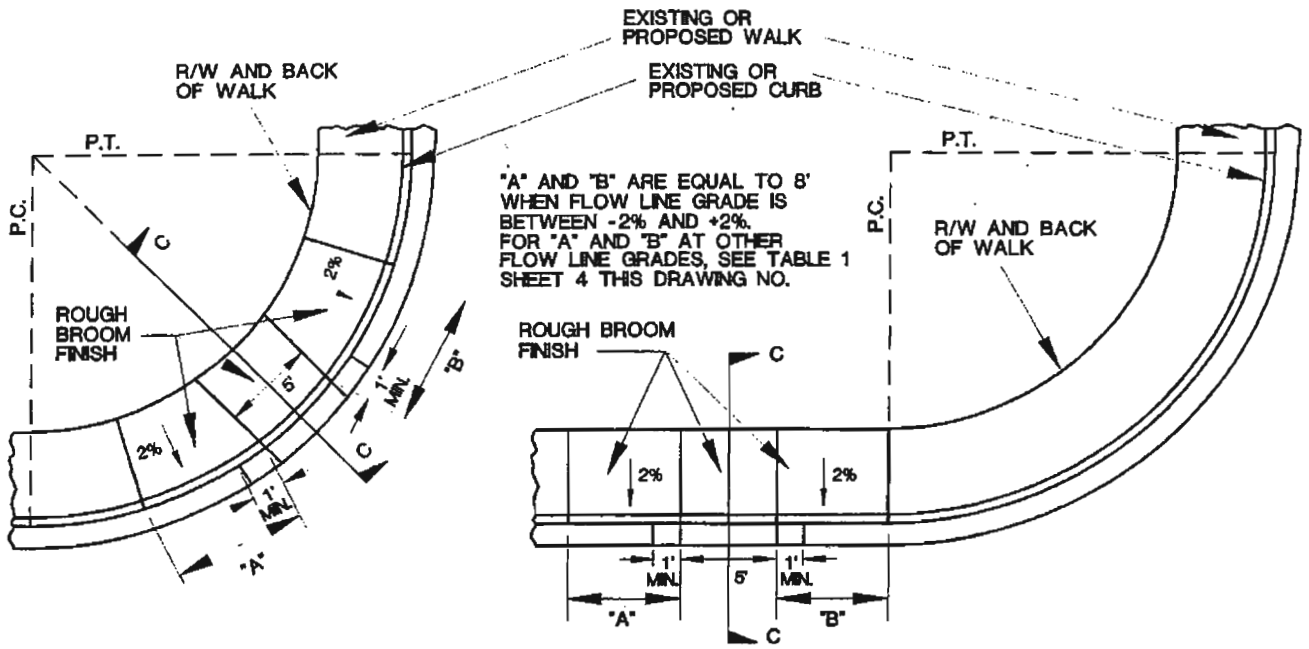

**RAMP IN CURB RETURN**

**RAMP OUTSIDE CURB RETURN**

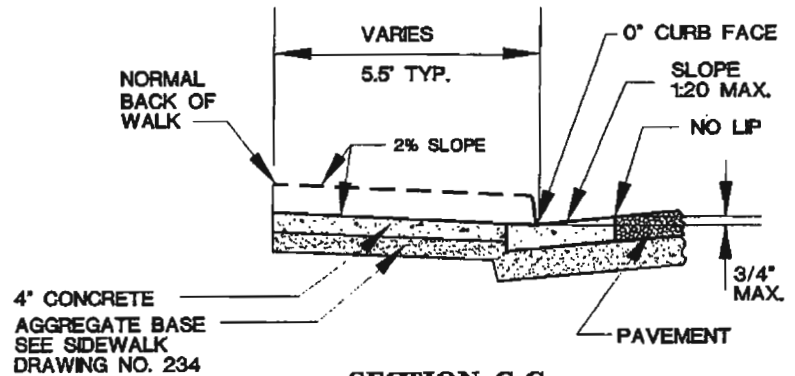

**SECTION C-C**

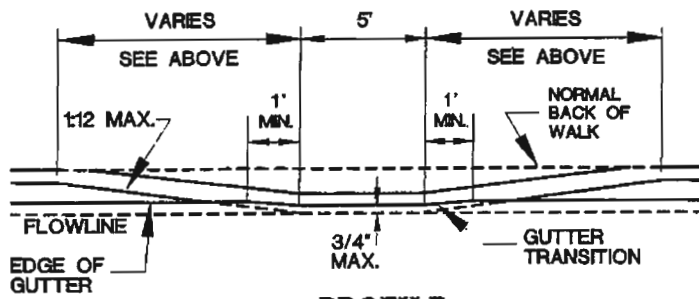

**PROFILE**

**CASE III TO BE USED FOR AREAS WHERE OBSTRUCTION (I.E. BLOCK WALL) EXISTS AT BACK OF WALK ONLY WHEN APPROVED BY THE ENGINEER.**

**NOTES:**

1. SIDEWALK RAMP WITHIN CURB RETURN SHALL BE LOCATED AT THE MIDPOINT OF CURB RETURN UNLESS OTHERWISE APPROVED.
2. SIDEWALK RAMP OUTSIDE OF THE CURB RETURN SHALL BE LOCATED ADJACENT TO THE RETURN UNLESS OTHERWISE APPROVED.
3. RAMPS SHALL BE CONSTRUCTED WITH A ROUGH BROOM FINISH TRANSVERSE TO THE SLOPE OF THE RAMP.
4. WHEN CONSTRUCTING RAMP WHERE CURB & GUTTER EXISTS, COMPLETELY REMOVE INTERFERING PORTIONS OF EXISTING CURB & GUTTER.
5. DETECTABLE WARNING CONSISTING OF RAISED TRUNCATED DOMES WITH A DIAMETER OF NOMINAL 0.9 IN., A HEIGHT OF NOMINAL 0.2 IN. AND A CENTER-TO-CENTER SPACING OF NOMINAL 2.35 IN. AND CONTRASTING VISUALLY WITH ADJOINING SURFACES MAY BE PLACED ON RAMP EXTENDING THE FULL WIDTH AND DEPTH OF THE RAMP.

<b>SPECIFICATION REFERENCE</b>		<b>UNIFORM STANDARD DRAWINGS CLARK COUNTY AREA</b>		
302	AGGREGATE BASE	<b>SIDEWALK RAMP CASE III</b>		
501	CONCRETE			
502	CONCRETE STRUCTURES			
		DATE 12-14-00	DWG. NO. 235 (3 OF 4)	PAGE 41B

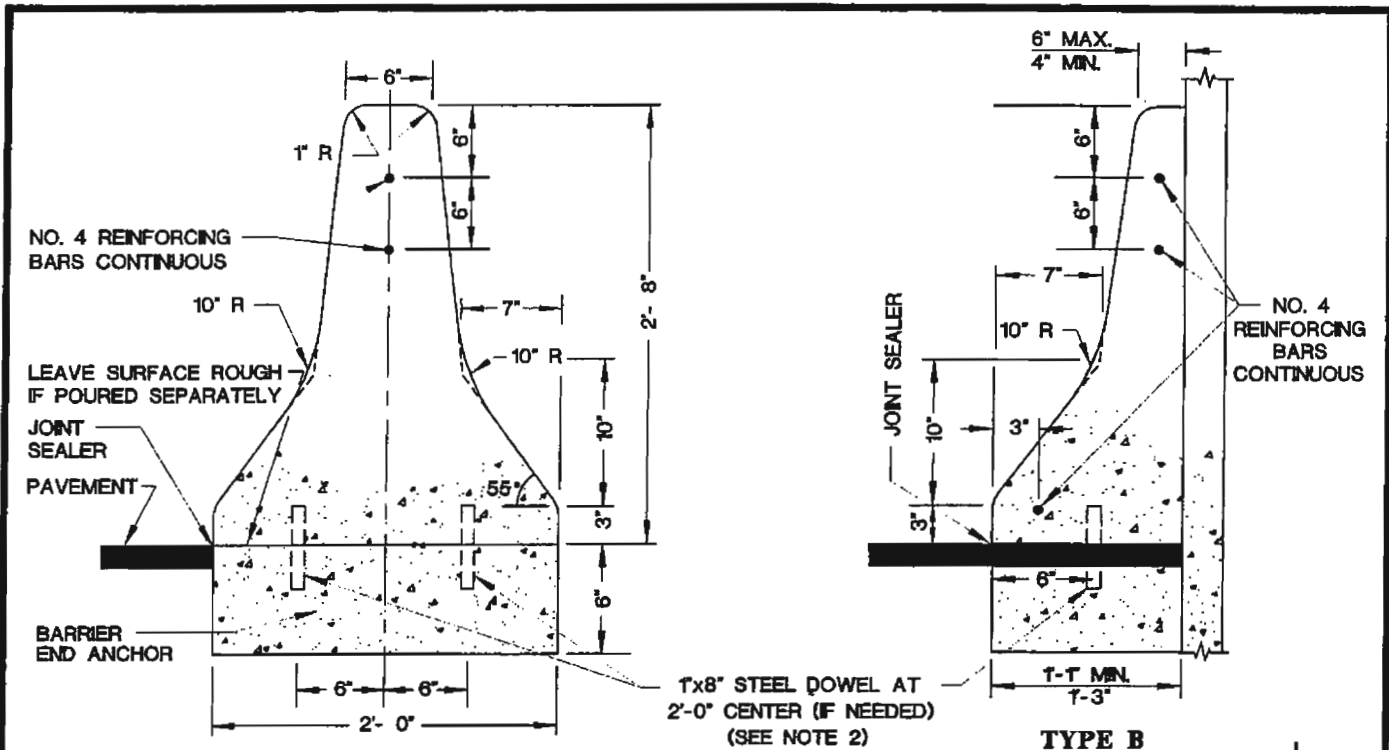

**TYPE A**

**TYPE B**

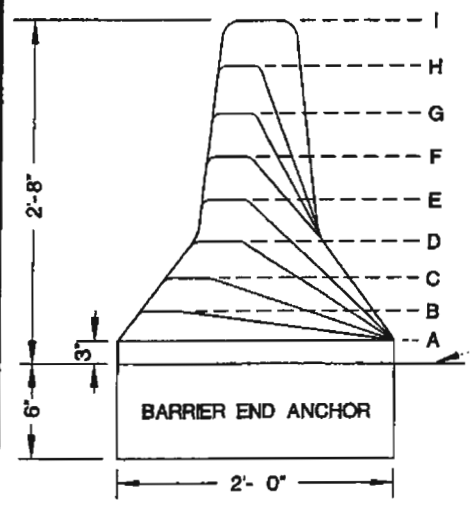

**TRANSITION DETAIL**

**CONCRETE BARRIER RAIL FLARE RATES**

OPERATING SPEED	FLARE RATE
60	17:1 MAX
50	14:1
40	11:1

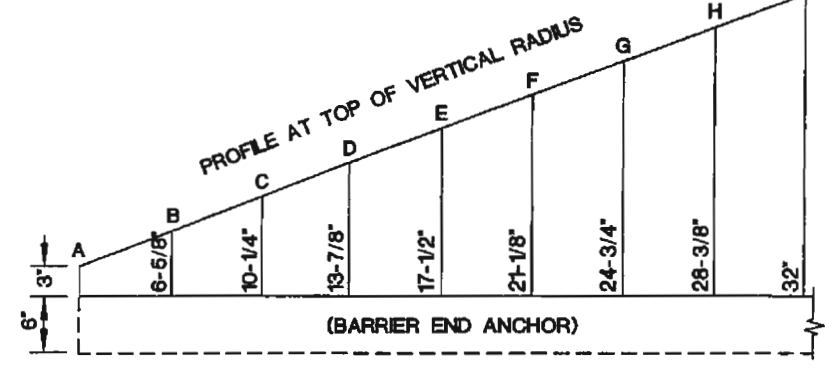

**TRANSITION OF END OF BARRIER**  
TO BE USED ONLY IF END IS FLARED

**NOTES:**

1. TRANSVERSE JOINTS WITH 1" PREMOLDED EXPANSION JOINT FILLER OR 1" OPEN TRANSVERSE JOINTS SHALL BE PLACED AT STRUCTURES. JOINTS IN BARRIER RAIL OVER A STRUCTURE SHALL BE AT THE SAME LOCATION AND OF THE SAME DIMENSION AS THOSE IN THE STRUCTURE.
2. BITUMINOUS PAVING REQUIRED: PAVING SHALL BUTT AGAINST THE BARRIER RAIL END ANCHOR SECTION AND SHALL EXTEND FULL WIDTH UNDER THE NORMAL BARRIER RAIL SECTION PLUS 6" MINIMUM 6-INCH DEEP BARRIER. END ANCHORS SHALL BE CONSTRUCTED IN THE FIRST AND LAST 10 LINEAR FEET OF THE FULL HEIGHT BARRIER RAIL RUN. IF TRANSITIONS ARE USED, THE ANCHOR SHALL BE EXTENDED UNDER THE TRANSITION.

SPECIFICATION REFERENCE		UNIFORM STANDARD DRAWINGS CLARK COUNTY AREA		
501	CONCRETE	<b>CONCRETE BARRIER RAIL</b>		
502	CONCRETE STRUCTURES			
		DATE 12-14-00	DWG. NO. 237	PAGE NO. 43

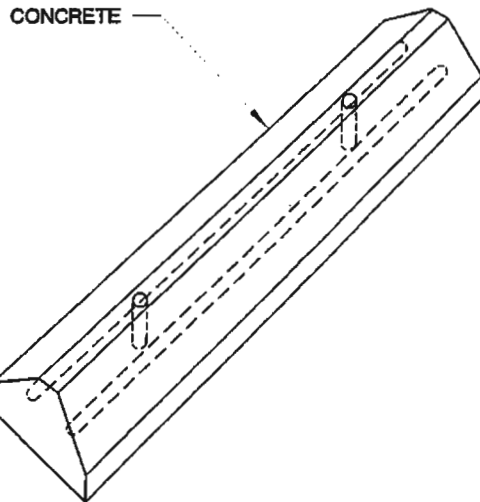

**NOTES:**

1. PRECAST BUMPER BLOCK TO BE USED IN PARKING LOTS ONLY.
2. GROUT HOLE BEFORE DRIVING SPIKE. AFTER DRIVING SPIKE, FILL HOLE WITH CONCRETE MORTAR AND FINISH FLUSH WITH TOP.

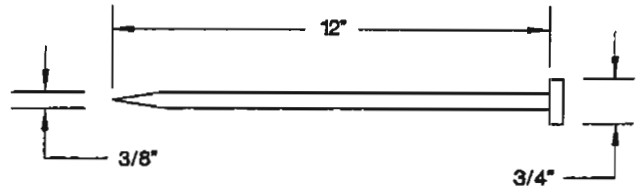

**STEEL WIRE BRIDGE SPIKE**

1/2" DEFORMED BAR TO STAY  $\tau$  MIN. INSIDE CONCRETE

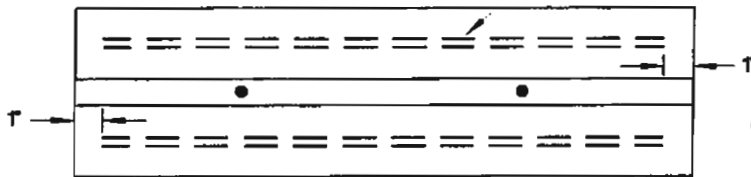

**TOP VIEW**

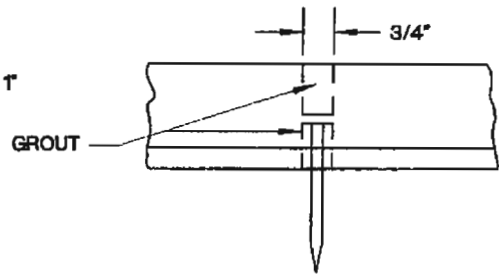

**HOLE DETAIL**

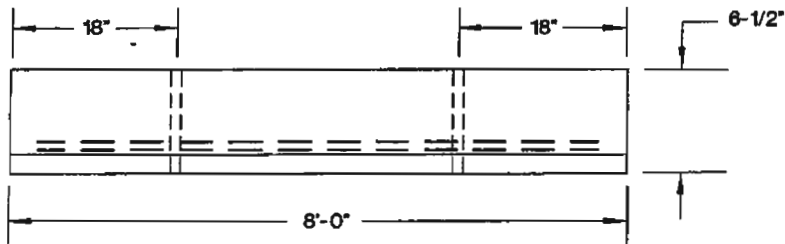

**SIDE VIEW**

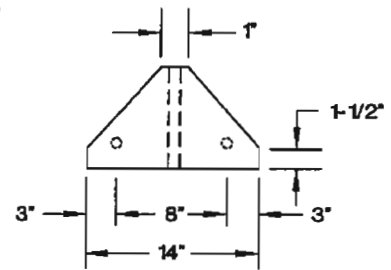

**END VIEW**

<b>SPECIFICATION REFERENCE</b>		<b>UNIFORM STANDARD DRAWINGS CLARK COUNTY AREA</b>	
501	CONCRETE		
505	REINFORCING STEEL	<b>PRECAST BUMPER BLOCK</b>	
DATE 12-14-00		DWG. NO. 238	PAGE NO. 44

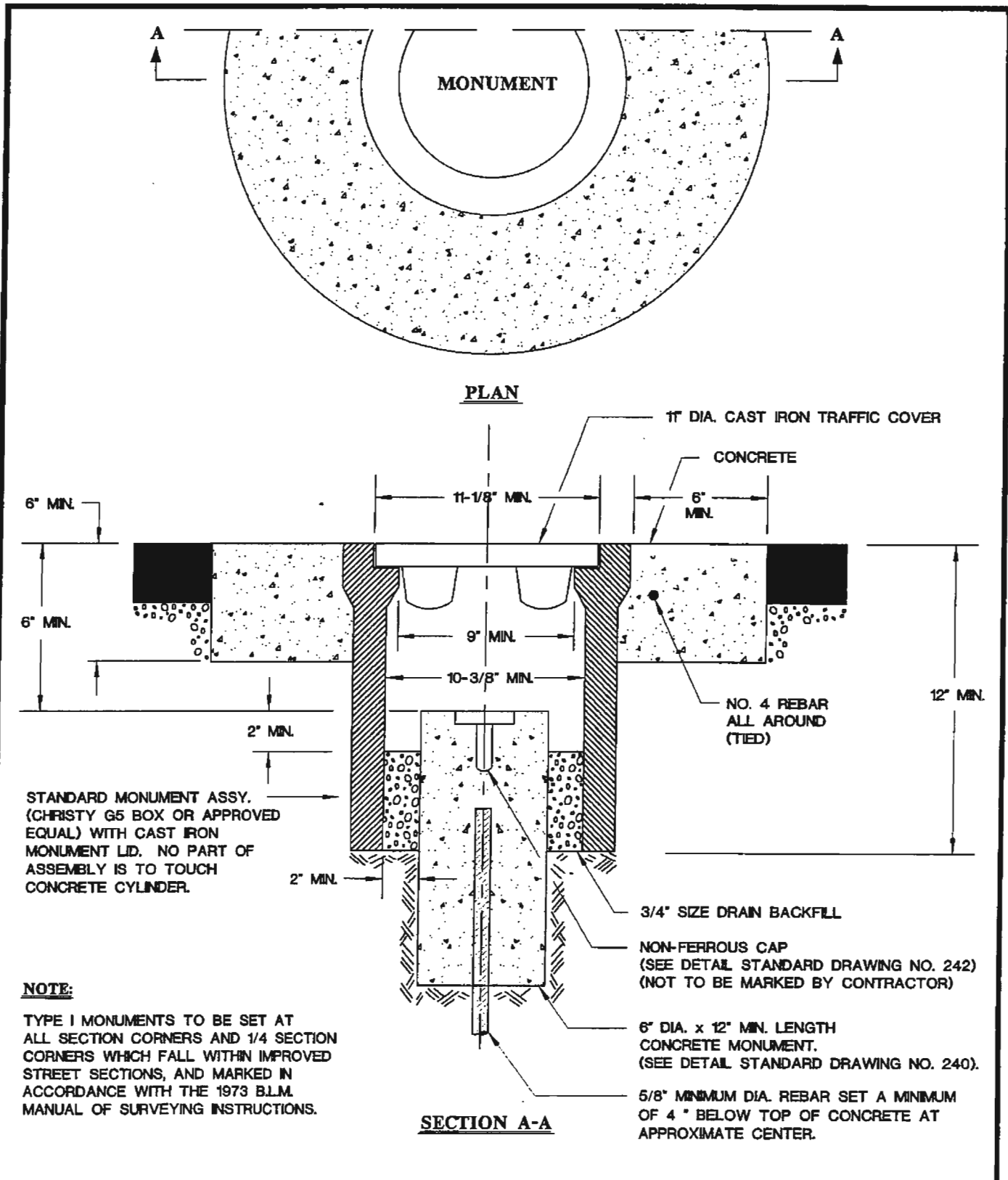

**NOTE:**

TYPE I MONUMENTS TO BE SET AT ALL SECTION CORNERS AND 1/4 SECTION CORNERS WHICH FALL WITHIN IMPROVED STREET SECTIONS, AND MARKED IN ACCORDANCE WITH THE 1973 B.L.M. MANUAL OF SURVEYING INSTRUCTIONS.

SPECIFICATION REFERENCE		UNIFORM STANDARD DRAWINGS CLARK COUNTY AREA	
501	CONCRETE	TYPE I MONUMENT	
621	MONUMENTS		
704	BASE AGGREGATE		
		DATE 12-14-00	DWG. NO. 239
			PAGE NO. 45

**NOTES:**

1. TYPE II-A MONUMENTS TO BE SET AT ALL SECTION CORNERS, 1/4 SECTION CORNERS AND 1/16 SECTION CORNERS WHICH FALL WITHIN UNIMPROVED STREET SECTIONS.
2. TYPE II-B MONUMENTS TO BE SET AT ALL 1/16 SECTION CORNERS WHICH FALL WITHIN IMPROVED STREET SECTIONS.
3. ALL TYPE II MONUMENTS ARE TO BE MARKED IN ACCORDANCE WITH THE 1973 B.L.M. MANUAL OF SURVEYING INSTRUCTIONS.
4. 6" x 6" SQUARE MONUMENTS ARE ALSO ACCEPTABLE.
5. IF MONUMENTS ARE TO BE "PRECAST" THEY ARE TO BE EMBEDDED IN FRESH CONCRETE TO PREVENT MOVEMENT.
6. THE COUNTY/CITY SURVEYOR MAY REQUIRE TYPE II MONUMENTS IN ADDITIONAL LOCATIONS.

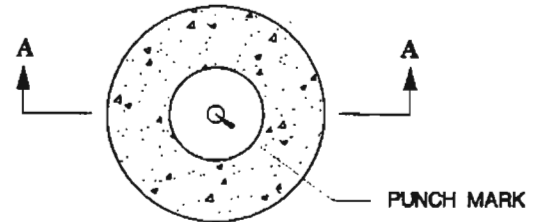

**PLAN**

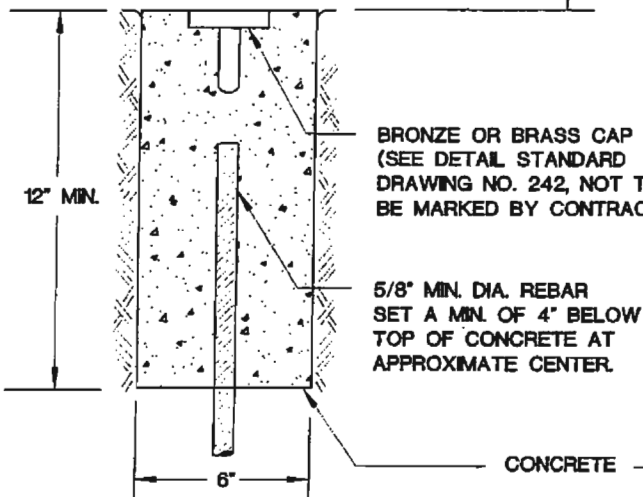
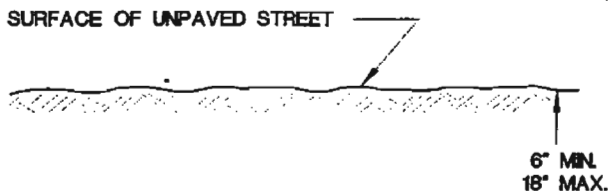

**SECTION A-A  
TYPE II-A  
UNPAVED STREET**

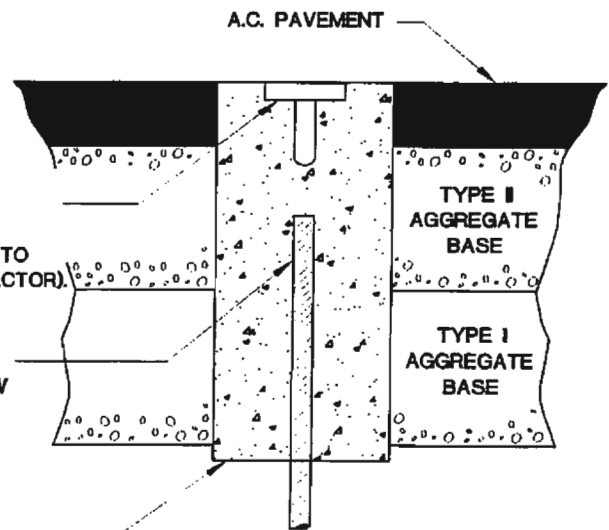

**SECTION A-A  
TYPE II-B  
PAVED STREET**

SPECIFICATION REFERENCE		UNIFORM STANDARD DRAWINGS CLARK COUNTY AREA		
501	CONCRETE	TYPE II MONUMENT		
621	MONUMENTS			
		DATE 12-14-00	DWG. NO. 240	PAGE NO. 46

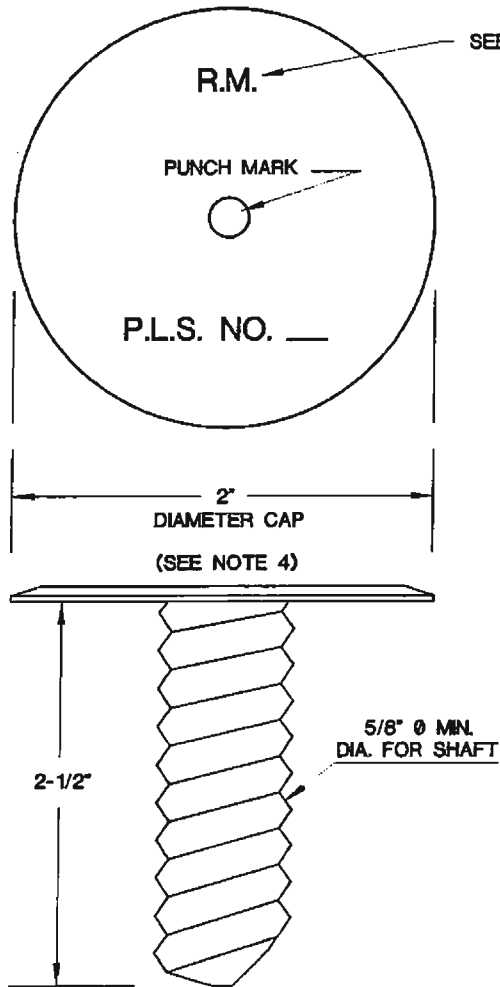

**DETAIL**  
STANDARD CAP

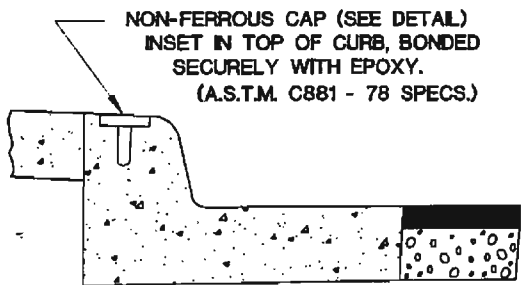

**TYPE IV-A MONUMENT**  
EXISTING CURB & GUTTER

**NOTES:**

1. FOUR (4) TYPE IV REFERENCE MONUMENTS TO BE SET WITHIN A RADIUS OF TWENTY (20) TO ONE HUNDRED (100) FEET FROM ALL TYPE I, II, AND III MONUMENTS.
2. THE TIE DISTANCE AND THE INITIALS R.M. ARE TO BE STAMPED ON THE CAP, FOR TYPE IV MONUMENTS.
3. NON-FERROUS CAP TO BE MADE FROM CAST VIRGIN METAL IN ONE PIECE, FREE FROM CASTING IMPERFECTIONS, WITH CORRUGATED SHAFT.
4. TYPE III AND TYPE IV MONUMENT CAP DIAMETER MAY BE REDUCED TO 1".

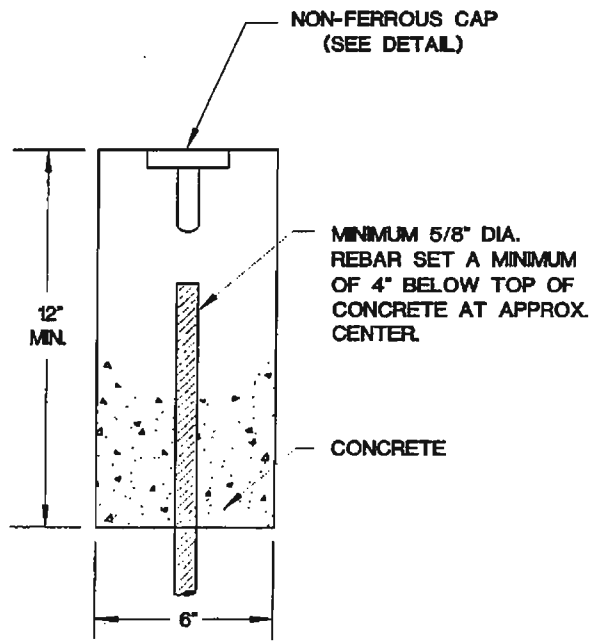

**TYPE IV-B MONUMENT**  
NO CURB & GUTTER

SPECIFICATION REFERENCE		UNIFORM STANDARD DRAWINGS CLARK COUNTY AREA		
501	CONCRETE	<b>TYPE IV MONUMENT</b>		
621	MONUMENTS			
		DATE 12-14-00	DWG. NO. 242	PAGE NO. 48

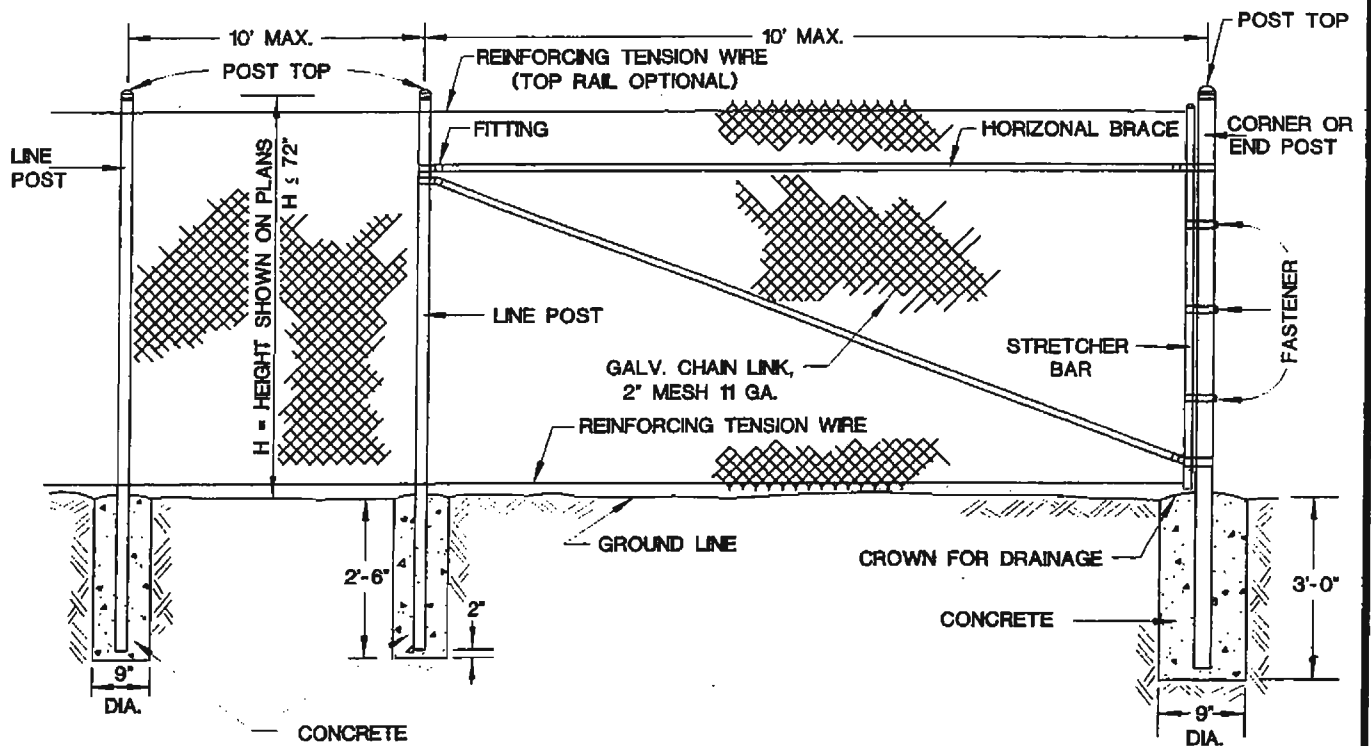

BARB WIRE (IF SPECIFIED)  
2 STRAND, 12 GA., 4 PT.

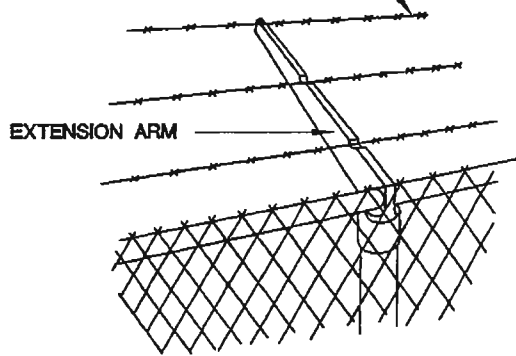

**EXTENSION ARM & BARBED WIRE**

**NOTES:**

1. FENCING SHALL BE CHAIN LINK AND SHALL CONSIST OF GALVANIZED CHAIN LINK FABRIC ON STEEL POSTS.
  - (A) ALL POSTS TOPS SHALL BE FITTED WITH SUITABLE FINALS.
  - (B) BRACES SHALL BE SPACED APPROXIMATELY 12" BELOW TOP OF TERMINAL POSTS AND SHALL EXTEND FROM END, GATE, OR CORNER POSTS TO FIRST ADJACENT LINE POST.
  - (C) ALL FITTINGS SHALL BE HOT-DIPPED GALVANIZED MALLEABLE, CAST IRON, OR PRESSED STEEL.
  - (D) TOP AND BOTTOM SELVAGES OF THE FENCE SHALL HAVE A TWISTED AND BARBED FINISH.
2. BARBED WIRE, EXTENSION ARMS, AND TOP HORIZONTAL RAILS SHALL BE INSTALLED ONLY WHEN SHOWN ON THE PLANS AND/OR CALLED FOR IN THE SPECIAL PROVISIONS.

**TABLE I**  
**FOR CHAIN LINK FENCE 72" AND LESS**

LOCATION	MIN. SIZE	MIN. WEIGHT
END, CORNER & PULL	2.351 O.D.	3.10
LINE	2.00 O.D.	2.72
BRACES	1.630 O.D.	2.27
TOP RAIL	1.630 O.D.	2.27

<b>SPECIFICATION REFERENCE</b>		<b>UNIFORM STANDARD DRAWINGS CLARK COUNTY AREA</b>	
501	CONCRETE	<b>CHAIN LINK FENCE (72" HIGH OR LESS)</b>	
616	FENCING		
DATE 12-14-00		DWG. NO. 252	PAGE NO. 58

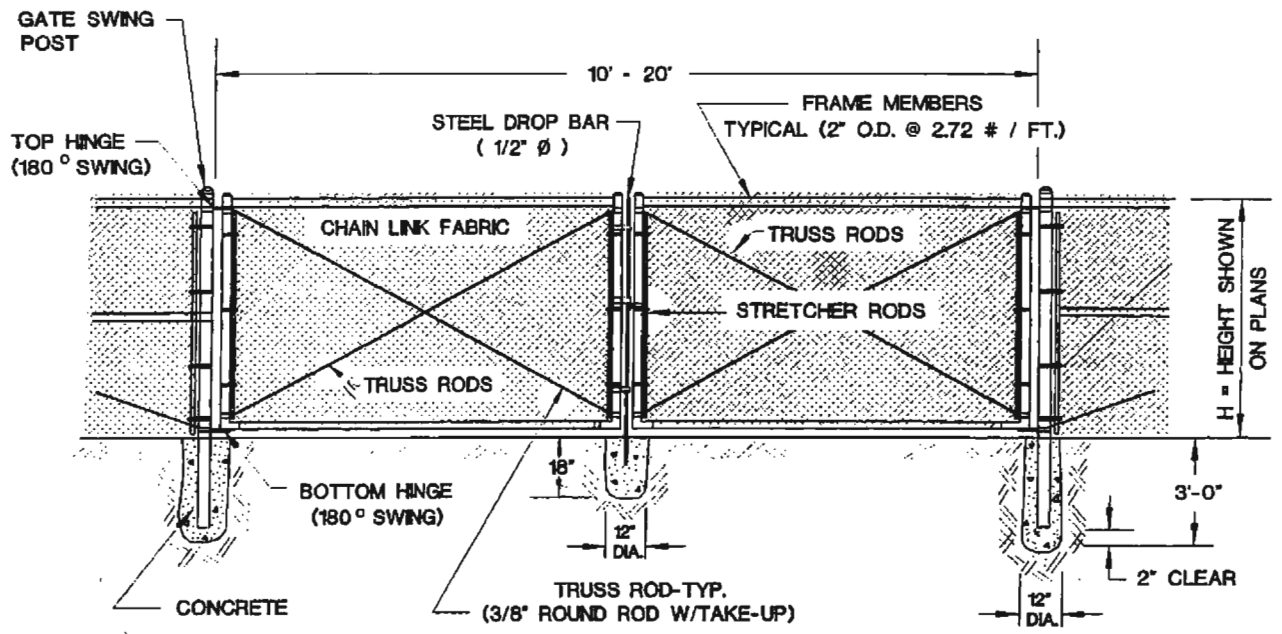

**DOUBLE SWING GATE**

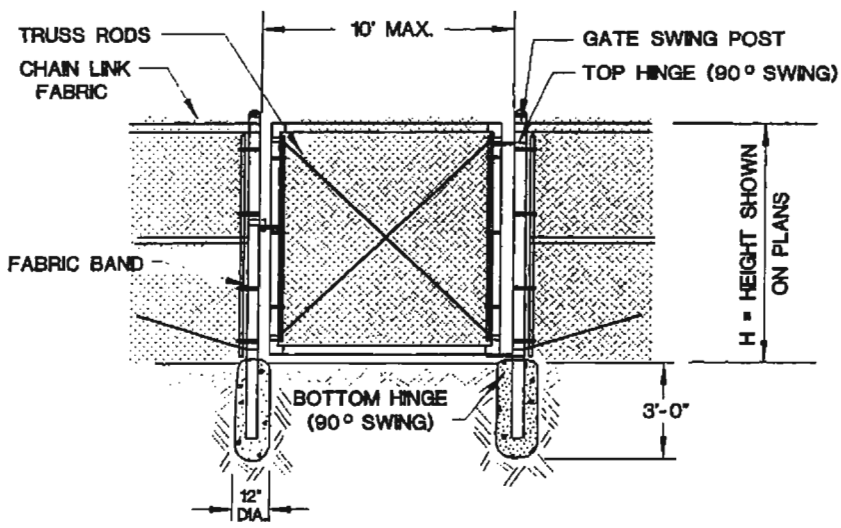

**SINGLE GATE**

GATE SWING POST DIA.	
GATE SIZE	PIPE DIA.
6' AND LESS	3\"O.D. - 5.79 LBS./FT.
6' - 10'	4\"O.D. - 9.10 LBS./FT.

SPECIFICATION REFERENCE		UNIFORM STANDARD DRAWINGS CLARK COUNTY AREA		
501	CONCRETE	CHAIN LINK GATES		
616	FENCING			
		DATE 12-14-00	DWG. NO. 253	PAGE NO. 59

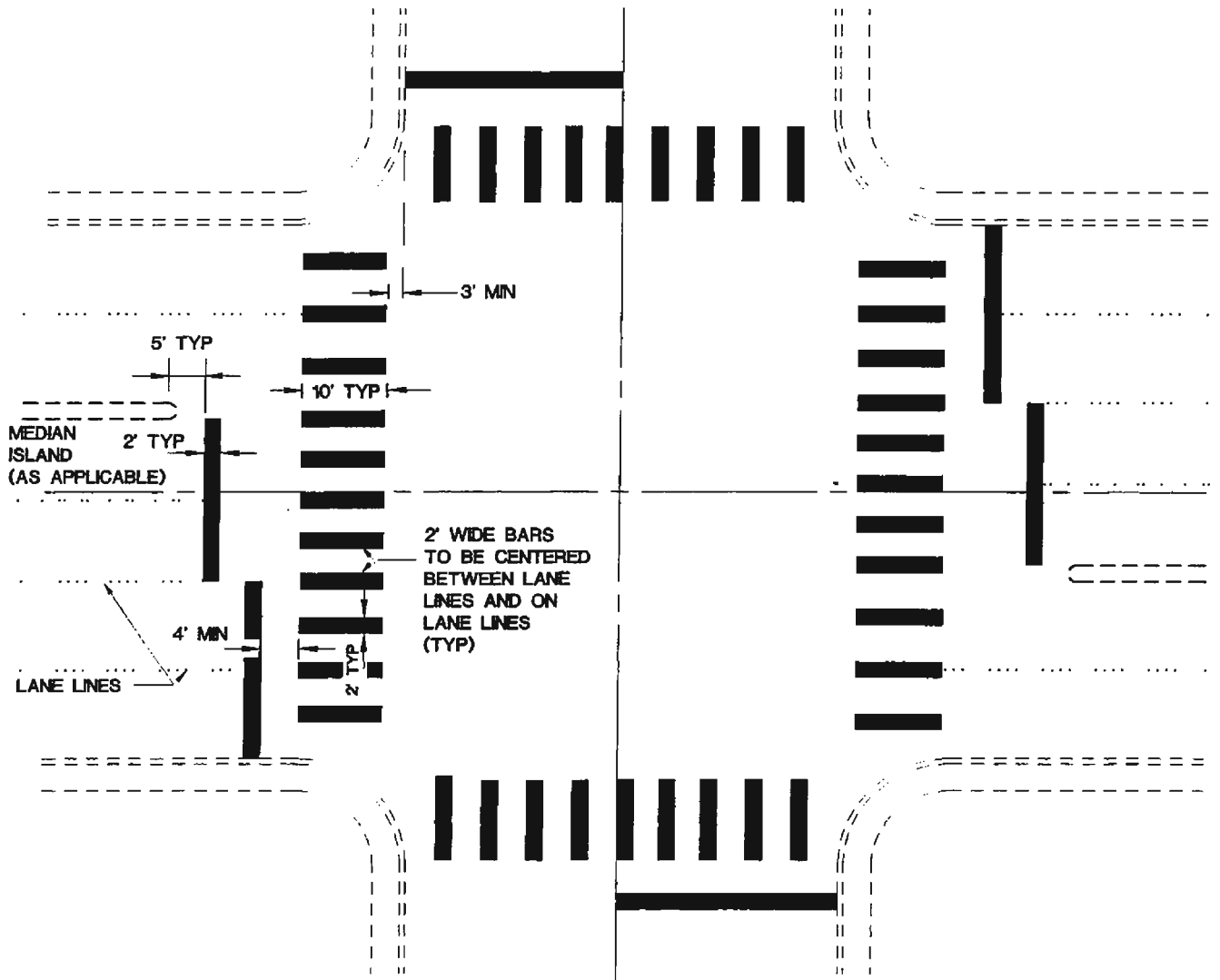

**TYPICAL CROSSWALK  
STRIPING DETAIL**

<b>SPECIFICATION REFERENCE</b>		<b>UNIFORM STANDARD DRAWINGS CLARK COUNTY AREA</b>	
		EXCEPT CITY OF LAS VEGAS	
		<b>CROSSWALK MARKINGS</b>	
		DATE 6-14-01	DWG. NO. 254A
		PAGE	59.1A

**NOTES:**

1. MANHOLE MATERIALS AND CONSTRUCTION SHALL CONFORM TO THE REQUIREMENTS OF SECTION 609, "CATCH BASINS, MANHOLES AND INLETS" OF THE "STANDARD SPECIFICATIONS".
2. REINFORCING STEEL SHALL BE AS SHOWN, WIRED TIGHTLY AT ALL INTERSECTIONS AND EMBEDDED AT LEAST ONE (1) INCH CLEAR UNLESS OTHERWISE NOTED.
3. EXCAVATION SHALL BE AS NEARLY VERTICAL AS POSSIBLE (SHEET AND SHORE, IF SOIL CONDITIONS REQUIRE), IN EXISTING STREET SECTIONS, ALLEY SECTIONS AND CONFINED AREAS SUCH AS LIMITED EASEMENTS OR ADJACENT TO STRUCTURES. NATURAL ANGLE OF REPOSE WILL ALLOW IN ALL OTHER AREAS.
4. MANHOLE DESIGN FOR PIPE LARGER THAN SIXTY (60) INCHES SHALL BE SUBMITTED TO THE ENGINEER FOR APPROVAL
5. MANHOLE DESIGN FOR DEPTHS EXCEEDING EIGHTEEN (18) FEET SHALL BE SUBMITTED TO THE ENGINEER FOR APPROVAL
6. TYPE AND SIZE OF MANHOLE TO BE CONSTRUCTED IN A PARTICULAR LOCATION SHALL BE DETERMINED BY THE PIPE SIZE, ALIGNMENT AND GRADE AS FOLLOWS:

**TYPE I**

**FORTY-EIGHT (48) INCH SIZE**

- A. ALL CASES FOR PIPE EIGHTEEN (18) INCHES AND SMALLER.
- B. TWENTY-FOUR (24) INCHES AND SMALLER PIPE ON TANGENT LINE AND GRADE.

**SIXTY (60) INCH SIZE**

- A. TWENTY-SEVEN (27) INCH THROUGH THIRTY-SIX (36) INCH PIPE ON TANGENT LINE AND GRADE.
- B. TWENTY-ONE (21) INCH THROUGH TWENTY-SEVEN (27) INCH PIPE AT ANGLE POINTS AND CHANGES IN GRADE OR PIPE SIZE.

**TYPE I-A**

USED IN PLACE OF TYPE I WHEN COVER ABOVE CONDUIT IS LIMITED, AND WHEN APPROVED BY THE ENGINEER.

**TYPE II**

**FORTY-EIGHT (48) INCH SIZE**

- A. THIRTY (30) INCH THROUGH SIXTY (60) INCH PIPE ON TANGENT LINE WITH A CHANGE IN GRADE OR PIPE SIZE.

<b>SPECIFICATION REFERENCE</b>		<b>UNIFORM STANDARD DRAWINGS CLARK COUNTY AREA</b>		
501	CONCRETE			
609	CATCH BASINS, MANHOLES & INLETS	<b>STORM DRAIN MANHOLES GENERAL NOTES</b>		
		DATE 12-14-00	DWG. NO. 401	PAGE 101

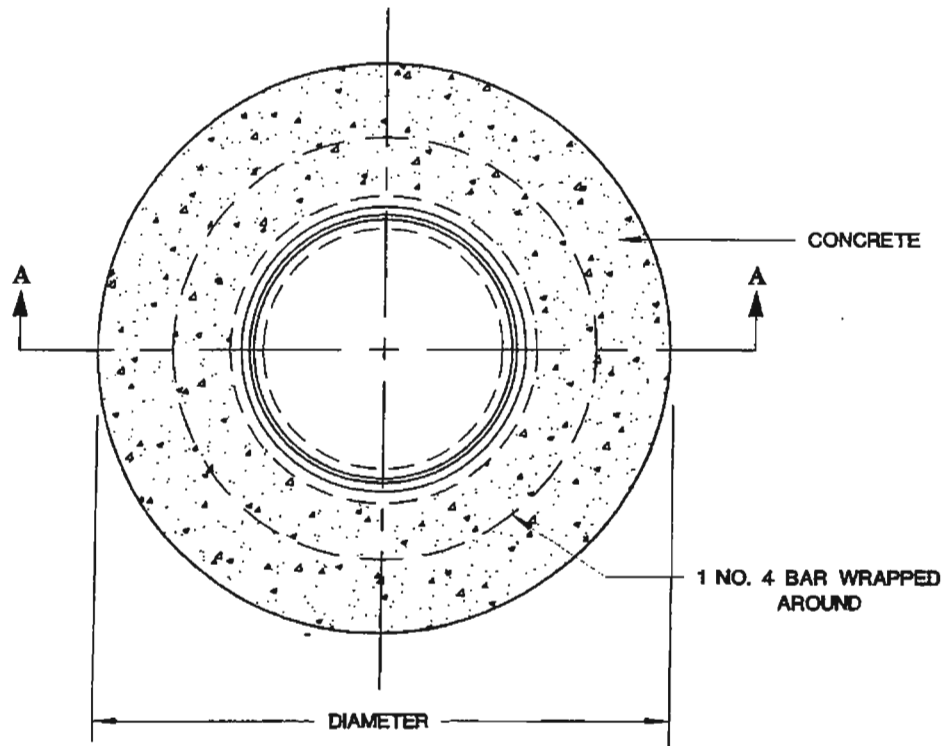

**PLAN**

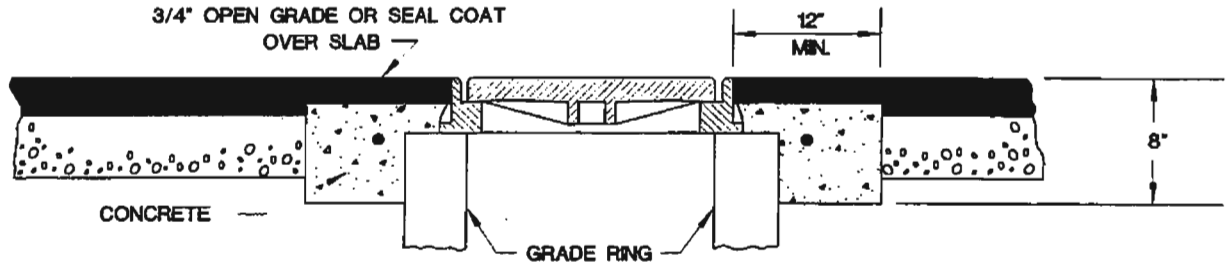

**SECTION A-A**

**NOTES:**

1. CONCRETE COLLAR TO BE CONSTRUCTED 1/8" BELOW SURFACE OF DENSE GRADE WHERE OPEN GRADE IS NOT USED.
2. CONCRETE COLLAR NOT REQUIRED IN UNINCORPORATED CLARK COUNTY RESIDENTIAL STREETS LESS THAN 80' R/W WIDTH.

<b>SPECIFICATION REFERENCE</b>		<b>UNIFORM STANDARD DRAWINGS CLARK COUNTY AREA</b>		
501	CONCRETE			
505	REINFORCING STEEL	<b>CONCRETE COLLAR AROUND MANHOLES</b>		
		DATE 12-14-00	DWG. NO. 408	PAGE NO. 108

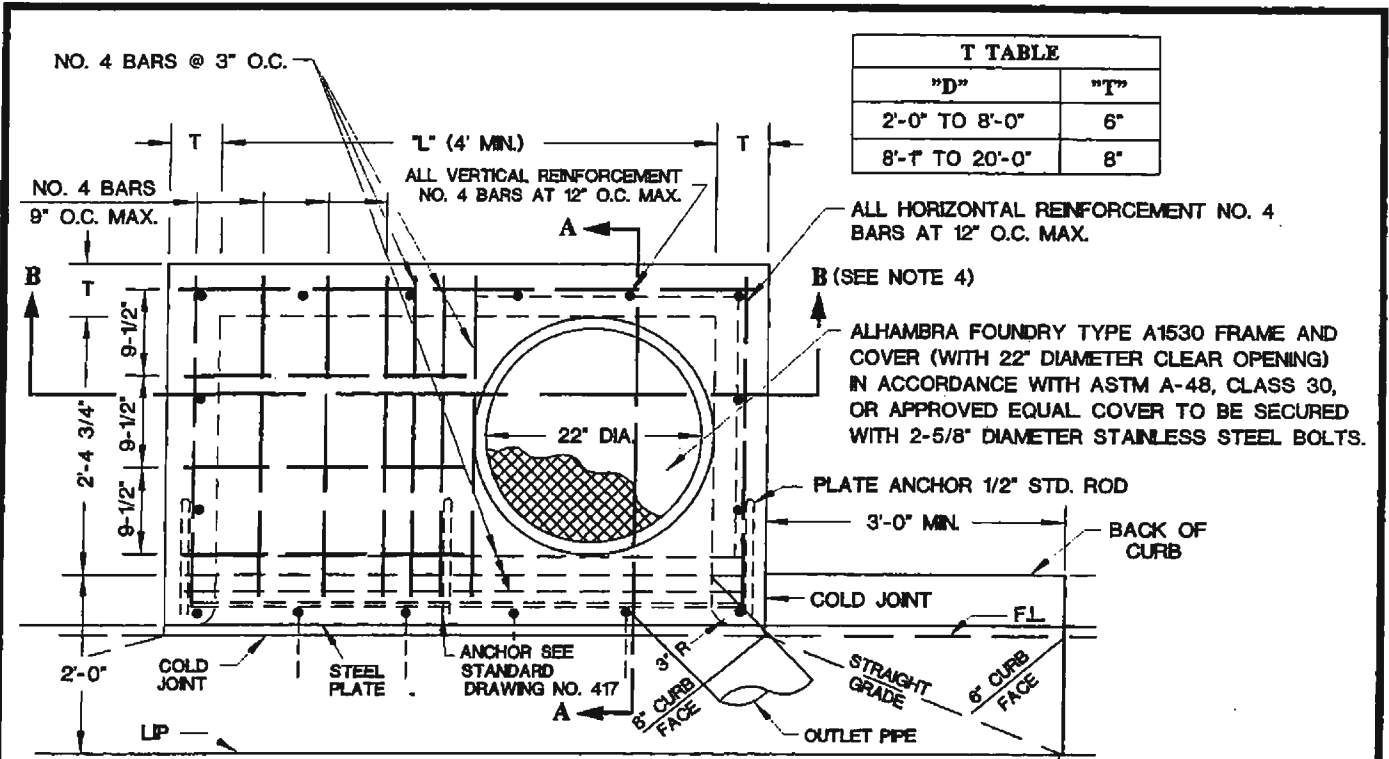

T TABLE	
"D"	"T"
2'-0" TO 8'-0"	6"
8'-1" TO 20'-0"	8"

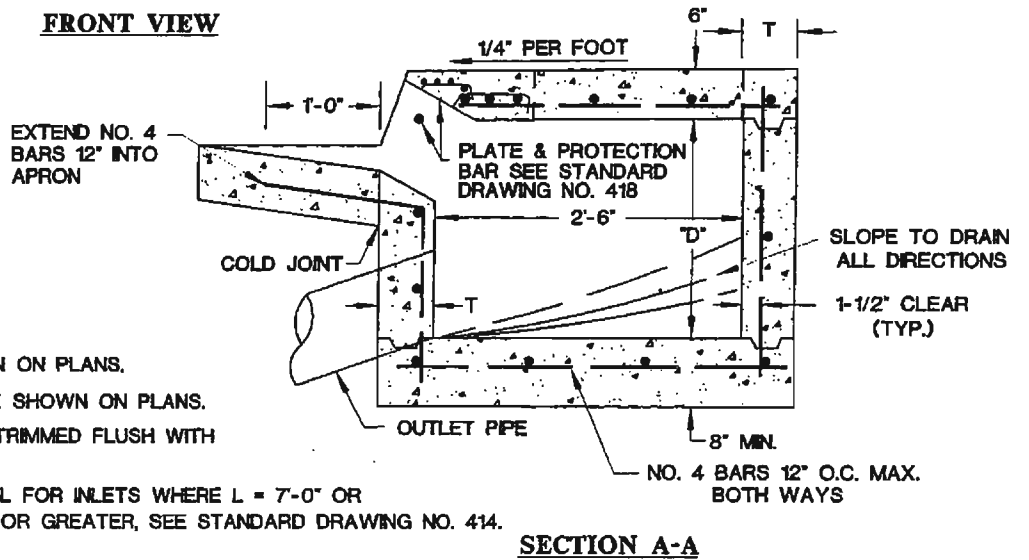
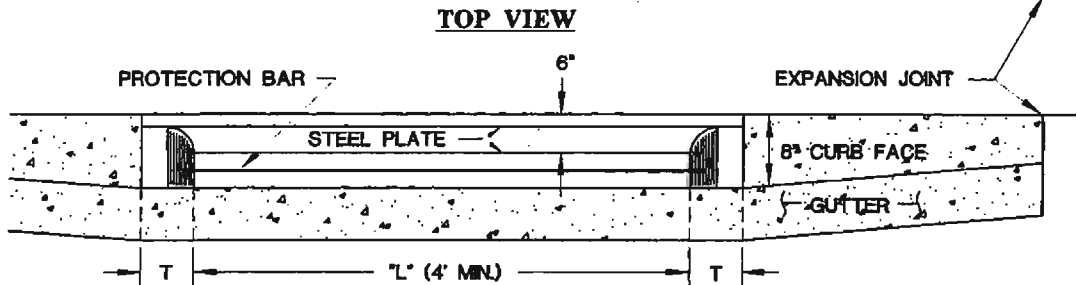

- NOTES:**
1. DEPTH "D" TO BE SHOWN ON PLANS.
  2. OUTLET PIPE SIZE TO BE SHOWN ON PLANS.
  3. OUTLET PIPE SHALL BE TRIMMED FLUSH WITH INSIDE FACE OF INLET.
  4. SECTION B-B IS OPTIONAL FOR INLETS WHERE L = 7'-0" OR GREATER, AND D = 5'-0" OR GREATER, SEE STANDARD DRAWING NO. 414.

SPECIFICATION REFERENCE	
501	CONCRETE
502	CONCRETE STRUCTURES
505	REINFORCING STEEL
713	STEEL

**UNIFORM STANDARD DRAWINGS  
CLARK COUNTY AREA**

**DROP INLET  
TYPE "A"**

DATE 12-14-00    DWG. NO. 411    PAGE NO. 111

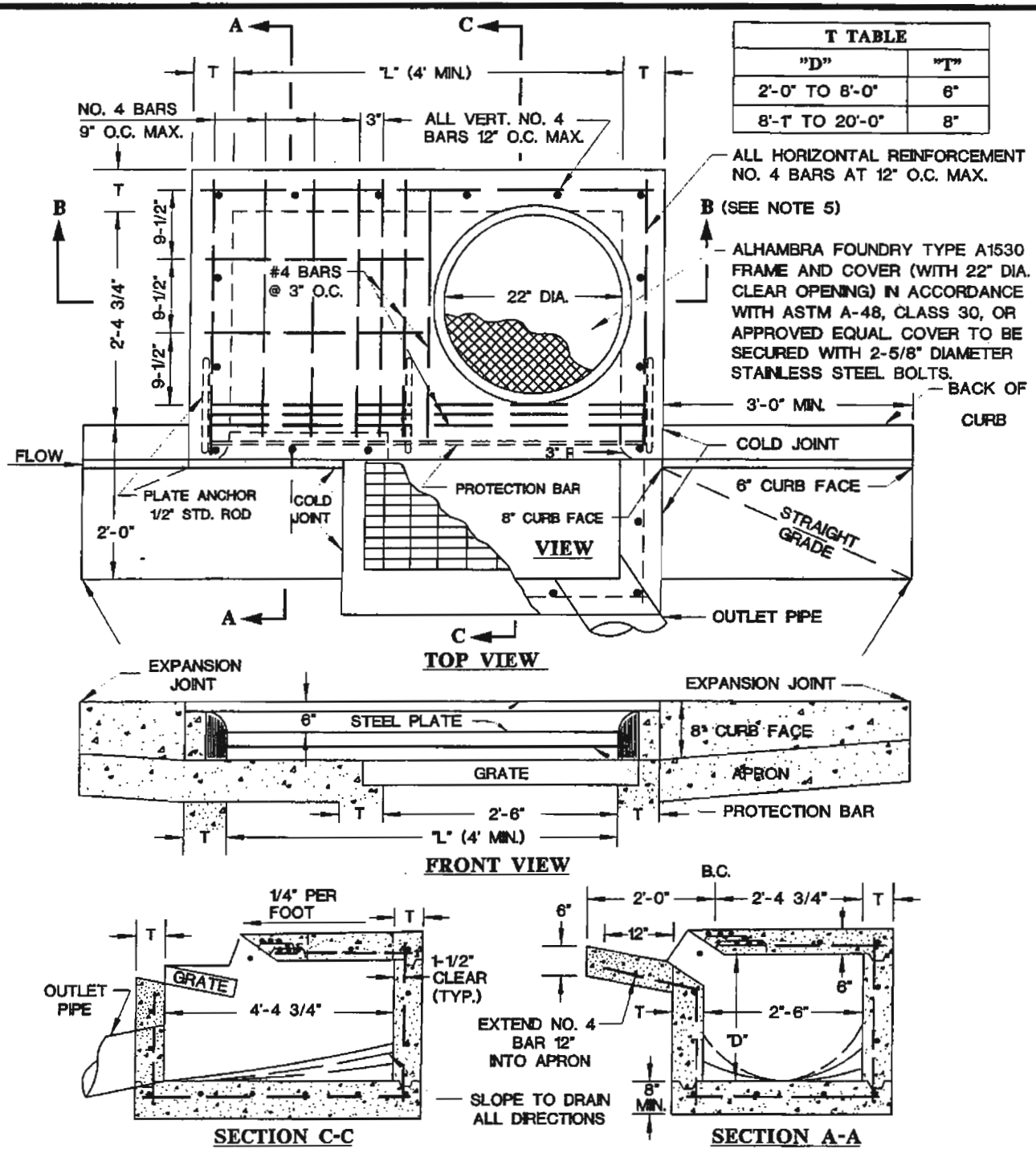

**NOTES:**

1. DEPTH 'D' TO BE SHOWN ON PLANS.
2. OUTLET PIPE SIZE TO BE SHOWN ON PLANS.
3. WHEN LENGTH 'L' EXCEEDS 4'-0" SUPPORT BOLTS REQUIRED, SEE STANDARD DRAWING NO. 418.
4. FOR GRATE DETAIL SEE STANDARD DRAWING NO. 416.
5. SECTION B-B IS OPTIONAL FOR INLETS WHERE L ≥ 7'-0" AND D ≥ 5'-0", SEE STANDARD DRAWING NO. 414.

SPECIFICATION REFERENCE		UNIFORM STANDARD DRAWINGS CLARK COUNTY AREA		
501	CONCRETE	DROP INLET TYPE "C"		
502	CONCRETE STRUCTURES			
505	REINFORCING STEEL			
713	STEEL			
		DATE 12-14-00	DWG. NO. 413	PAGE NO. 113

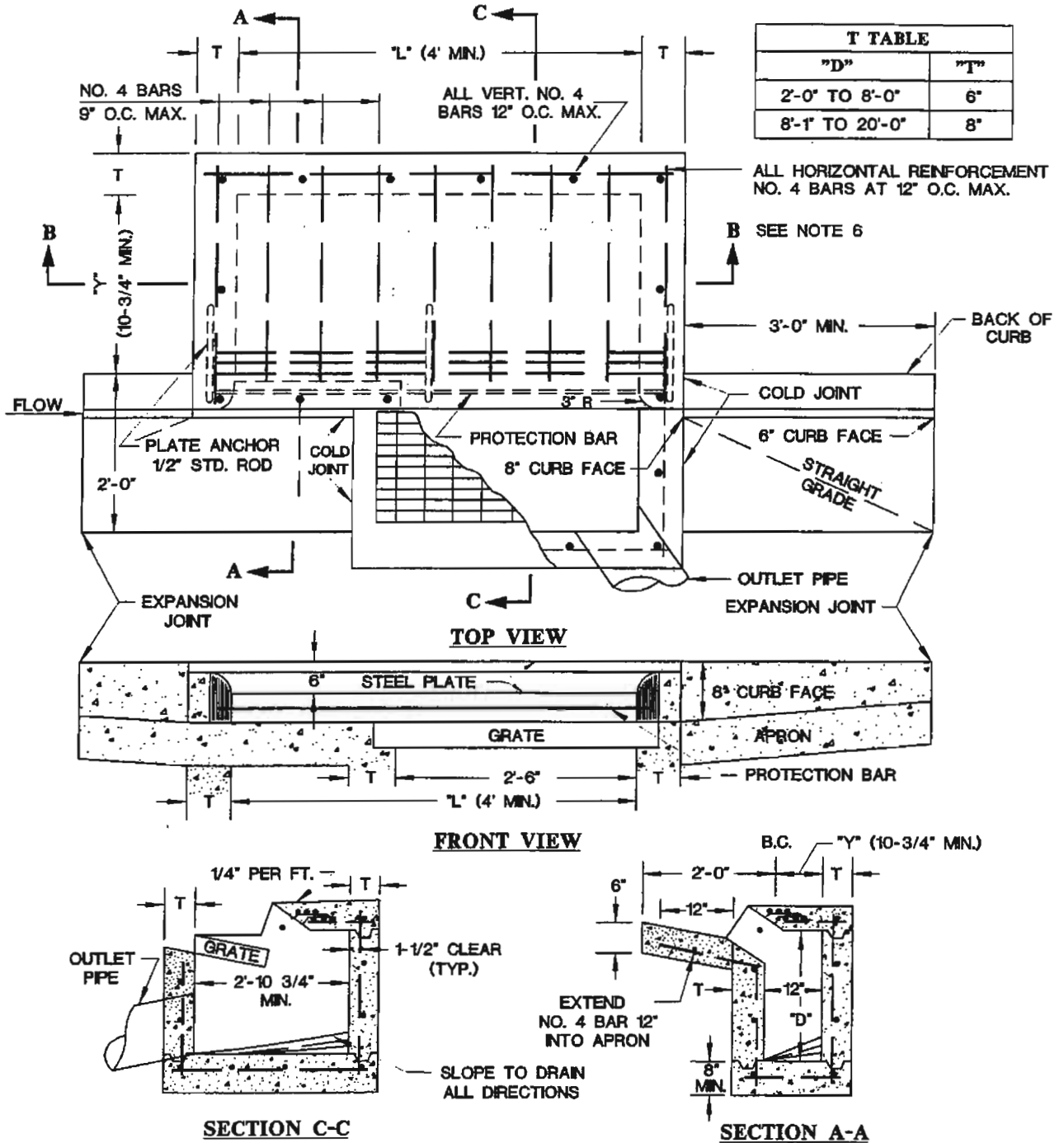

**NOTES:**

1. DROP INLET TYPE "D" TO BE USED WHEN CONFLICTING UTILITIES ARE LOCATED IN THE SIDEWALK AREA.
2. DEPTH "D" AND DISTANCE "Y" TO BE SHOWN ON PLANS.
3. OUTLET PIPE SIZE TO BE SHOWN ON PLANS.
4. WHEN LENGTH "L" EXCEEDS 4'-0" SUPPORT BOLTS REQUIRED, SEE STANDARD DRAWING NO. 418.
5. FOR GRATE DETAIL SEE STANDARD DRAWING NO. 416.
6. SECTION B-B IS OPTIONAL FOR INLETS WHERE L ≥ 7'-0" AND D ≥ 5'-0", SEE STANDARD DRAWING NO. 414.

SPECIFICATION REFERENCE		UNIFORM STANDARD DRAWINGS CLARK COUNTY AREA		
501	CONCRETE	DROP INLET TYPE "D"		
502	CONCRETE STRUCTURES			
505	REINFORCING STEEL			
713	STEEL			
		DATE 12-14-00	DWG. NO. 414	PAGE NO. 114

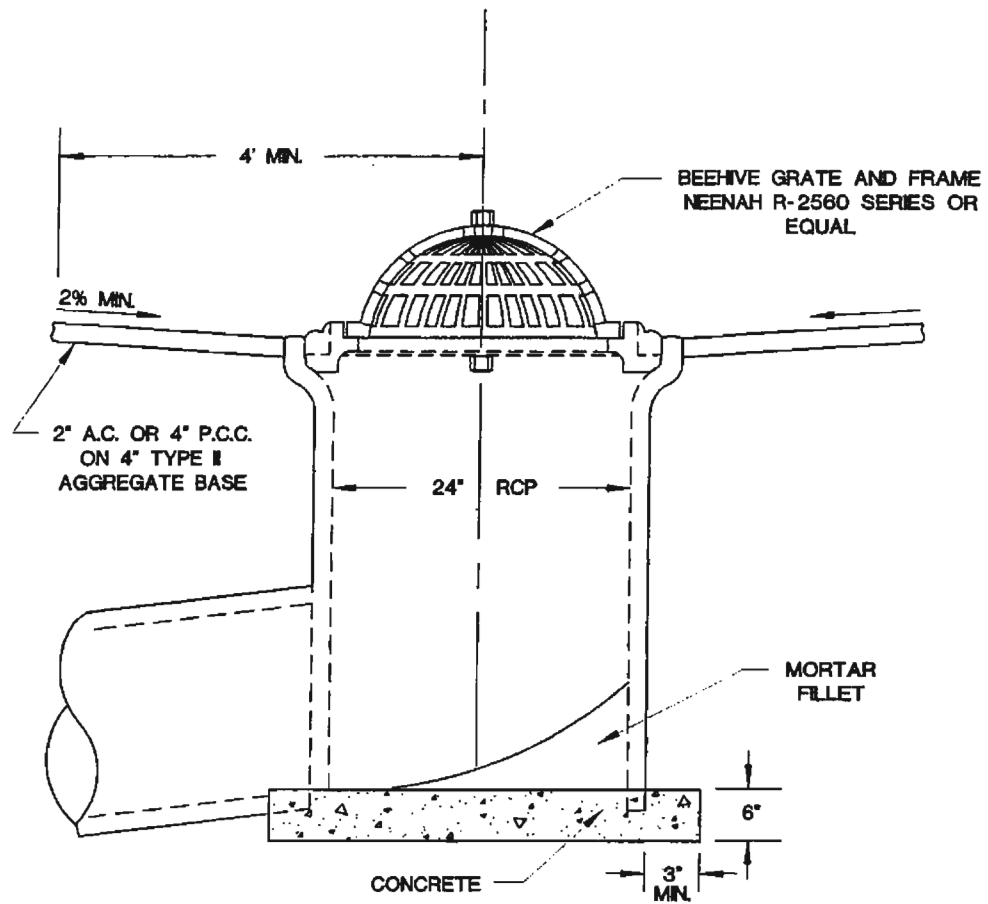

**NOTE:**

BEEHIVE DROP INLETS SHALL BE USED AT LOCATIONS APPROVED BY THE ENGINEER.

SPECIFICATION REFERENCE		UNIFORM STANDARD DRAWINGS CLARK COUNTY AREA		
603	REINFORCED CONCRETE PIPE			
712	MISCELLANEOUS METAL	BEEHIVE DROP INLET		
		DATE 12-14-00	DWG. NO. 416	PAGE NO. 116

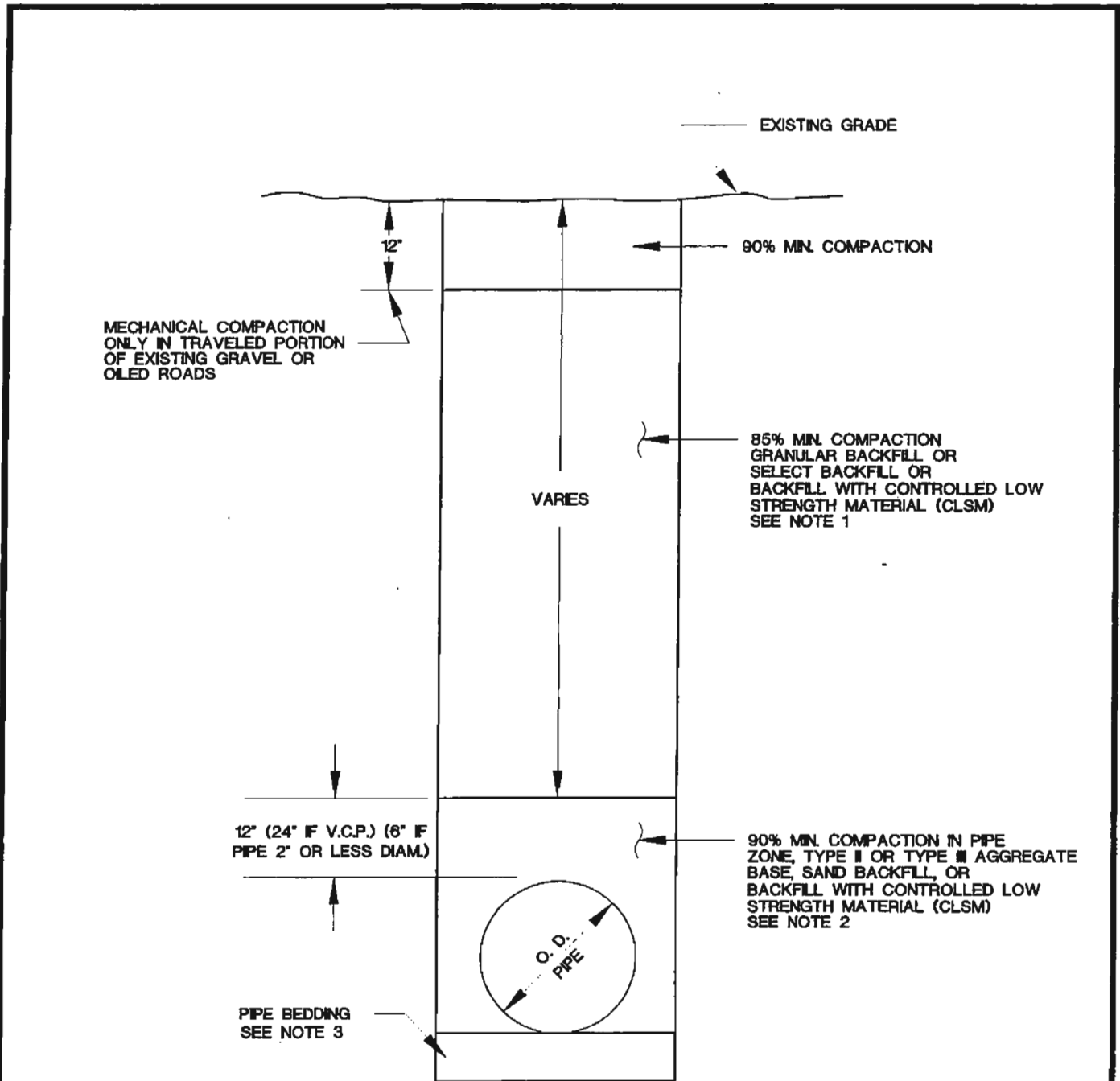

**NOTES:**

1. NO STONES OR LUMPS GREATER THAN 3" PERMITTED IN TRENCH 2' OR LESS IN WIDTH.
2. TRENCH WIDTH, BEDDING, AND PIPE ZONE REQUIREMENTS FOR UTILITY INSTALLATIONS SHALL CONFORM TO THE RESPECTIVE AGENCY REQUIREMENTS.
3. CRUSHED ROCK MAY BE USED FOR PIPE BEDDING ONLY IF MATERIAL USE HAS BEEN SPECIFICALLY APPROVED BY THE GOVERNING AGENCY. SEE STANDARD DRAWING NO. 505 FOR PIPE BEDDING METHODS.
4. LAS VEGAS VALLEY WATER DISTRICT REQUIRES PIPE BEDDING AND BACKFILL WITHIN THE PIPE ZONE TO BE OF THE SAME MATERIAL.

SPECIFICATION REFERENCE		UNIFORM STANDARD DRAWINGS CLARK COUNTY AREA		
208	TRENCH EXCAVATION & BACKFILL	TRENCH BACKFILL - UNPAVED AREAS AND AREAS OUTSIDE EXISTING OR FUTURE PROPOSED STREET RIGHT-OF-WAY		
302	AGGREGATE BASE COURSES			
		DATE 5-17-01	DWG. NO. 502	PAGE 122

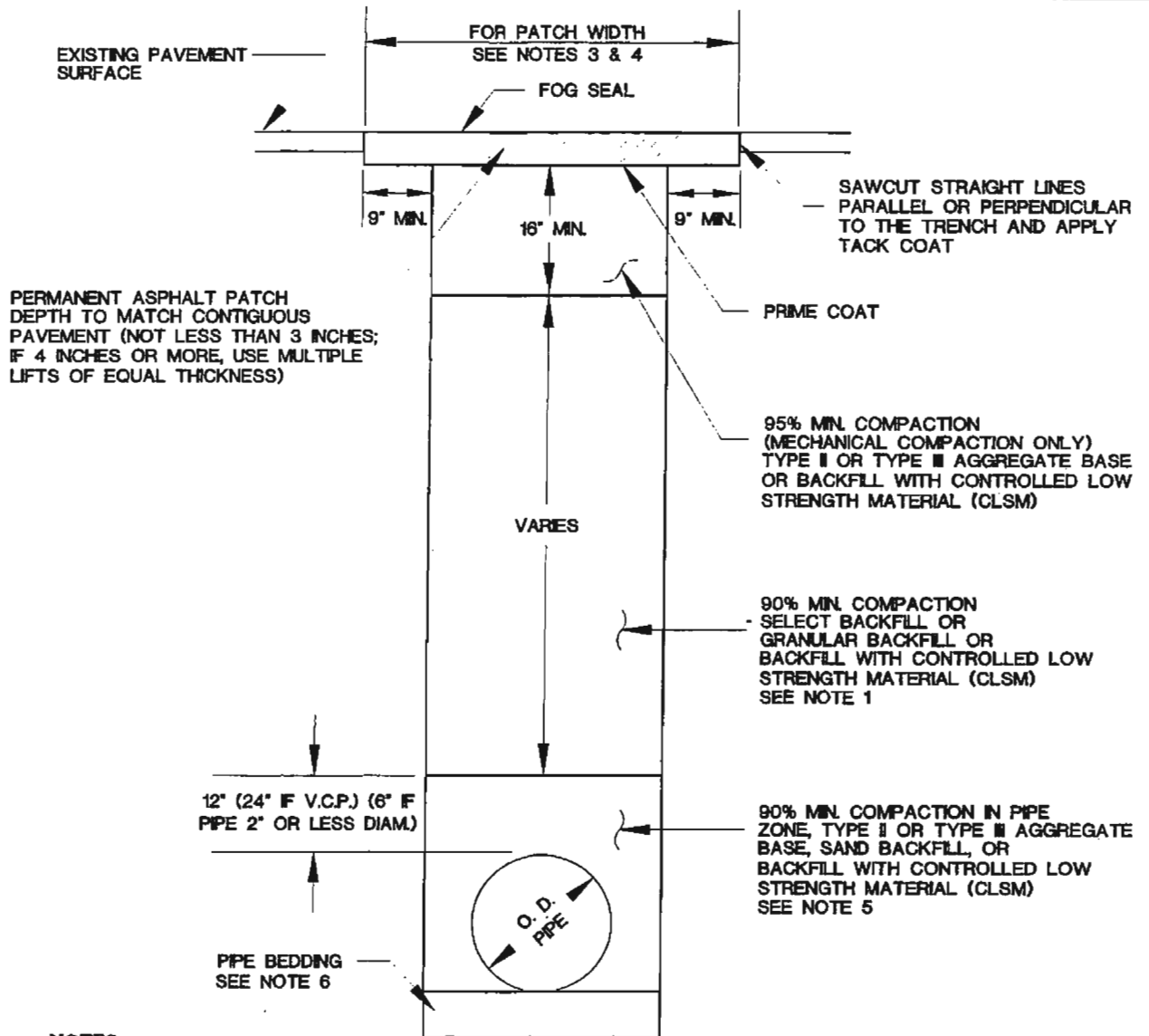

**NOTES:**

1. NO STONES OR LUMPS GREATER THAN 3" PERMITTED IN TRENCH 2' OR LESS IN WIDTH.
2. IF SAWCUT IS WITHIN THREE FEET OF EDGE OF EXISTING ASPHALT CONCRETE SURFACE OR OTHER PATCH, REMOVE EXISTING PAVEMENT TO THAT EDGE AND REPLACE ENTIRE SECTION.
3. PATCHES SHALL BE WIDTH (4 FEET MINIMUM) SUFFICIENT TO ACCOMMODATE MECHANICAL PLACEMENT USING AGENCY APPROVED SPREADER BOX OR PAVING MACHINE, ROLLING AND COMPACTION PER UNIFORM STANDARD SPECIFICATION SECTION 401.03.11. SAWCUTS SHALL NOT BE PLACED IN THE WHEEL PATH AREA.
4. FOR CONDUIT TRENCHES 6 INCHES WIDE OR LESS WITHIN 2 FEET OF THE CURB, PATCHES SHALL EXTEND A MINIMUM OF 4 FEET FROM LIP OF GUTTER AND PAVEMENT SHALL BE REMOVED TO CURB AND GUTTER; WIDTH SHALL BE SUFFICIENT TO ACCOMMODATE MECHANICAL PLACEMENT USING AGENCY APPROVED SPREADER BOX OR PAVING MACHINE, ROLLING AND COMPACTION PER UNIFORM STANDARD SPECIFICATION SECTION 401.03.11. SAWCUT SHALL NOT BE PLACED IN WHEEL PATH AREA.
5. TRENCH WIDTH, BEDDING, AND PIPE ZONE REQUIREMENTS FOR UTILITY INSTALLATIONS SHALL CONFORM TO THE RESPECTIVE AGENCY REQUIREMENTS.
6. CRUSHED ROCK MAY BE USED FOR PIPE BEDDING ONLY IF MATERIAL USE HAS BEEN SPECIFICALLY APPROVED BY THE GOVERNING AGENCY. SEE STANDARD DRAWING NO. 505 FOR PIPE BEDDING METHODS.
7. LAS VEGAS VALLEY WATER DISTRICT REQUIRES PIPE BEDDING AND BACKFILL WITHIN THE PIPE ZONE TO BE OF THE SAME MATERIAL.

SPECIFICATION REFERENCE		UNIFORM STANDARD DRAWINGS CLARK COUNTY AREA		
207	BACKFILL	<b>TRENCH BACKFILL PAVED AREAS (STREETS WITH 60' OR LESS R/W)</b>		
208	TRENCH EXCAVATION & BACKFILL			
302	AGGREGATE BASE COURSES			
401	BITUMINOUS PAVEMENT			
406	PRIME COAT			
407	FOG SEAL			
		DATE 5-17-01	DWG. NO. 503	PAGE 123

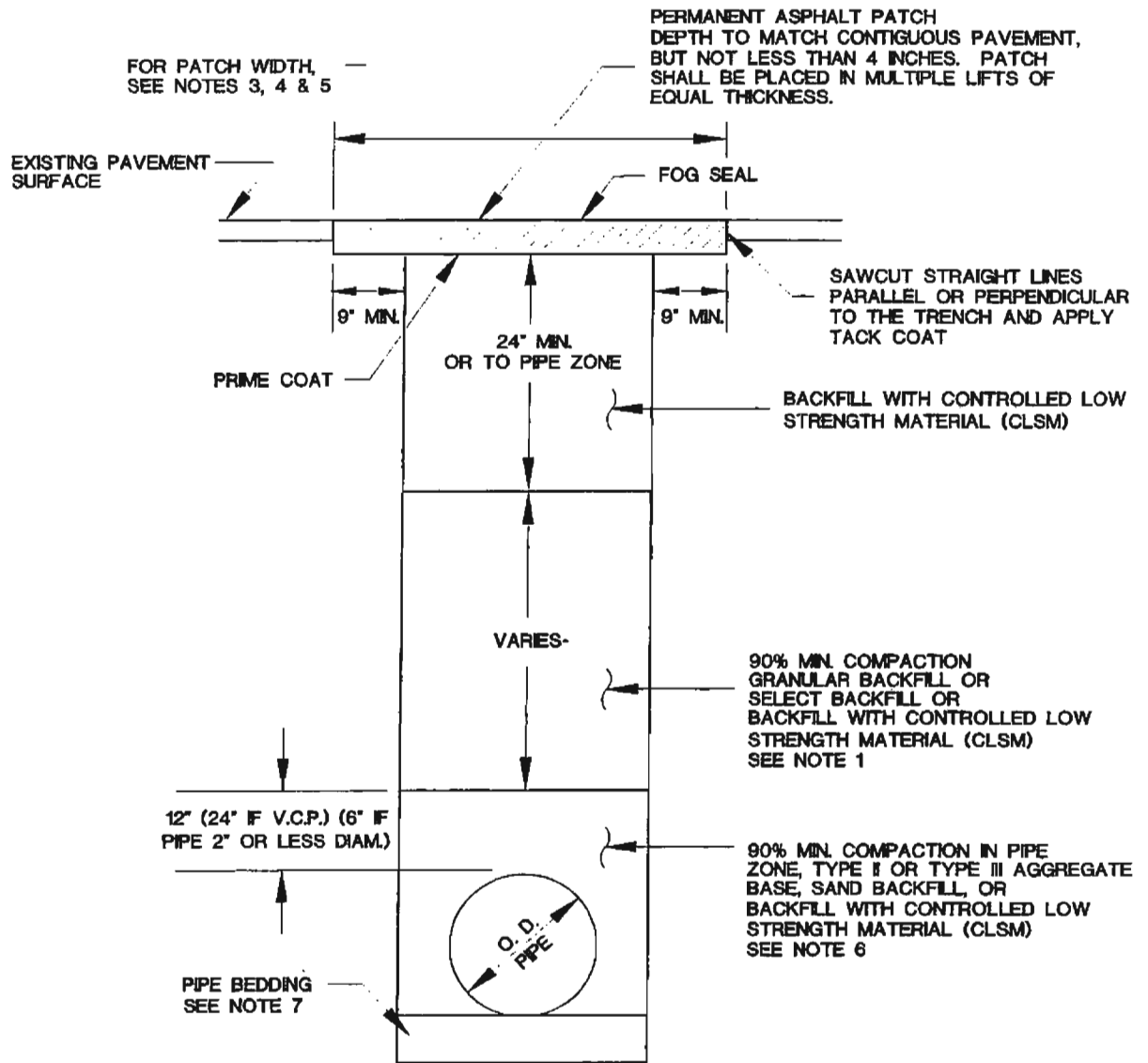

**NOTES:**

1. NO STONES OR LUMPS GREATER THAN 3" PERMITTED IN TRENCH 2' OR LESS IN WIDTH.
2. IF SAWCUT IS WITHIN THREE FEET OF EDGE OF EXISTING ASPHALT CONCRETE SURFACE OR OTHER PATCH, REMOVE EXISTING PAVEMENT TO THAT EDGE AND REPLACE ENTIRE SECTION.
3. TRANSVERSE PATCHES SHALL BE WIDTH (4 FEET MINIMUM) SUFFICIENT TO ACCOMMODATE MECHANICAL PLACEMENT, ROLLING AND COMPACTION PER UNIFORM STANDARD SPECIFICATION SECTION 401.03.11.
4. LONGITUDINAL PATCHES SHALL BE ONE TRAVEL LANE IN WIDTH; SAWCUTS ARE TO BE MADE AT THE EDGE OF THE TRAVEL LANE.
5. FOR CONDUIT TRENCHES 6 INCHES WIDE OR LESS WITHIN 2 FEET OF THE CURB, PATCHES SHALL EXTEND A MINIMUM OF 4 FEET FROM LIP OF GUTTER AND PAVEMENT SHALL BE REMOVED TO CURB AND GUTTER; WIDTH SHALL BE SUFFICIENT TO ACCOMMODATE MECHANICAL PLACEMENT USING AGENCY APPROVED SPREADER BOX OR PAVING MACHINE, ROLLING AND COMPACTION PER UNIFORM STANDARD SPECIFICATION SECTION 401.03.11. SAWCUT SHALL NOT BE PLACED IN WHEEL PATH AREA.
6. TRENCH WIDTH, BEDDING, AND PIPE ZONE REQUIREMENTS FOR UTILITY INSTALLATIONS SHALL CONFORM TO THE RESPECTIVE AGENCY REQUIREMENTS.
7. CRUSHED ROCK MAY BE USED FOR PIPE BEDDING ONLY IF MATERIAL USE HAS BEEN SPECIFICALLY APPROVED BY THE GOVERNING AGENCY. SEE STANDARD DRAWING NO. 505 FOR PIPE BEDDING METHODS.
8. LAS VEGAS VALLEY WATER DISTRICT REQUIRES PIPE BEDDING AND BACKFILL WITHIN THE PIPE ZONE TO BE OF THE SAME MATERIAL.

SPECIFICATION REFERENCE		UNIFORM STANDARD DRAWINGS CLARK COUNTY AREA		
207	BACKFILL	TRENCH BACKFILL WITH CONTROLLED LOW STRENGTH MATERIAL (CLSM) PAVED AREAS (STREETS GREATER THAN 60' R/W)		
208	TRENCH EXCAVATION & BACKFILL			
302	AGGREGATE BASE COURSES			
401	BITUMINOUS PAVEMENT			
406	PRIME COAT			
407	FOG SEAL	DATE 5-17-01	DWG. NO. 504	PAGE 124

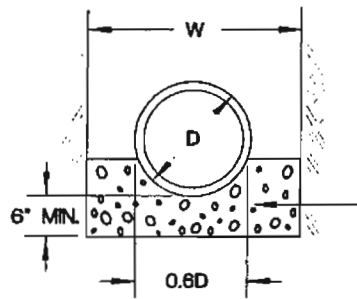

SHAPED GRANULAR FOUNDATION

TYPE II OR TYPE III  
AGGREGATE BASE  
OR SAND BACKFILL  
SEE NOTE 4

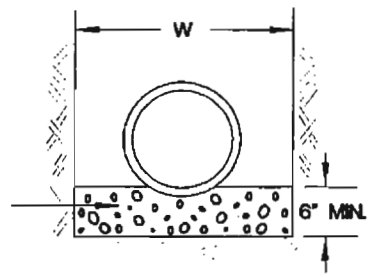

FLAT GRANULAR FOUNDATION

**CLASS B BEDDING (NORMAL BEDDING)**

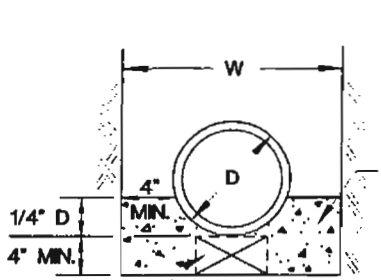

— BRICK OR CONCRETE BLOCK

CONCRETE CRADLE

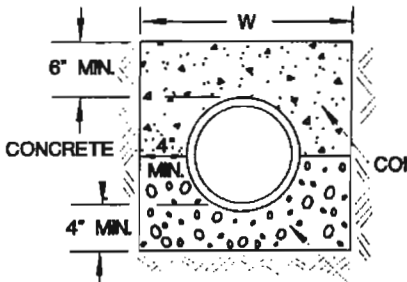

TYPE II OR TYPE III  
AGGREGATE BASE OR BACKFILL

CONCRETE CAP

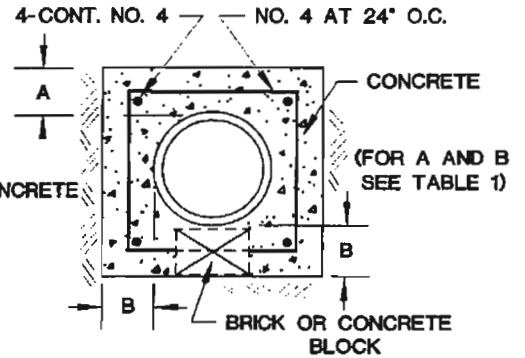

CONCRETE ENCASEMENT

**CLASS A BEDDING (CONCRETE BEDDING)**

PIPE SIZE	PIPE		PIPE SIZE	PIPE	
	B	A		B	A
6"	4"	4"	24"	6"	6"
8"	4"	4"	27"	7"	6"
10"	4"	4"	30"	8"	6"
12"	4"	4"	33"	8"	6"
15"	4"	4"	36"	9"	6"
18"	5"	5"	39"	9"	6"
21"	5"	5"	42"	10"	6"

D = OUTSIDE DIAMETER OF PIPE  
W = OUTSIDE DIAMETER OF PIPE + 24" MAXIMUM

**NOTES:**

1. PIPE BEDDING TO BE COMPACTED TO AT LEAST 90% OF MAXIMUM DENSITY.
2. INDICATED THICKNESS OF BEDDING MATERIAL TO BE CONSTRUCTED UNDER THE BARREL. SUBGRADE TO BE EXCAVATED TO PROVIDE 2" CLEARANCE UNDER THE BELL.
3. OTHER BEDDING METHODS MAY BE SPECIFIED OR APPROVED.
4. CRUSHED ROCK MAY BE USED FOR PIPE BEDDING ONLY IF MATERIAL USE HAS BEEN SPECIFICALLY APPROVED BY THE GOVERNING AGENCY.

SPECIFICATION REFERENCE		UNIFORM STANDARD DRAWINGS CLARK COUNTY AREA		
208	TRENCH EXCAVATION & BACKFILL	PIPE TRENCH BEDDING METHODS		
302	AGGEGATE BASE COURSES			
501	CONCRETE			
505	REINFORCEMENT STEEL			
		DATE 5-17-01	DWG. NO. 505	PAGE NO. 125

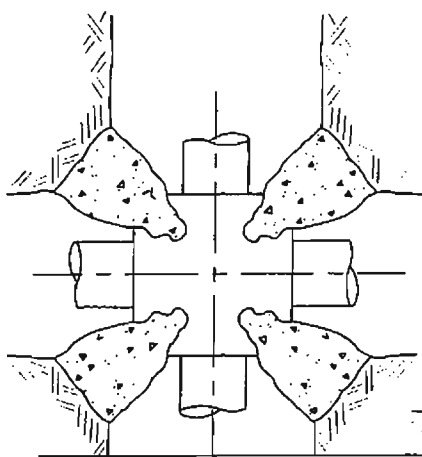

**CROSS**  
**FIG.1**

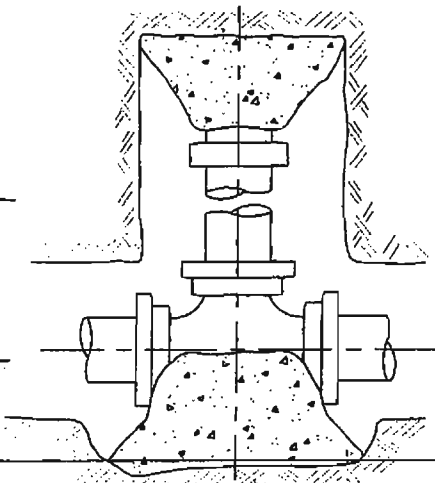

**TEE OR PLUG**  
**FIG.2**

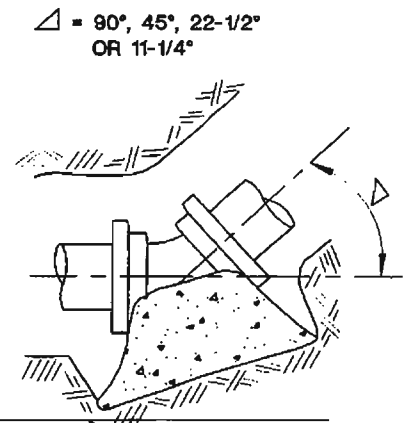

**HORIZONTAL OR VERTICAL ELBOW**

NO. 5  
REBAR  
STRAP

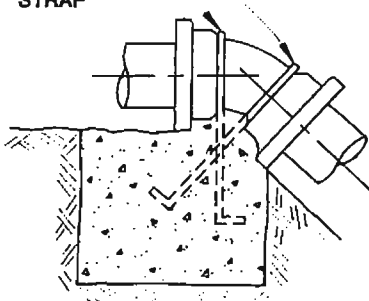

**ELBOW**  
**FIG.4**

**NOTES:**

1. ALL FITTINGS AND EXPOSED REBAR TO BE COATED WITH EC 244 AND WRAPPED WITH TWO LAYERS OF 6 MIL. POLYETHYLENE.
2. TABLE BELOW DENOTES MINIMUM BEARING AREA OR VOLUME OF THRUST BLOCK. SPECIAL DESIGN FOR EACH INSTALLATION IS REQUIRED IF ALLOWABLE SOIL BEARING CAPACITY IS LESS THAN 3000 P.S.F.
3. PLACE CONCRETE AGAINST UNDISTURBED EARTH.
4. VERTICAL SURFACES NOT BEARING AGAINST UNDISTURBED EARTH SHALL BE FORMED.

SIZE OF PIPE	MINIMUM BEARING AREA IN SQUARE FEET						CUBIC YARDS OF CONCRETE		
	FIG. 1	FIG. 2	FIG. 3				FIG. 4		
			90°	45°	22-1/2°	11-1/4°	45°	22-1/2°	11-1/4°
4"		2	2	1	1	1	1.0	.5	.5
6"	2	3	3	2	1	1	1.5	1.0	.5
8"	2	5	6	3	2	1	2.0	1.0	.5
10"	3	7	10	5	3	1	4.0	2.0	1.0
12"	3	10	14	8	4	2			
14"	4	14	20	10	5	3			
16"	4	20	24	12	7	4			
18"	5	24	30	16	10	5			
20"	5	28	40	20	12	6			

SPECIAL  
DESIGN

SPECIFICATION REFERENCE	

UNIFORM STANDARD DRAWINGS CLARK COUNTY AREA			
THRUST BLOCK DETAILS			
DATE 12-14-00	DWG. NO.	512	PAGE NO. 132

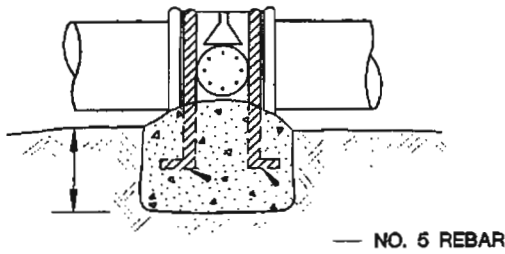

**ELEVATION - B.F. VALVE**

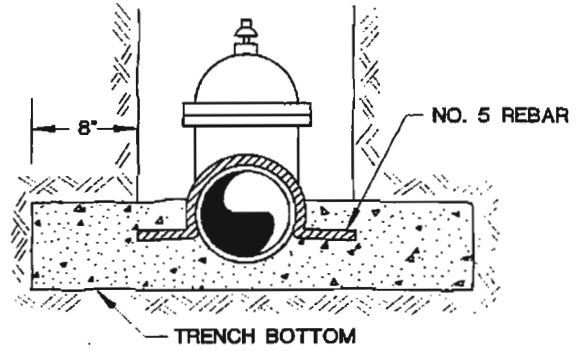

**ELEVATION  
REDUCER OR GATE VALVE**

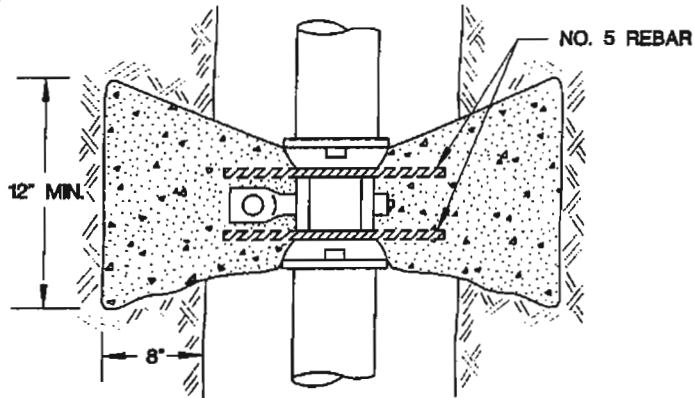

**PLAN - RING-TITE  
B.F. VALVE**

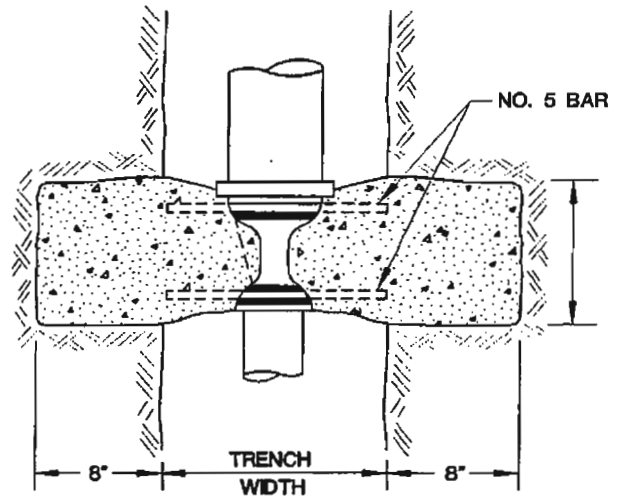

**PLAN  
REDUCER OR  
GATE VALVE**

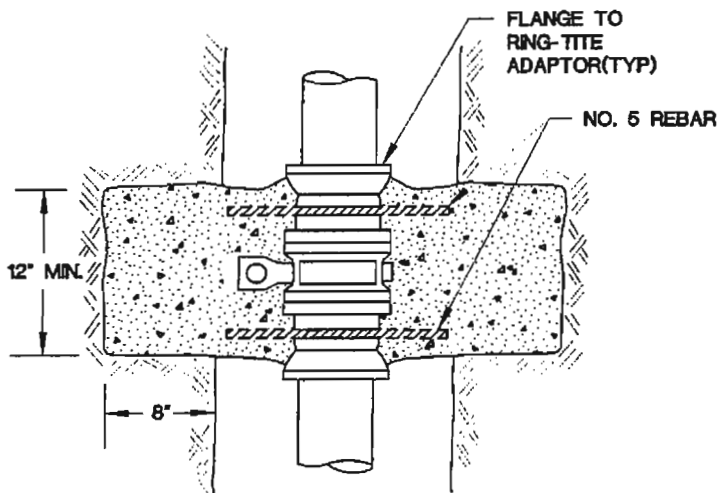

**PLAN - FLANGE MT. B.F. VALVE**

**NOTES:**

1. ALL VALVES TO BE PAINTED WITH E.C. 244 AND WRAPPED WITH TWO LAYERS OF 6 MIL POLYETHYLENE.

<b>SPECIFICATION REFERENCE</b>	<b>UNIFORM STANDARD DRAWINGS CLARK COUNTY AREA</b>		
	<b>ANCHOR BLOCK DETAILS REDUCER OR VALVE</b>		
	DATE 12-14-00	DWG. NO. 513	PAGE NO. 133





**PAVED STREET INSTALLATION**

**UNPAVED STREET INSTALLATION**

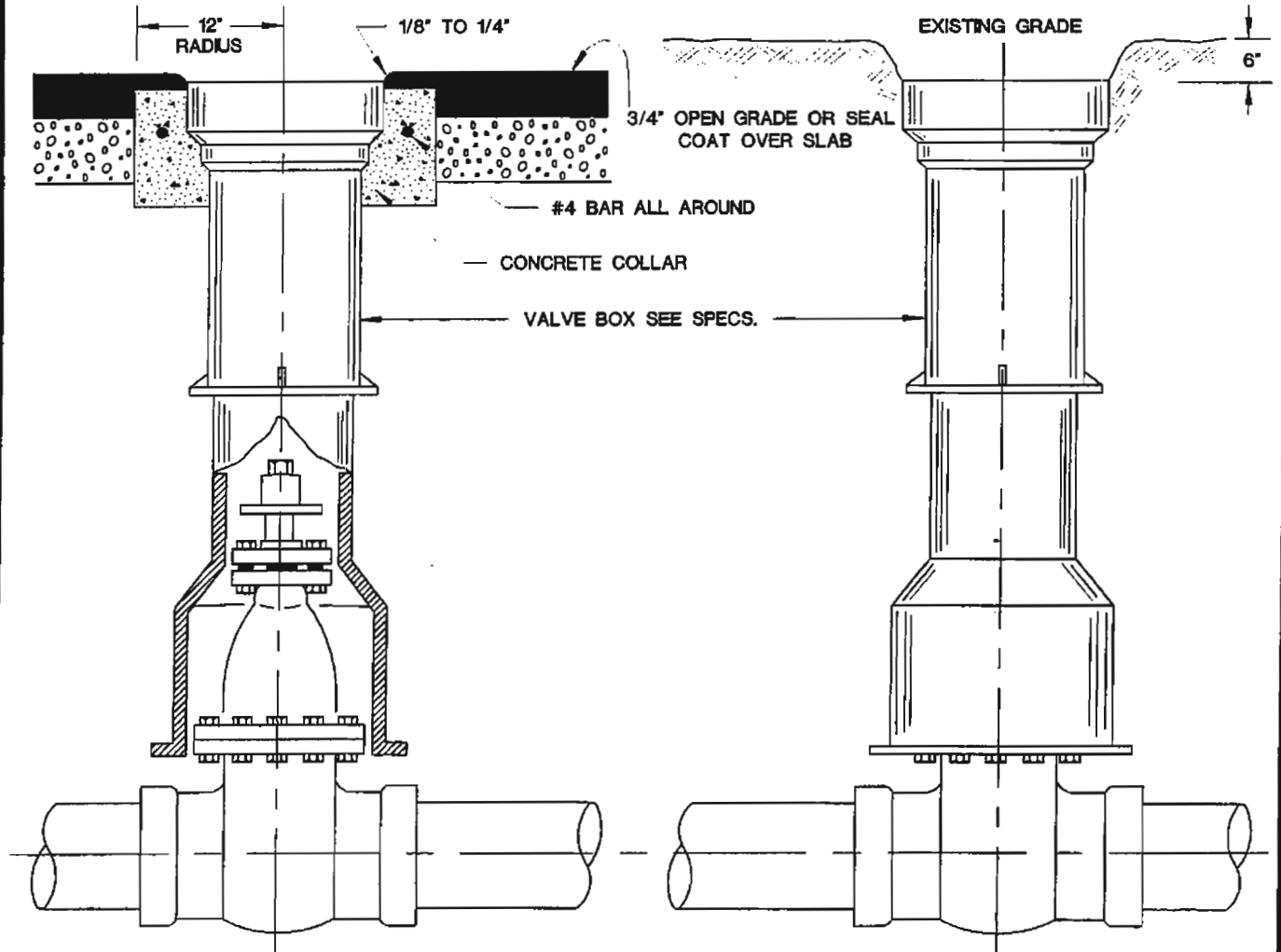

**ADJUSTMENT**

RAISE TOP SECTION AND/OR INSTALL RISERS AS NECESSARY. TYLER OR APPROVED EQUAL.

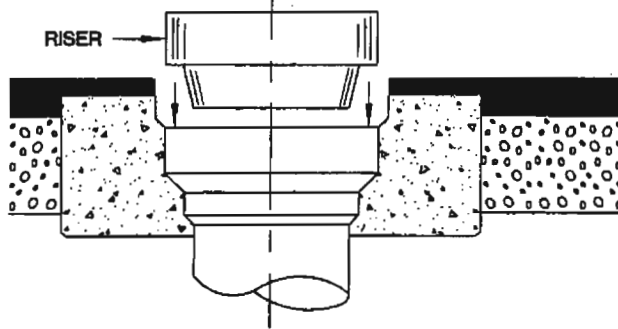

**NOTE:**

CONCRETE COLLAR NOT REQUIRED IN UNINCORPORATED CLARK COUNTY RESIDENTIAL STREETS LESS THAN 80' R/W.

SPECIFICATION REFERENCE		UNIFORM STANDARD DRAWINGS CLARK COUNTY AREA		
		VALVE BOX INSTALLATION & ADJUSTMENT		
		DATE 12-14-00	DWG. NO. 517	PAGE NO. 137