

**UNIFORM STANDARD DRAWINGS
CLARK COUNTY AREA
VOLUME I**

**REVISION SET I
1995**

<u>DRAWING NUMBER AND TITLE</u>	<u>PAGE NUMBER(S)</u>	<u>NATURE OF CHANGE</u>	<u>APPROVAL DATE</u>
217 Roll Type Curb and Gutter Residential Area	23	Editorial Changes; Clark County Only	9/13/90
217A 30" Roll Curb Residential Area	23A	New Drawing; applies to Las Vegas and North Las Vegas	9/13/90
235 Sidewalk Ramp (4 Sheets)	41 - 41C	Changes to conform to ADA	8/13/92
254 Crosswalk Markings	59A	New Drawing to conform to ADA	8/13/92
222 Residential Driveway Geometrics	28	Changed to a standard for residential only; additional editorial changes.	11/12/92
222A Commercial and Multi-family Driveway Geometrics	28A	New drawing; addresses commercial curb return driveways	11/12/92
225 Commercial and Industrial Driveway (Option B) or Private Street Access	31	Revised to meet new commercial driveway standard; Added driveway/street cross section.	2/11/93
322 Base Adaptor Plate for 16-1/2" Bolt Circle Foundation	81	Revised to be consistent with Volume II.	2/11/93
323 Base Adaptor Plate for 19" Bolt Circle Foundation	82	Revised to be consistent with Volume II.	2/11/93
244 Typical Centerline Delineation	50	Type 2 centerline pavement markers moved.	6/11/93
244A Typical Lane Line Delineation	50A	New Drawing; lane lines for divided, one-way or undivided roadways.	"

DRAWING NUMBER AND TITLE	PAGE NUMBER(S)	NATURE OF CHANGE	APPROVAL DATE
245 Typical Lane Delineation Transition Sections (1 of 3)	51	Revised to conform to new striping standards; removed gore detail; revised dimensions.	6/11/93
245 Details for Typical Lane Delineation in Transitions Sections (2 of 3)	51A	Gore detail for Sheet 1; new gore detail added to address other end of transitions; striping revised.	"
245 Typical Lane Delineation in Transition Sections where Traffic Flow in Same Direction (3 of 3)	51B	New Drawing; gore for separating traffic in the same direction. Paint, tape or pavement marker options.	"
246 Standard Pavement Markers Added Turn Lane	52	Revised to added left and right turn lanes and typ. median requirements.	"
246A Standard Pavement Markers Forced Turn Lane	52A	New Drawing; forced left and right turn lane requirements.	"
247 Marker Details and Lane Marker Schedule	53	Changed Type F symbol; deleted octagonal reflector.	"
248 Median Nose Markings	54	Added reflective paint to median; delete octagonal reflector references.	"
246 Standard Pavement Markers Added Turn Lane	52	Optional marking following return radius for additional guidance.	8/11/93
246A Standard Pavement Markers Forced Turn Lane	52A	"	"
217A 30" Roll Curb Residential Area	23A	Added flowline gradient restriction for North Las Vegas.	1/13/94
222 Residential Driveway Geometrics	28	Added property line setback restriction for North Las Vegas	"
201.1 Additional Right-of-Way Required at Major Intersections	7.1	New Drawing; minimum right-of- way requirements for dual left and exclusive right turn lanes.	6/9/94
234.1 Typical Bus Turn-out	40.1	New Drawing.	"

DRAWING NUMBER AND TITLE	PAGE NUMBER(S)	NATURE OF CHANGE	APPROVAL DATE
234.2 Bus Stop Loading Pad and Optional Sidewalk Ramp	40.2	New Drawing.	6/9/94
235 Sidewalk Ramp Case IV	41C	New Drawing; referenced by Drawing No. 234.2.	"
245.1 Typical Lane Configuration for Major Street Intersections and Median Detail Case I	51.1	New Drawing; shows typical lane configuration for dual left and optional exclusive right turn lanes and 605 ft. median.	"
245.1 Typical Lane Configuration for Major Street Intersections and Median Detail Case II	51.1A	New Drawing; shows typical lane configuration for dual left and optional exclusive right turn lanes and 300 ft. median.	"
244.1 Typical Delineation for Bike Facilities 100 Ft. or Greater Right-of-way	50.1	New Drawing incorporated from the Bicycle/Pedestrian Element of the Regional Transportation Plan.	6/8/95
244.1A Typical Delineation for Bike Facilities 100 Ft. Right-of-way	50.1A	"	"
244.2 & 244.2A Typical Delineation for Bike Facilities 80 Ft. Right-of-way	50.2 - 50.2A	"	"
244.3 Typical Delineation for Bike Facilities 60 Ft. Right-of-way (Parking on Both Sides)	50.3	"	"
246.1 Bike Lane Signing & Striping Intersection with Exclusive Right-Turn Lane	52.1	"	"

Released July 1995

NOTE:

SEE STANDARD DRAWING
NO. 245.1 (2 SHEETS) FOR
TYPICAL LANE CONFIGURATIONS
AND DIMENSIONS

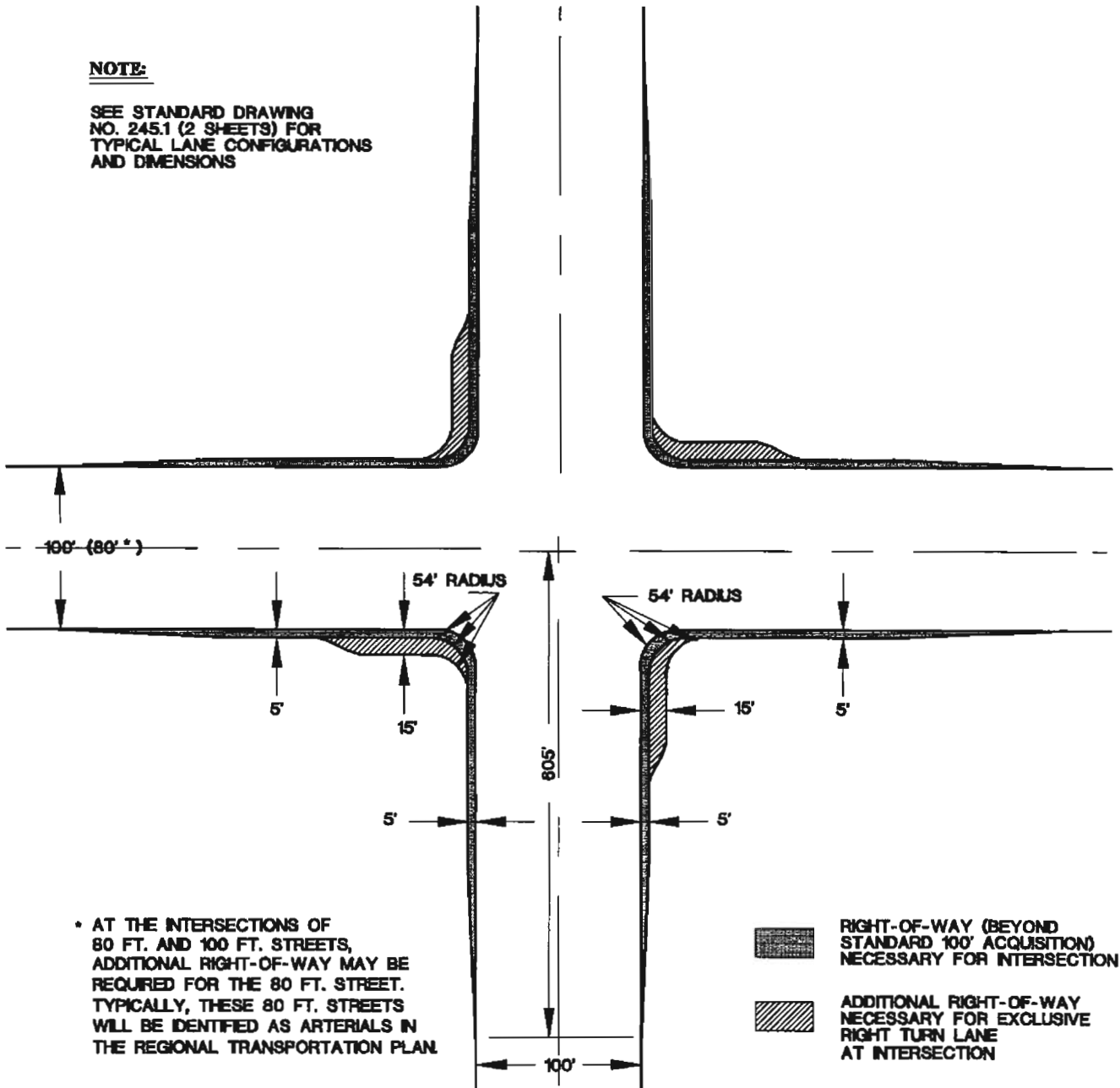

SPECIFICATION REFERENCE		UNIFORM STANDARD DRAWINGS CLARK COUNTY AREA	
		ADDITIONAL RIGHT-OF-WAY REQUIRED AT MAJOR INTERSECTIONS	
		DATE 6-9-94	DWG. NO. 2011
		PAGE NO.	7.1

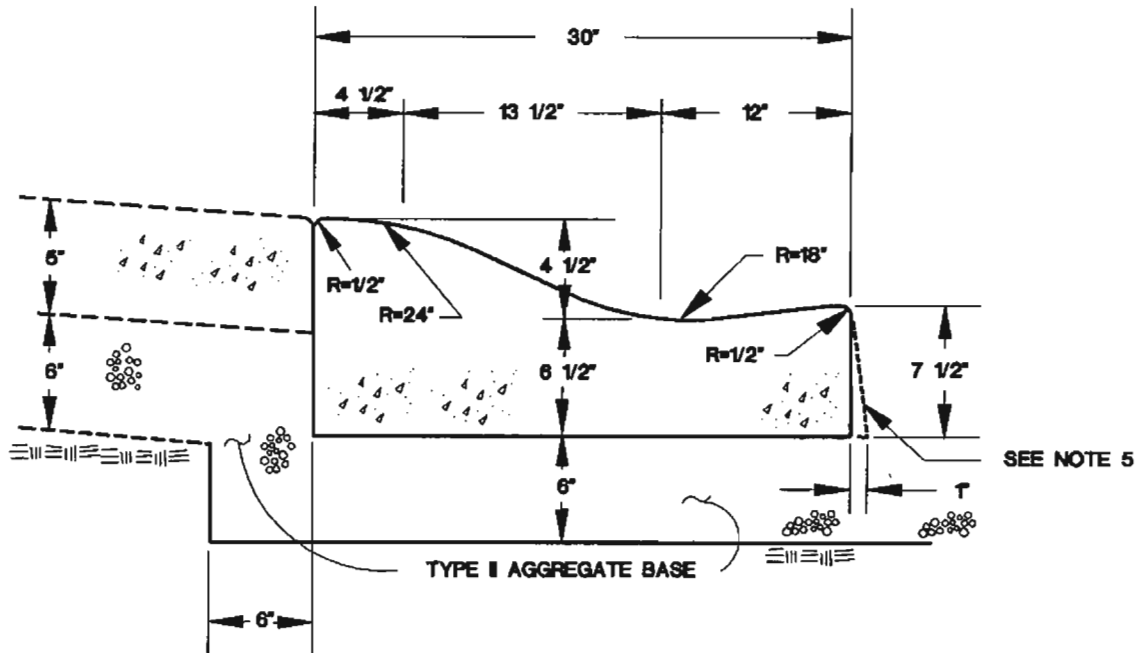

NOTES:

1. USE OF ROLL CURB MAY BE RESTRICTED BY SURFACE DRAINAGE CONSIDERATIONS.
2. SIDEWALK CONSTRUCTED CONTIGUOUS TO ROLL CURB SHALL BE 5 INCHES THICK (MIN).
3. WHERE LONGITUDINAL SLOPE IS LESS THAN 0.4% THE FLOW LINE SHALL BE WATER TESTED.
4. CONSTRUCT 1/2" EXPANSION JOINT AT ALL COLD JOINTS, AT BEGINNING AND END OF CURB RETURNS, AND AT 300 FT. MAX. INTERVALS FOR EXTRUDED CURB AND 30 FT. MAX. INTERVALS FOR FORMED CURB. WEAKENED PLANE JOINTS SHALL BE FORMED AT THE REMAINING 15 FT. INTERVALS. SEE STD. DWG. NO. 234 FOR JOINT DETAILS.
5. ONE INCH BATTER AT CURB FACE IS OPTIONAL.
6. CITY OF LAS VEGAS COUNCIL APPROVAL REQUIRED FOR USE OF 30" ROLL CURB IN THE CITY OF LAS VEGAS.
7. IN NORTH LAS VEGAS, ROLL CURBS ARE PROHIBITED IN AREAS WHERE FLOW LINE GRADIENT IS LESS THAN 0.8% UNLESS OTHERWISE APPROVED BY CITY ENGINEER.

SPECIFICATION REFERENCE		UNIFORM STANDARD DRAWINGS CLARK COUNTY AREA		
320	AGGREGATE BASE	CITIES OF LAS VEGAS & NORTH LAS VEGAS ONLY 30" ROLL CURB RESIDENTIAL AREA		
501	CONCRETE			
502	CONCRETE STRUCTURES			
707	JOINT MATERIAL			
		DATE 1-13-94	DWG. NO. 217A	PAGE NO. 23A

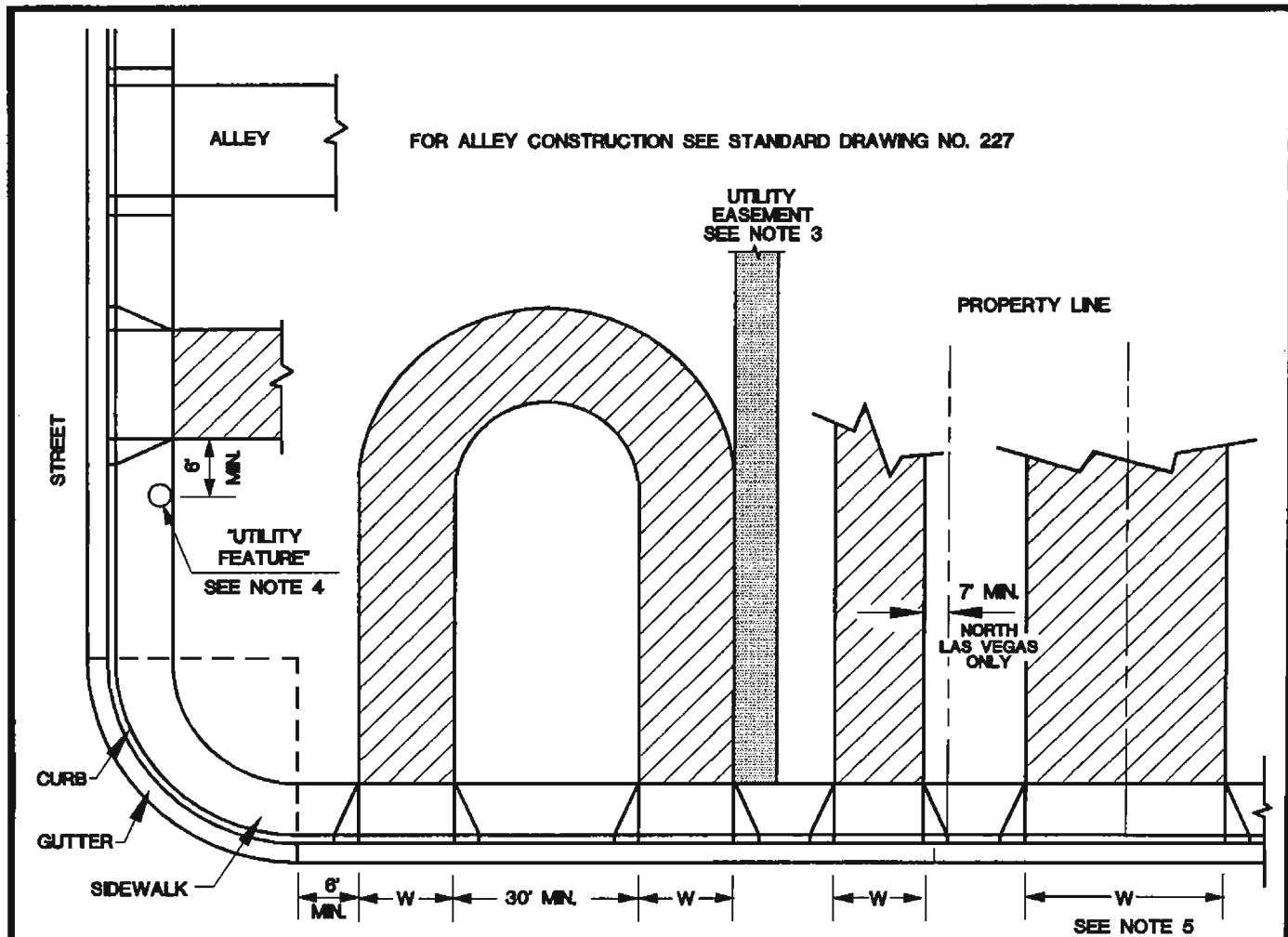

W = WIDTH OF DRIVEWAY = 12' MIN.
 18' MAX. FOR 1 OR 2 CAR GARAGE, OR
 28' MAX. FOR 3+ GARAGE

NOTES:

1. ALL RESIDENTIAL PROPERTIES MAY HAVE ONLY ONE CURB CUT EXCEPT CIRCULAR DRIVEWAYS AS SHOWN.
2. LOCAL ORDINANCES MAY APPLY AND SHALL HAVE PREFERENCE.
3. NO DRIVEWAY SHALL BE LOCATED WHOLLY OR PARTIALLY, ON OR OVER A UTILITY EASEMENT WHICH RUNS PERPENDICULAR TO THE CURB LINE.
4. NO DRIVEWAY SHALL BE LOCATED WITHIN 6 FEET OF A LIGHT POLE, FIRE HYDRANT, MAIL BOX, ABOVE-GROUND ELECTRICAL TRANSFER BOX, BLOCK WALL HIGHER THAN 2 FEET, OR THE CURB RETURN AT A STREET INTERSECTION OR ALLEY.
5. COMMON DRIVEWAY CONSTRUCTION MAY BE PERMITTED AT ANY TWO RESIDENTIAL PROPERTIES OF 60 FEET IN WIDTH OR LESS. THE WIDTH OF THE JOINT DRIVEWAY SHALL BE A MAXIMUM OF 24 FEET. A JOINT DRIVEWAY AGREEMENT SHALL BE REQUIRED.
6. GEOMETRICS APPLY TO NEW CONSTRUCTION ONLY, AND MAY VARY IN EXISTING SUBDIVISIONS SUBJECT TO APPROVAL OF THE ENGINEER.
7. MULTI-FAMILY RESIDENTIAL AND ALL NON-RESIDENTIAL DRIVEWAYS SHALL CONFORM TO THE COMMERCIAL DRIVEWAY STANDARDS.
8. ALL DRIVEWAY LOCATIONS SHALL BE SUBJECT TO REVIEW AND APPROVAL BY THE ENGINEER.
9. FOR CURB DEPRESSION AND DRIVEWAY APRON DETAIL, SEE STD. DWG. NO. 223.

SPECIFICATION REFERENCE	UNIFORM STANDARD DRAWINGS CLARK COUNTY AREA	
	RESIDENTIAL DRIVEWAY GEOMETRICS	
	DATE 1-13-94	DWG. NO. 222
	PAGE NO. 28	

DIMENSIONS	
W.	12' MINIMUM FOR ONE-WAY DRIVEWAYS 24' MINIMUM FOR TWO-WAY DRIVEWAYS 40' MAXIMUM
B.	20' MINIMUM & 25' MAXIMUM
C.	7' MINIMUM FACE TO FACE
E.	50' MINIMUM
H.	8' MINIMUM & 15' MAXIMUM
D.	THROAT DEPTH 25' MINIMUM 35' MINIMUM FOR PARKING LOTS OF > 50 CARS/DRIVE 65' MINIMUM FOR PARKING LOTS OF > 150 CARS/DRIVE 100' MINIMUM FOR PARKING LOTS OF > 300 CARS/DRIVE
R1 = 15' MIN. & 35' MAX. R2 = 25' MIN. & 35' MAX.	

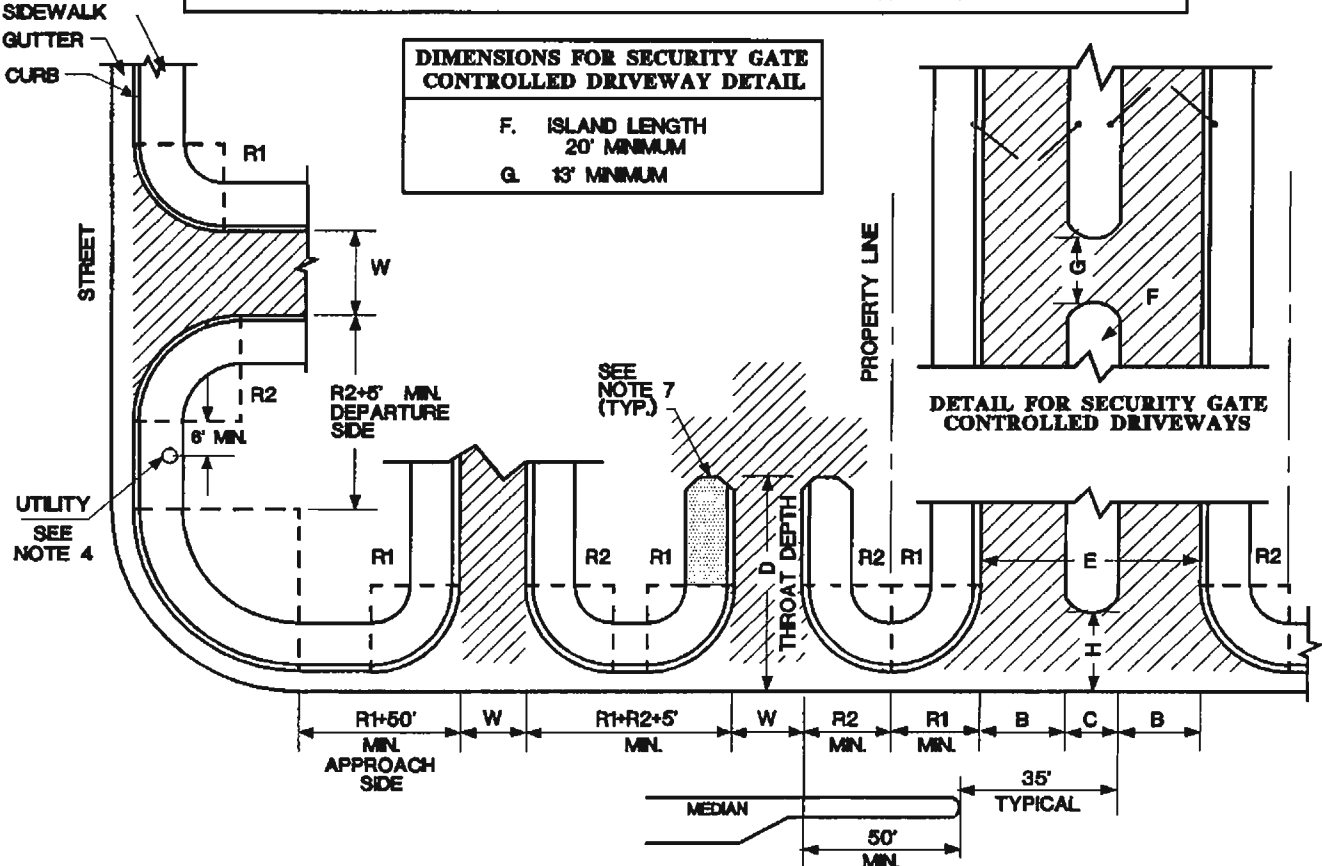

NOTES:

1. COMMERCIAL AND MULTI-FAMILY DRIVEWAYS SHALL BE CONSTRUCTED IN ACCORDANCE WITH STANDARD DRAWING NUMBERS 225, 228 & 235.
2. LOCAL ORDINANCES MAY APPLY AND SHALL HAVE PREFERENCE.
3. THE TOTAL WIDTH "W" OF DRIVEWAY CURB OPENINGS SHALL NOT EXCEED 85% OF FRONT FOOTAGE.
4. NO DRIVEWAY SHALL BE LOCATED WITHIN 6 FEET OF A LIGHT POLE, FIRE HYDRANT, MAIL BOX, ABOVE-GROUND ELECTRICAL TRANSFER BOX, OR BLOCK WALL HIGHER THAN 2 FEET.
5. THE CENTERLINES OF DRIVEWAYS ON OPPOSITE SIDES OF THE STREET AT A MEDIAN OPENING SHOULD BE $\pm 10'$ FROM EACH OTHER. WHEN A PROPERTY LINE FALLS IN A MEDIAN OPENING A JOINT DRIVEWAY AGREEMENT SHALL BE REQUIRED OR NO DRIVEWAY WILL BE ALLOWED.
6. GEOMETRICS APPLY TO NEW CONSTRUCTION ONLY, AND MAY VARY IN EXISTING DEVELOPMENTS SUBJECT TO APPROVAL OF THE ENGINEER.
7. HANDICAPPED ACCESSIBLE SIDEWALKS SHALL BE PROVIDED ADJACENT TO DRIVEWAYS TO THE P.C. OF THE CURB RETURN, MINIMUM.

SPECIFICATION REFERENCE	UNIFORM STANDARD DRAWINGS CLARK COUNTY AREA	
	COMMERCIAL AND MULTI-FAMILY DRIVEWAY GEOMETRICS	
	DATE 11-12-92	DWG. NO. 222A
		PAGE NO. 28A

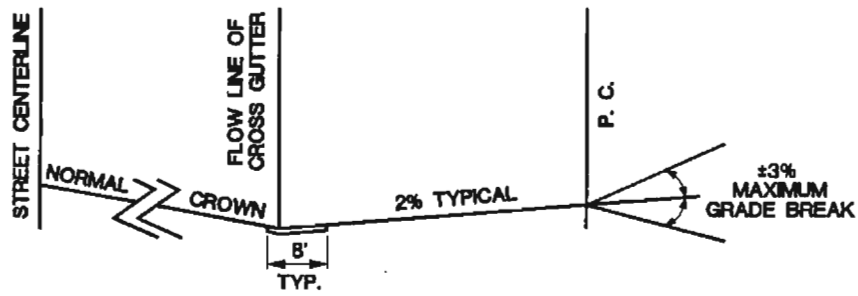
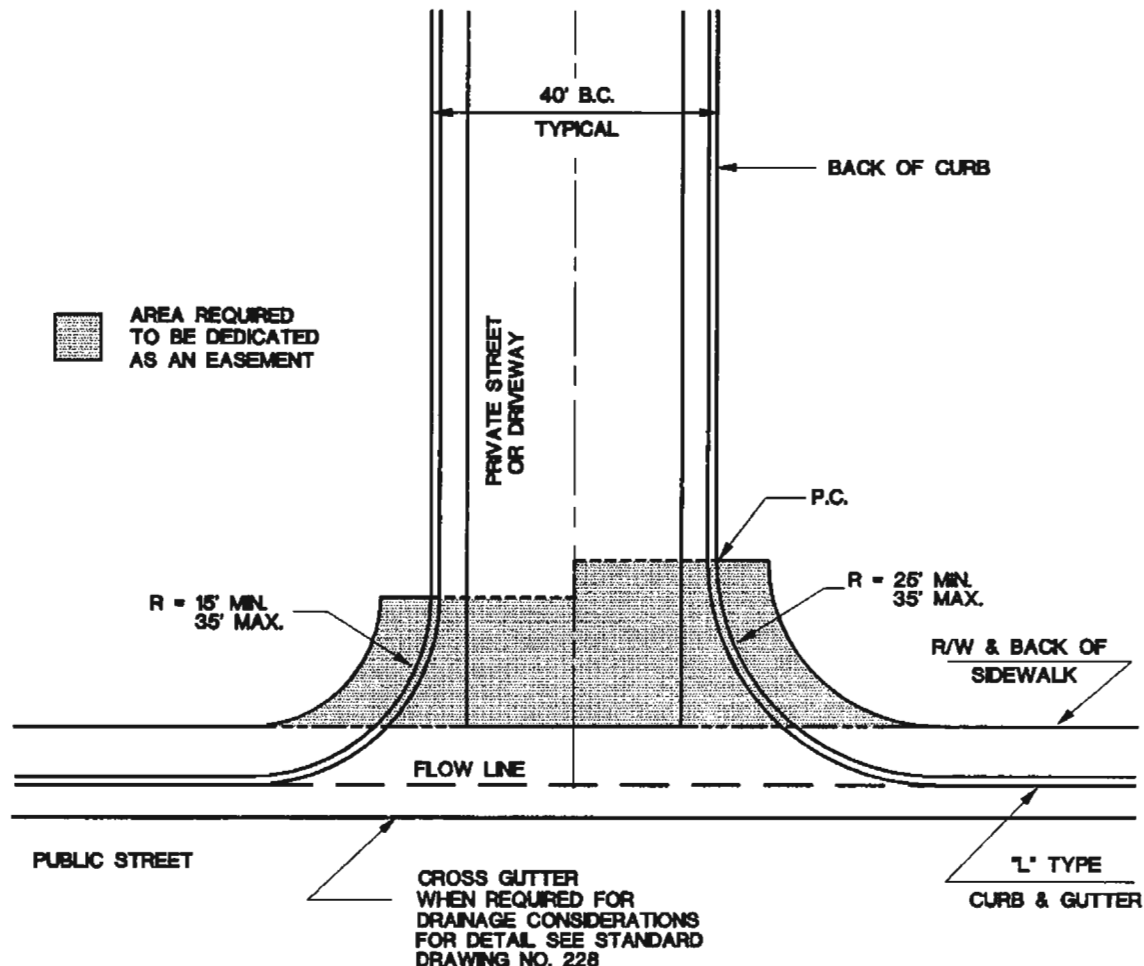

TYPICAL CROSS SECTION

NOTES:

1. SEPARATION OF PEDESTRIAN AND VEHICLE TRAFFIC MUST BE MAINTAINED ON SITE.
2. FOR GRADE CHANGES GREATER THAN 3%, VERTICAL CURVES OF AT LEAST 10 FEET MUST BE USED.
3. WHEELCHAIR RAMP SHALL BE CONSTRUCTED IN THE CURB RETURN IN ACCORDANCE WITH STANDARD DRAWING NO. 235.

SPECIFICATION REFERENCE	UNIFORM STANDARD DRAWINGS CLARK COUNTY AREA		
	COMMERCIAL AND INDUSTRIAL DRIVEWAY (OPTION B) OR PRIVATE STREET ACCESS		
	DATE 2-11-93	DWG. NO. 225	PAGE NO. 31

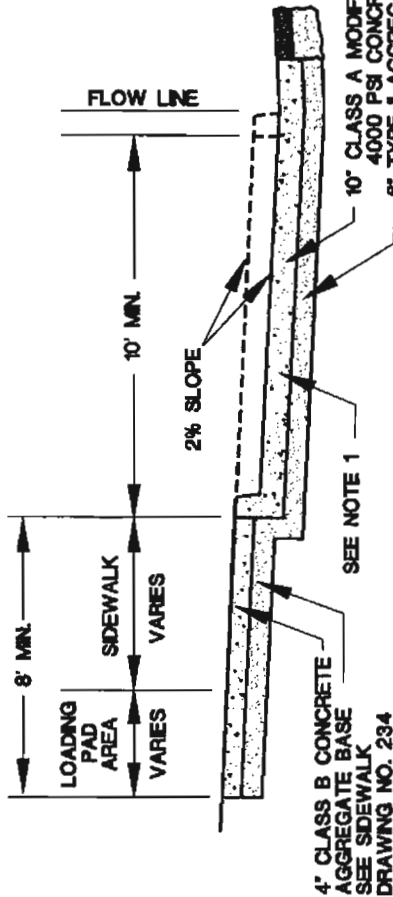
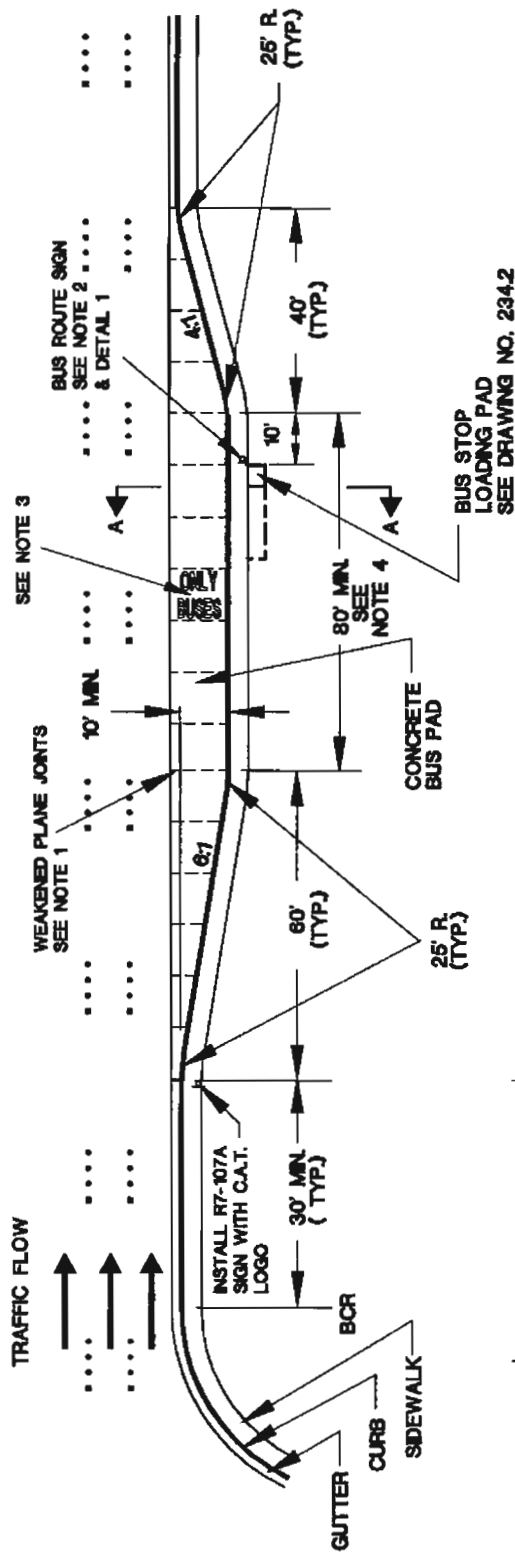

SECTION A-A

NOTES:

1. CONCRETE BUS PAD SHALL BE MONOLITHIC. TRANSVERSE WEAKENED PLANE JOINTS SHALL BE INSTALLED AT 10' INTERVALS AND AS DETAILED IN STANDARD DRAWING NO. 233, TYPE 'C'.
2. BUS ROUTE SIGN SHALL BE INSTALLED AT THE DOWNSTREAM END OF BUS STOP LOADING PAD.
3. A MINIMUM OF ONE SET OF PAVEMENT MARKINGS CONTAINING THE 'BUSES ONLY' SYMBOL SHALL BE PLACED IN THE TURN-OUT AREA. EXACT LOCATION TO BE DETERMINED BY THE ENGINEER.
4. ADDITIONAL STORAGE AREA WILL BE REQUIRED WHEN MORE THAN ONE BUS IS EXPECTED TO OCCUPY THE TURN-OUT AT THE SAME TIME.
5. ALTERNATE CONCRETE AND BASE THICKNESSES MAY BE SUBSTITUTED, BUT MUST BE SUPPORTED BY ENGINEERING ANALYSIS AND APPROVED BY THE ENGINEER.
6. TURN-OUT SURFACE SHALL BE TEXTURED IN ACCORDANCE WITH UNIFORM STANDARD SPECIFICATION NO. 409.03.08. FLOW LINE SHALL NOT BE TEXTURED, BUT SHALL BE A TROWELED SURFACE.

(ROUTE #)

DETAIL 1
BUS ROUTE SIGN

SPECIFICATION REFERENCE	
302	AGGREGATE BASE
501	CONCRETE
502	CONCRETE STRUCTURES

UNIFORM STANDARD DRAWINGS
CLARK COUNTY AREA

TYPICAL BUS TURN-OUT

DATE 6-9-94	DWG. NO. 234.1	PAGE 40.1
-------------	----------------	-----------

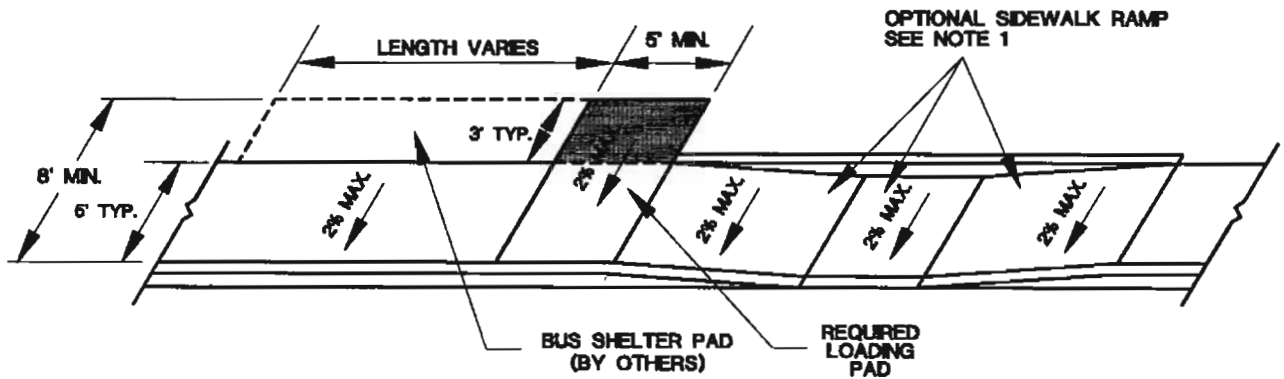

ADDITIONAL AREA REQUIRED BEHIND
SIDEWALK FOR LOADING PAD

NOTES:

1. SIDEWALK RAMP MAY BE REQUIRED TO BE CONSTRUCTED IN THOSE LOCATIONS WHERE THE BUS STOP WOULD OTHERWISE BE INACCESSIBLE AS DEFINED BY THE AMERICANS WITH DISABILITIES ACT. SEE DRAWING NO. 235, SHEET 4 OF 5 FOR SIDEWALK RAMP DETAILS.
2. ADDITIONAL RIGHT-OF-WAY OR EASEMENT IS REQUIRED FOR LOADING PAD AND VARIABLE HEIGHT CURB AT BACK OF SIDEWALK RAMP.
3. AGGREGATE BASE AND CONCRETE FOR LOADING PAD SHALL BE THE SAME AS REQUIRED FOR SIDEWALK. SEE DRAWING NO. 234.

SPECIFICATION REFERENCE		UNIFORM STANDARD DRAWINGS CLARK COUNTY AREA	
302	AGGREGATE BASE	BUS STOP LOADING PAD AND OPTIONAL SIDEWALK RAMP	
501	CONCRETE		
502	CONCRETE STRUCTURES		
		DATE 8-9-94	DWG. NO. 234.2
			PAGE 40.2

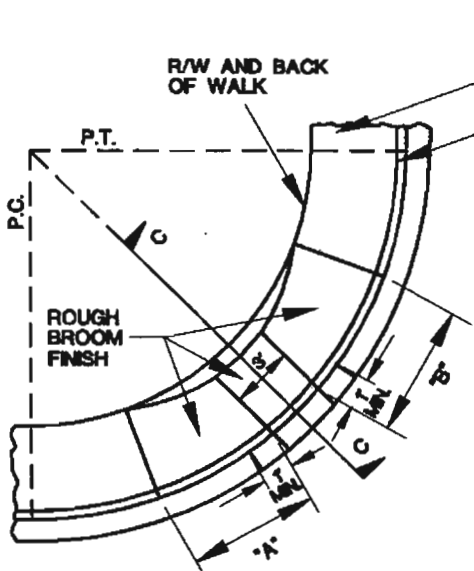

RAMP IN CURB RETURN

"A" AND "B" ARE EQUAL TO 8' WHEN FLOW LINE GRADE IS BETWEEN -2% AND +2%. FOR "A" AND "B" AT OTHER FLOW LINE GRADES, SEE TABLE 1 SHEET 5 THIS DRAWING NO.

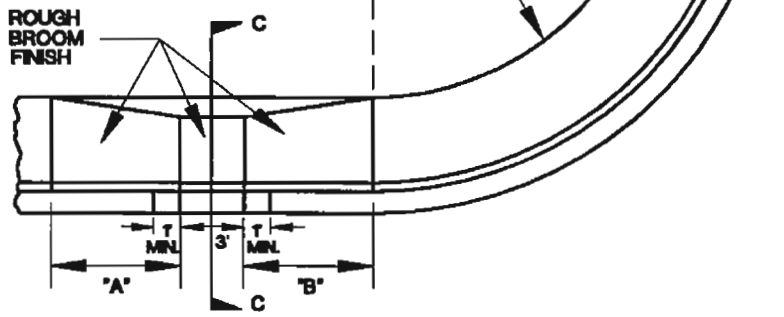

RAMP OUTSIDE CURB RETURN

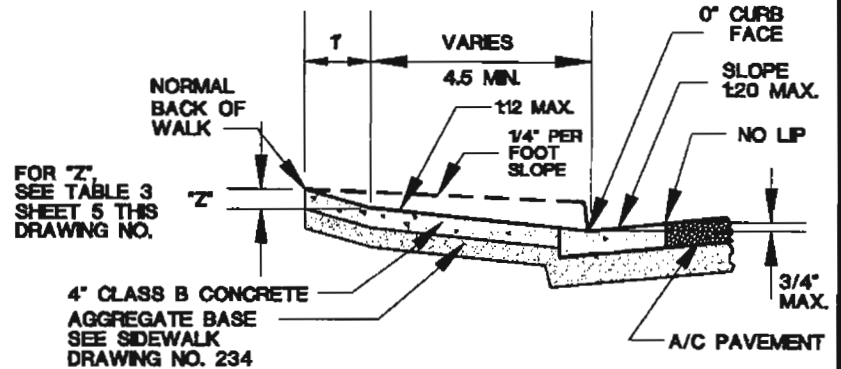

SECTION C-C

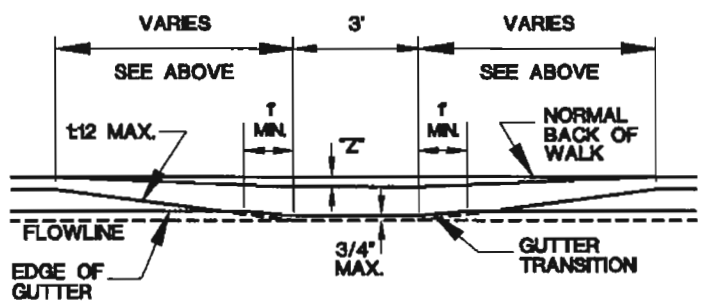

PROFILE

CONSTRUCTION OF THE CASE I ALTERNATIVE IS PREFERRED OVER CASE II

NOTES:

1. SIDEWALK RAMP WITHIN CURB RETURN SHALL BE LOCATED AT THE MIDPOINT OF CURB RETURN UNLESS OTHERWISE APPROVED.
2. SIDEWALK RAMPS OUTSIDE OF THE CURB RETURN SHALL BE LOCATED ADJACENT TO THE RETURN.
3. RAMPS SHALL BE CONSTRUCTED WITH A ROUGH BROOM FINISH TRANSVERSE TO THE SLOPE OF THE RAMP.
4. WHEN CONSTRUCTING RAMP WHERE CURB & GUTTER EXISTS, COMPLETELY REMOVE INTERFERING PORTIONS OF EXISTING CURB & GUTTER.
5. AN OPTIONAL DETECTABLE WARNING CONSISTING OF RAISED TRUNCATED DOMES WITH A DIAMETER OF NOMINAL 0.9 IN., A HEIGHT OF NOMINAL 0.2 IN. AND A CENTER-TO-CENTER SPACING OF NOMINAL 2.35 IN. AND CONTRASTING VISUALLY WITH ADJOINING SURFACES MAY BE PLACED ON RAMP EXTENDING THE FULL WIDTH AND DEPTH OF THE RAMP.

SPECIFICATION REFERENCE	
302	AGGREGATE BASE
501	CONCRETE
502	CONCRETE STRUCTURES

**UNIFORM STANDARD DRAWINGS
CLARK COUNTY AREA**

**SIDEWALK RAMP
CASE I**

DATE 8-13-92 | DWG. NO. 235 (1 OF 5) | PAGE 41

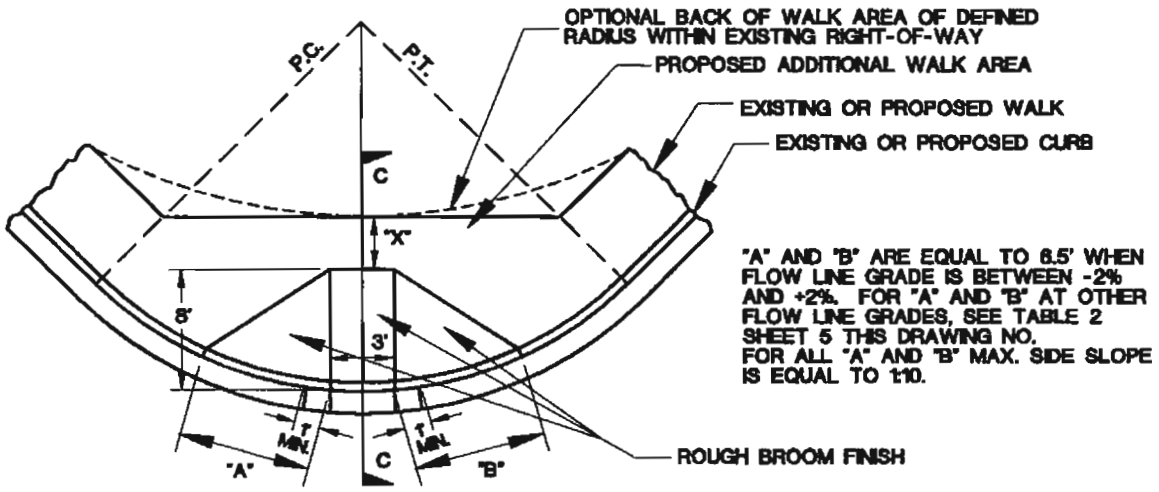

RAMP IN CURB RETURN
(NO BACK OF WALK DEPRESSION)

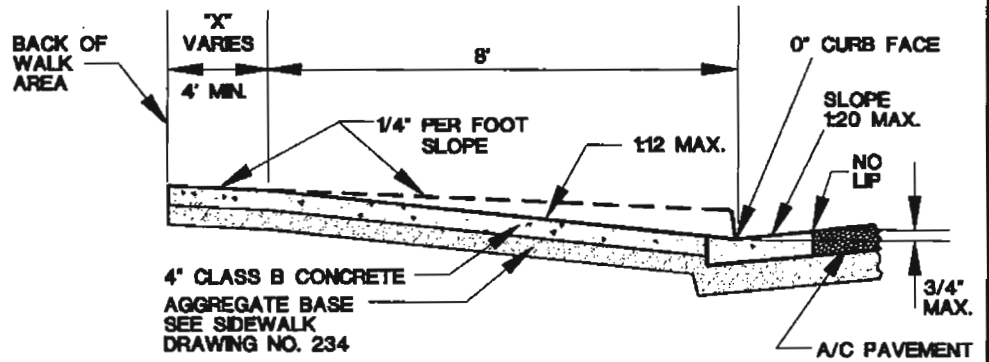

SECTION C-C

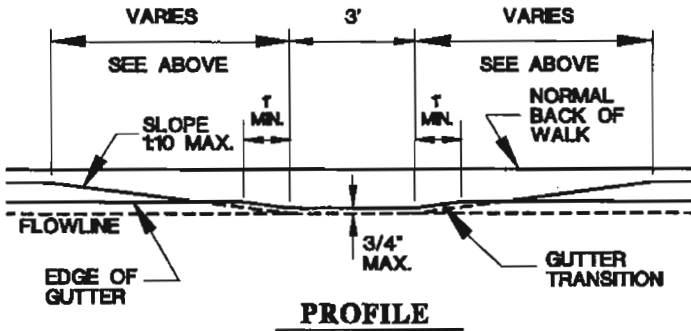

CASE II SHALL BE USED WHERE R/W AND FIELD CONDITIONS PERMIT.

NOTES:

1. SIDEWALK RAMP WITHIN CURB RETURN SHALL BE LOCATED AT THE MIDPOINT OF CURB RETURN UNLESS OTHERWISE APPROVED.
2. RAMPS SHALL BE CONSTRUCTED WITH A ROUGH BROOM FINISH TRANSVERSE TO THE SLOPE OF THE RAMP.
3. WHEN CONSTRUCTING RAMP WHERE CURB & GUTTER EXISTS, COMPLETELY REMOVE INTERFERING PORTIONS OF EXISTING CURB & GUTTER.
4. AN OPTIONAL DETECTABLE WARNING CONSISTING OF RAISED TRUNCATED DOMES WITH A DIAMETER OF NOMINAL 0.9 IN., A HEIGHT OF NOMINAL 0.2 IN. AND A CENTER-TO-CENTER SPACING OF NOMINAL 2.35 IN. AND CONTRASTING VISUALLY WITH ADJOINING SURFACES MAY BE PLACED ON RAMP EXTENDING THE FULL WIDTH AND DEPTH OF THE RAMP.

SPECIFICATION REFERENCE	
302	AGGREGATE BASE
501	CONCRETE
502	CONCRETE STRUCTURES

UNIFORM STANDARD DRAWINGS CLARK COUNTY AREA		
SIDEWALK RAMP CASE II		
DATE 8-13-92	DWG. NO. 235 (2 OF 5)	PAGE 41A

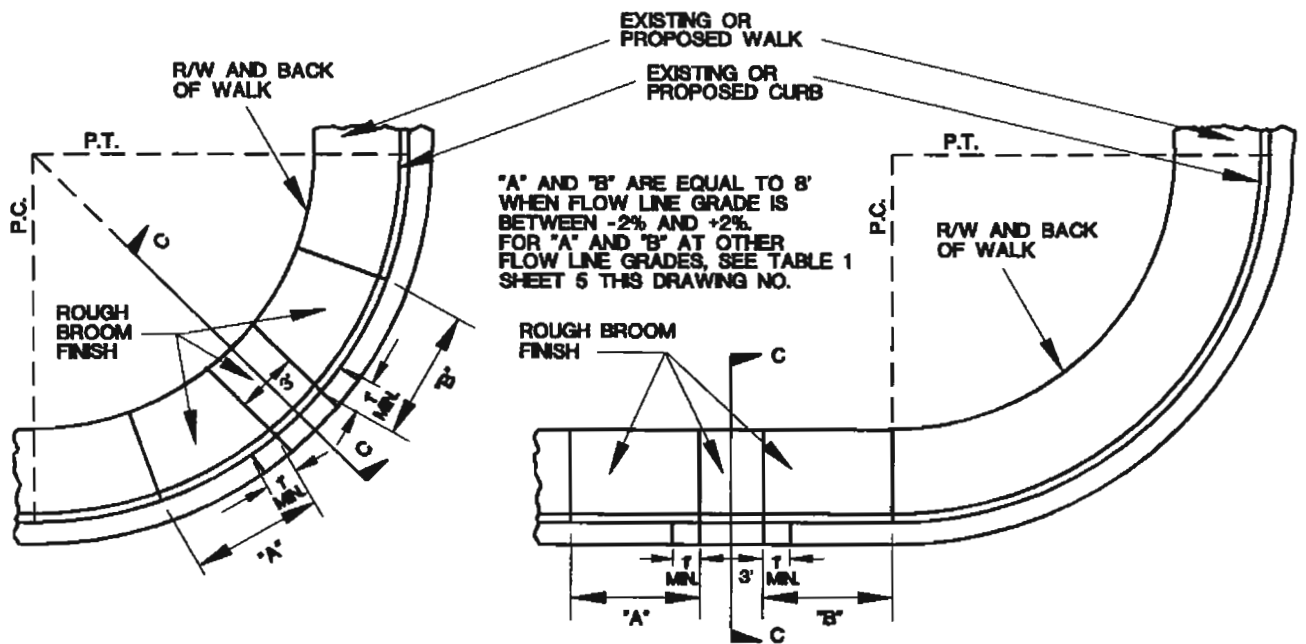

"A" AND "B" ARE EQUAL TO 8' WHEN FLOW LINE GRADE IS BETWEEN -2% AND +2%. FOR "A" AND "B" AT OTHER FLOW LINE GRADES, SEE TABLE 1 SHEET 5 THIS DRAWING NO.

RAMP IN CURB RETURN

RAMP OUTSIDE CURB RETURN

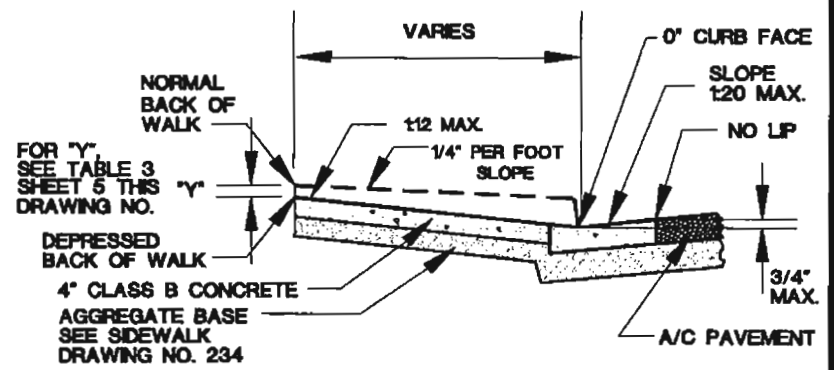

SECTION C-C

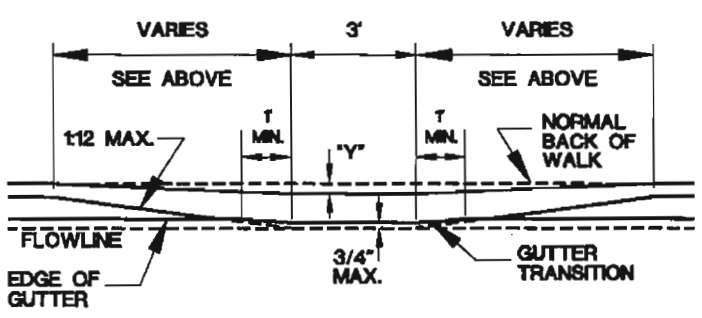

PROFILE

NOTES:

1. SIDEWALK RAMP WITHIN CURB RETURN SHALL BE LOCATED AT THE MIDPOINT OF CURB RETURN UNLESS OTHERWISE APPROVED.
2. SIDEWALK RAMPS OUTSIDE OF THE CURB RETURN SHALL BE LOCATED ADJACENT TO THE RETURN.
3. RAMPS SHALL BE CONSTRUCTED WITH A ROUGH BROOM FINISH TRANSVERSE TO THE SLOPE OF THE RAMP.
4. WHEN CONSTRUCTING RAMP WHERE CURB & GUTTER EXISTS, COMPLETELY REMOVE INTERFERING PORTIONS OF EXISTING CURB & GUTTER.
5. AN OPTIONAL DETECTABLE WARNING CONSISTING OF RAISED TRUNCATED DOMES WITH A DIAMETER OF NOMINAL 0.9 IN., A HEIGHT OF NOMINAL 0.2 IN. AND A CENTER-TO-CENTER SPACING OF NOMINAL 2.35 IN. AND CONTRASTING VISUALLY WITH ADJOINING SURFACES MAY BE PLACED ON RAMP EXTENDING THE FULL WIDTH AND DEPTH OF THE RAMP.

CASE III TO BE USED ONLY WHEN APPROVED BY THE ENGINEER.

SPECIFICATION REFERENCE		UNIFORM STANDARD DRAWINGS CLARK COUNTY AREA		
302	AGGREGATE BASE			
501	CONCRETE	SIDEWALK RAMP CASE III		
502	CONCRETE STRUCTURES			
		DATE 8-13-92	DWG. NO. 235 (3 OF 5)	PAGE 41B

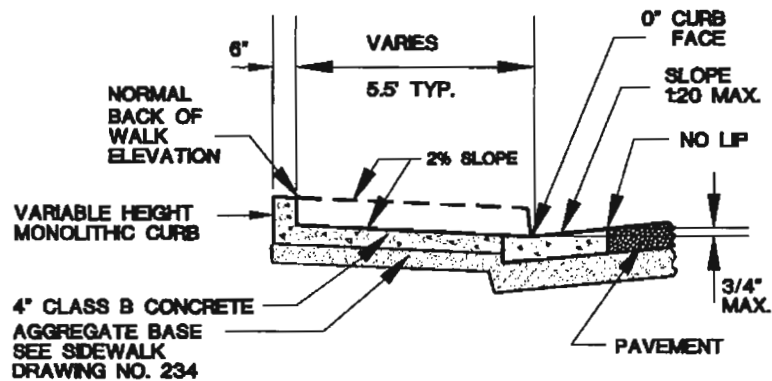
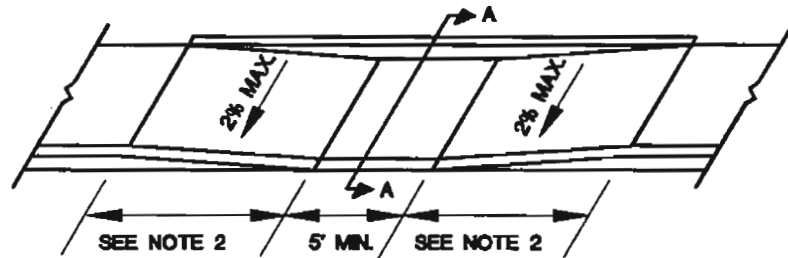

SECTION A-A

NOTES:

1. ADDITIONAL RIGHT-OF-WAY OR EASEMENT IS REQUIRED FOR VARIABLE HEIGHT CURB AT BACK OF SIDEWALK RAMP.
2. MAXIMUM SLOPE IS 1:12. SEE SHEET 5 THIS DRAWING NO. FOR RAMP TRANSITION LENGTHS.
3. SIDEWALK RAMP SHALL BE CONSTRUCTED WITH A ROUGH BROOM FINISH TRANSVERSE TO THE SLOPE OF THE RAMP.
4. WHEN CONSTRUCTING RAMP WHERE CURB AND GUTTER EXISTS, COMPLETELY REMOVE INTERFERING PORTIONS OF CURB & GUTTER.
5. AN OPTIONAL DETECTABLE WARNING CONSISTING OF RAISED TRUNCATED DOMES WITH A DIAMETER OF NOMINAL 0.9 IN., A HEIGHT OF NOMINAL 0.2 IN. AND A CENTER-TO-CENTER SPACING OF NOMINAL 2.35 IN. AND CONTRASTING VISUALLY WITH ADJOINING SURFACES MAY BE PLACED ON RAMP EXTENDING THE FULL WIDTH AND DEPTH OF THE RAMP.

SPECIFICATION REFERENCE		UNIFORM STANDARD DRAWINGS CLARK COUNTY AREA		
302	AGGREGATE BASE	SIDEWALK RAMP CASE IV		
501	CONCRETE			
502	CONCRETE STRUCTURES			
		DATE 6-9-94	DWG. NO. 235 (4 OF 5)	PAGE 41C

GRADE (%) "B" TO "A"	"A" (FT) MIN.	"B" (FT) MIN.
-6 TO -5.01	4.5	21.5
-5 TO -4.01	4.5	15.0
-4 TO -3.01	4.5	12.0
-3 TO -2.01	4.5	9.5
-2 TO 2	8.0	8.0
2.01 TO 3	9.5	4.5
3.01 TO 4	12.0	4.5
4.01 TO 5	15.0	4.5
5.01 TO 6	21.5	4.5

TABLE 1. TRANSITION LENGTHS FOR 1:12 SIDE SLOPES

GRADE (%) "B" TO "A"	"A" (FT) MIN.	"B" (FT) MIN.
-6 TO -5.01	4.0	12.5
-5 TO -4.01	4.0	10.0
-4 TO -3.01	4.0	8.5
-3 TO -2.01	4.0	7.5
-2 TO 2	8.5	8.5
2.01 TO 3	7.5	4.0
3.01 TO 4	8.5	4.0
4.01 TO 5	10.0	4.0
5.01 TO 6	12.5	4.0

TABLE 2. TRANSITION LENGTHS FOR 1:10 SIDE SLOPES

SIDEWALK WIDTH (FT)	"Y" (IN) MIN.	"Z" (IN) MIN.
4	2.75	3.50 (USE CASE II)
5	2.00	2.75
6	1.25	2.00

TABLE 3. DEPTH OF DEPRESSION

NOTE:

CHARTS APPLY TO CURB WITH 6" CURB FACE.
IF CURB HAS GREATER THAN A 6" CURB FACE,
A SPECIAL DESIGN IS REQUIRED.

SPECIFICATION REFERENCE		UNIFORM STANDARD DRAWINGS CLARK COUNTY AREA	
302	AGGREGATE BASE	SIDEWALK RAMP	
501	CONCRETE		
502	CONCRETE STRUCTURES		
		DATE 8-13-92	DWG. NO. 235 (5 OF 5) PAGE 41D

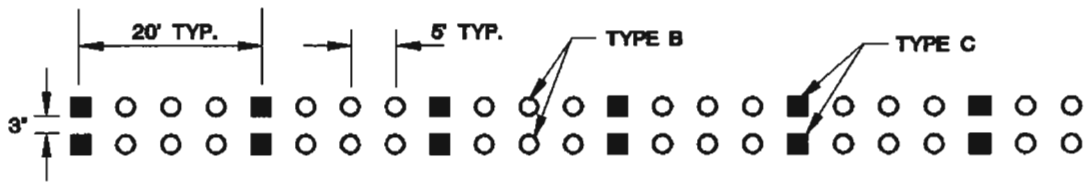

TYPE 1 CENTERLINE

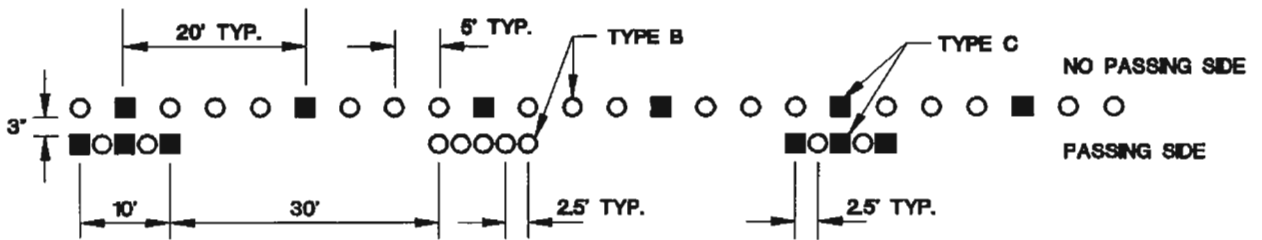

TYPE 2 CENTERLINE

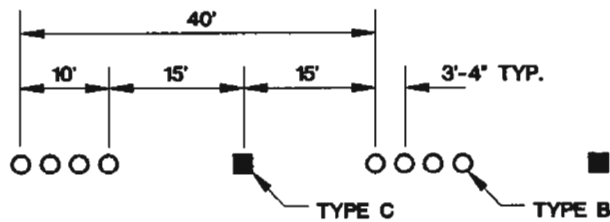

TYPE 3 CENTERLINE

SPECIFICATION REFERENCE		UNIFORM STANDARD DRAWINGS CLARK COUNTY AREA		
633	PAVEMENT MARKERS			
		TYPICAL CENTERLINE DELINEATION		
		DATE 6-11-93	DWG. NO. 244	PAGE NO. 50

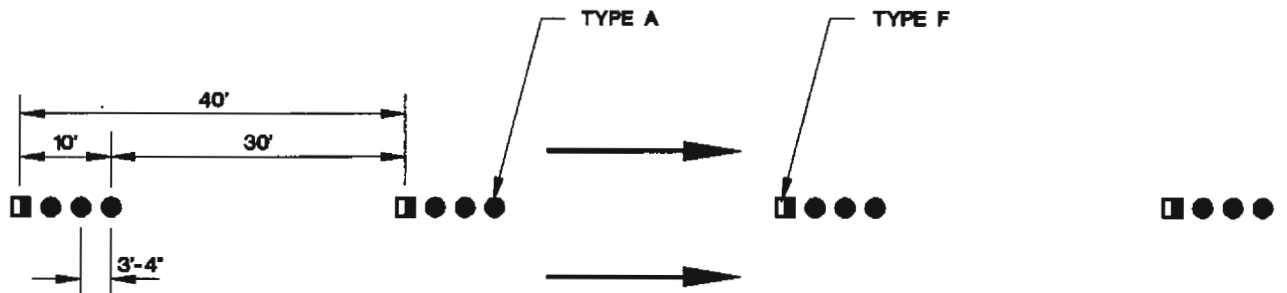

TYPE 4 LANE LINE
 (DIVIDED OR ONE-WAY ROADWAY)

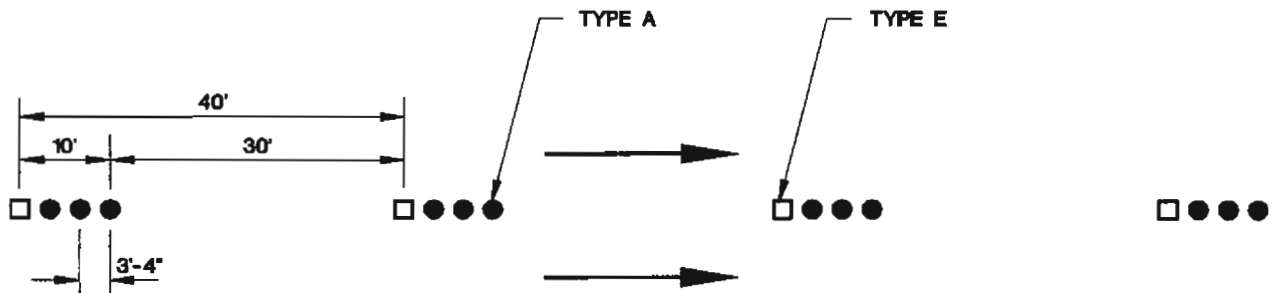

TYPE 5 LANE LINE
 (UNDIVIDED ROADWAY)

SPECIFICATION REFERENCE		UNIFORM STANDARD DRAWINGS CLARK COUNTY AREA	
633	PAVEMENT MARKERS	TYPICAL LANE LINE DELINEATION	
		DATE 6-11-93	DWG. NO. 244A
		PAGE NO. 50A	

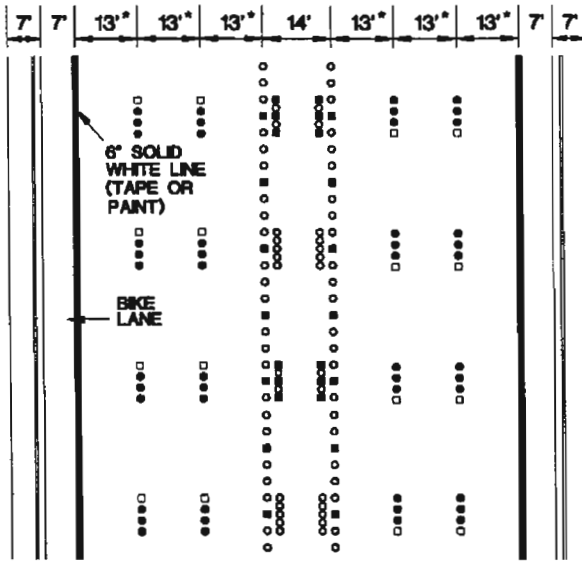

**120 FT. STREET WITH BIKE LANE
(WITHOUT PARKING)**

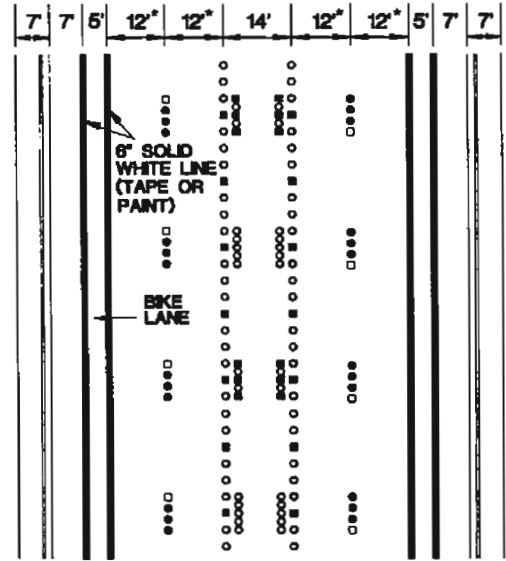

**100 FT. STREET WITH BIKE LANE
(WITH PARKING/EMERGENCY LANE)**

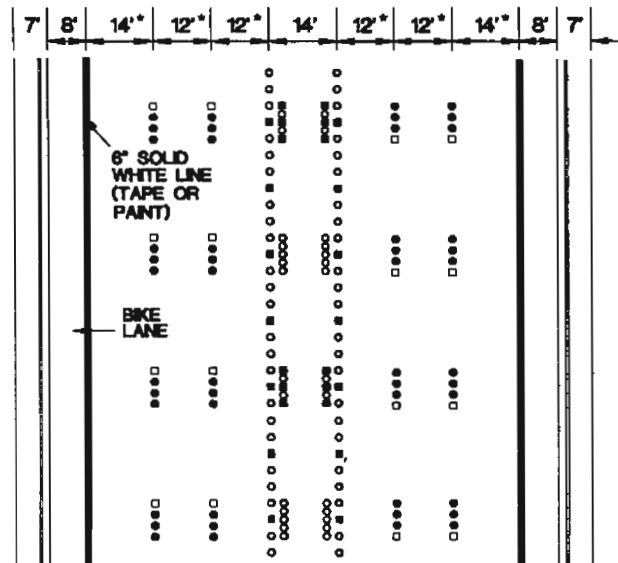

**120 FT. STREET WITH BIKE LANE
(WITHOUT PARKING)**

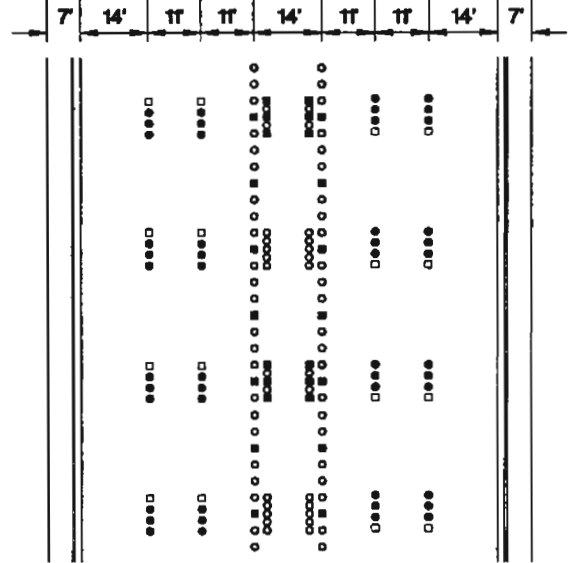

**100 FT. STREET WITH SHARED
BIKE/VEHICLE LANE (WITHOUT PARKING)**

- THE WIDTH OF TRAVEL LANES ADJACENT TO BIKE LANES MAY VARY FROM 12 FT. TO 16 FT. WIDTHS OF INTERIOR TRAVEL LANES MAY VARY FROM 11 FT. TO 13 FT.

NOTES:

1. LANE LINE DELINEATION SHALL COMPLY WITH STANDARD DRAWING NOS. 244 & 244A.
2. IN SOME CASES, A MEDIAN WILL EXIST INSTEAD OF TWO-WAY LEFT TURN LANE.
3. BIKE LANES MUST BE A MINIMUM OF 4 FT. AND NO GREATER THAN 8 FT. WIDE; HOWEVER, A WIDTH OF 5 FT. IS PREFERRED.
4. WHERE 8 FT. SIDEWALK EXISTS, WIDTH OF MEDIAN MAY BE REDUCED BY 2 FT. OR TRAVEL LANES MAY BE REDUCED TO 11 FT.
5. ALL CURB LANES ARE MEASURED TO LIP OF GUTTER OR EDGE OF PAVEMENT IF CURB AND GUTTER DO NOT EXIST.

SPECIFICATION REFERENCE		UNIFORM STANDARD DRAWINGS CLARK COUNTY AREA		
628	PAINTING TRAFFIC STRIPING	TYPICAL DELINEATION FOR BIKE FACILITIES 100 FT. OR GREATER RIGHT-OF-WAY		
633	PAVEMENT MARKERS			
		DATE 6-8-95	DWG. NO. 244.1	PAGE NO. 50.1

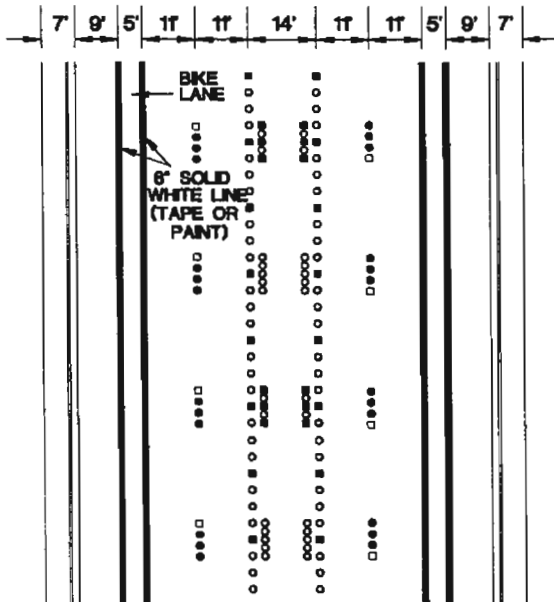

**100 FT. STREET WITH BIKE LANE
(WITH PARKING/EMERGENCY LANE)**

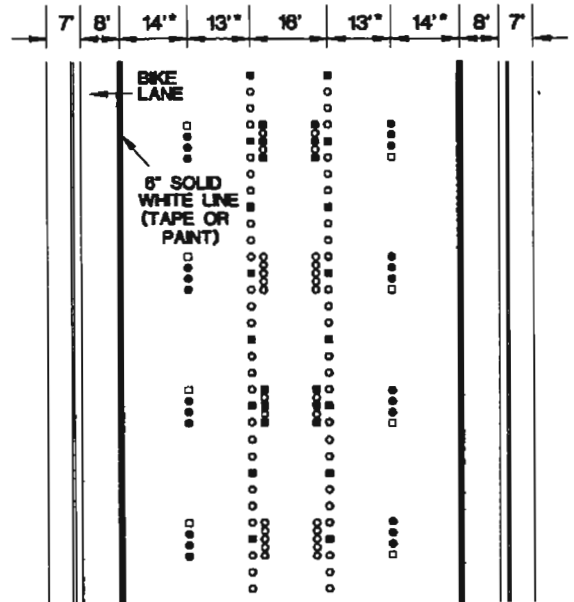

**100 FT. STREET WITH BIKE LANE
(WITHOUT PARKING/EMERGENCY LANE)**

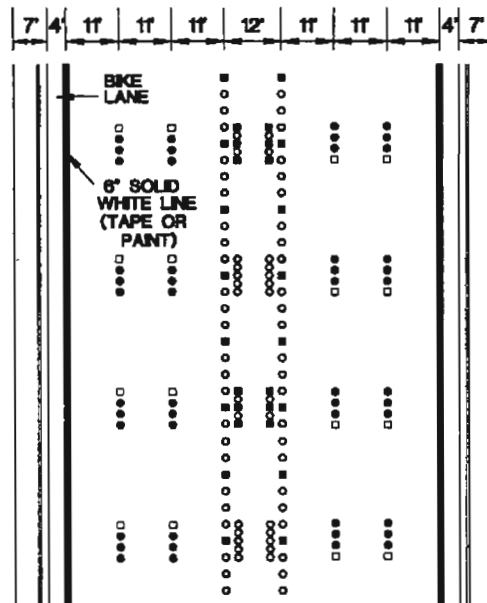

**100 FT. STREET WITH BIKE LANE
(WITHOUT PARKING/EMERGENCY LANE)**

• THE WIDTH OF TRAVEL LANES ADJACENT TO BIKE LANES MAY VARY FROM 12 FT. TO 16 FT. WIDTHS OF INTERIOR TRAVEL LANES MAY VARY FROM 11 FT. TO 13 FT.

NOTES:

1. LANE LINE DELINEATION SHALL COMPLY WITH STANDARD DRAWING NOS. 244 & 244A.
2. IN SOME CASES, A MEDIAN WILL EXIST INSTEAD OF TWO-WAY LEFT TURN LANE.
3. BIKE LANES MUST BE A MINIMUM OF 4 FT. AND NO GREATER THAN 8 FT. WIDE; HOWEVER, A WIDTH OF 5 FT. IS PREFERRED.
4. WHERE 8 FT. SIDEWALK EXISTS, WIDTH OF MEDIAN MAY BE REDUCED BY 2 FT. OR TRAVEL LANES MAY BE REDUCED TO 11 FT.
5. ALL CURB LANES ARE MEASURED TO LIP OF GUTTER OR EDGE OF PAVEMENT IF CURB AND GUTTER DO NOT EXIST.

SPECIFICATION REFERENCE		UNIFORM STANDARD DRAWINGS CLARK COUNTY AREA		
628	PAINTING TRAFFIC STRIPING	TYPICAL DELINEATION FOR BIKE FACILITIES 100 FT. RIGHT-OF-WAY		
633	PAVEMENT MARKERS			
		DATE 6-8-95	DWG. NO. 244.1A	PAGE NO. 50.1A

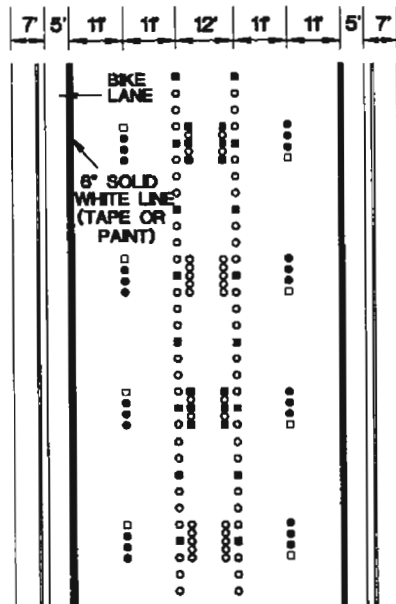

**80 FT. STREET WITH BIKE LANE
(WITHOUT PARKING/EMERGENCY LANE)**

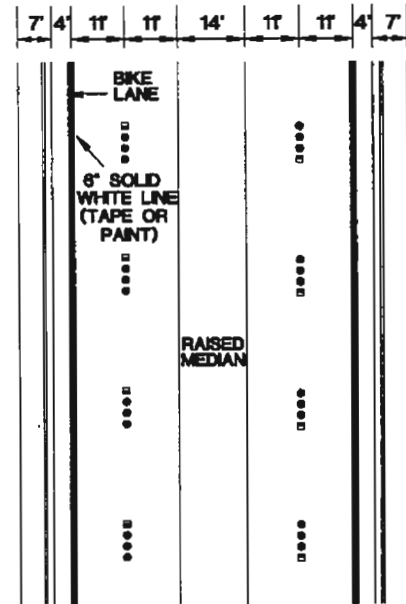

**80 FT. STREET WITH BIKE LANE
(WITHOUT PARKING/EMERGENCY LANE)**

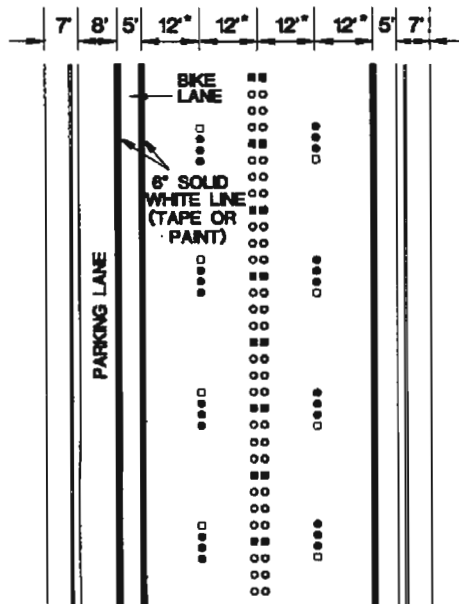

**80 FT. STREET WITH BIKE LANE
(WITH PARKING ON ONE SIDE)**

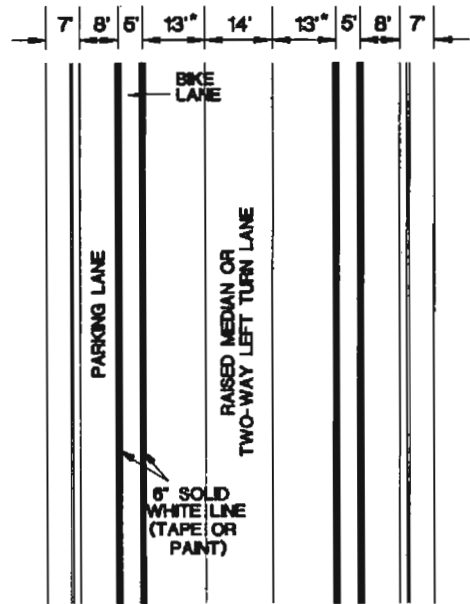

**80 FT. STREET WITH BIKE LANE
(WITH PARKING ON BOTH SIDES)**

• THE WIDTH OF TRAVEL LANE MAY VARY FROM 11 FT. TO 13 FT.

NOTES:

1. LANE LINE DELINEATION SHALL COMPLY WITH STANDARD DRAWING NOS. 244 & 244A.
2. BIKE LANES MUST BE A MINIMUM OF 4 FT. AND NO GREATER THAN 8 FT. WIDE; HOWEVER, A WIDTH OF 5 FT. IS PREFERRED.
3. WHERE 6 FT. SIDEWALK EXISTS, WIDTH OF MEDIAN MAY BE REDUCED BY 2 FT. OR TRAVEL LANES MAY BE REDUCED TO 11 FT.
4. ALL CURB LANES ARE MEASURED TO LIP OF GUTTER OR EDGE OF PAVEMENT IF CURB AND GUTTER DO NOT EXIST.

SPECIFICATION REFERENCE		UNIFORM STANDARD DRAWINGS CLARK COUNTY AREA		
628	PAINTING TRAFFIC STRIPING	TYPICAL DELINEATION FOR BIKE FACILITIES 80 FT. RIGHT-OF-WAY		
633	PAVEMENT MARKERS			
		DATE 6-8-95	DWG. NO. 244.2	PAGE NO. 50.2

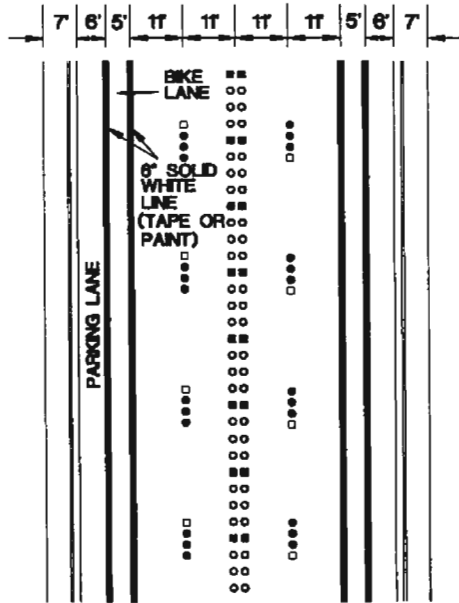

**80 FT. STREET WITH BIKE LANE
(WITH PARKING ON BOTH SIDES)**

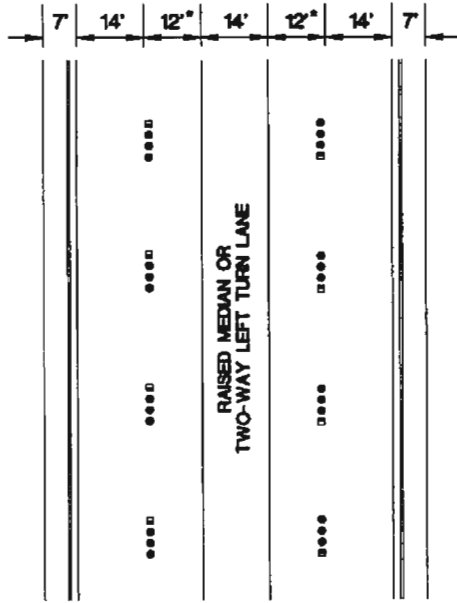

* WIDTH OF TRAVEL LANE MAY VARY FROM 11 FT. TO 12 FT.

**80 FT. STREET WITH SHARED BIKE/VEHICLE LANE
(WITHOUT PARKING/EMERGENCY LANE)**

NOTES:

1. LANE LINE DELINEATION SHALL COMPLY WITH STANDARD DRAWING NO. 244 & 244A.
2. BIKE LANES MUST BE A MINIMUM OF 4 FT. AND NO GREATER THAN 8 FT. WIDE; HOWEVER, A WIDTH OF 5 FT. IS PREFERRED.
3. WHERE 6 FT. SIDEWALK EXISTS, WIDTH OF MEDIAN MAY BE REDUCED BY 2 FT. OR TRAVEL LANES MAY BE REDUCED TO 11 FT.
4. ALL CURB LANES ARE MEASURED TO LIP OF GUTTER OR EDGE OF PAVEMENT IF CURB AND GUTTER DO NOT EXIST.

SPECIFICATION REFERENCE		UNIFORM STANDARD DRAWINGS CLARK COUNTY AREA		
628	PAINTING TRAFFIC STRIPING	TYPICAL DELINEATION FOR BIKE FACILITIES 80 FT. RIGHT-OF-WAY		
633	PAVEMENT MARKERS			
		DATE 6-8-95	DWG. NO. 244.2A	PAGE NO. 50.2A

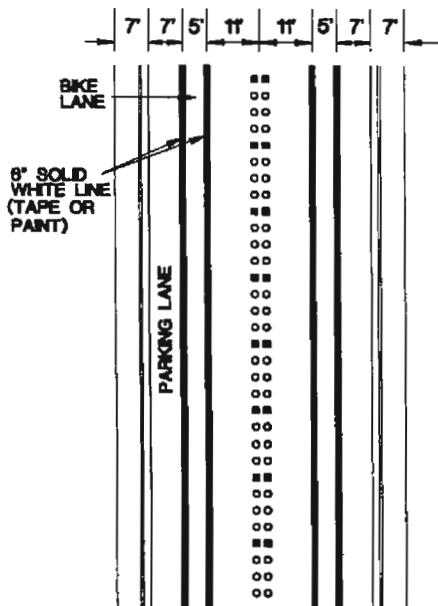

ALTERNATE A

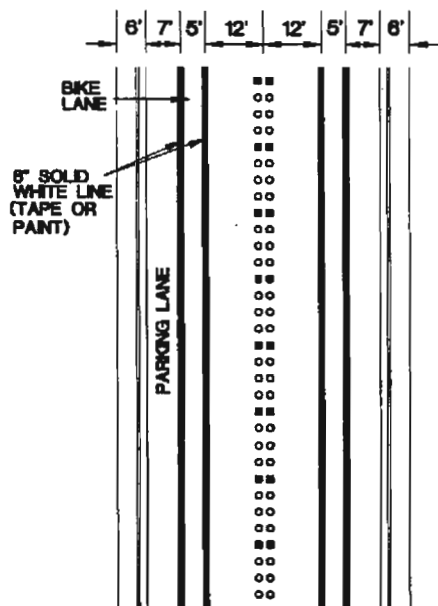

ALTERNATE B

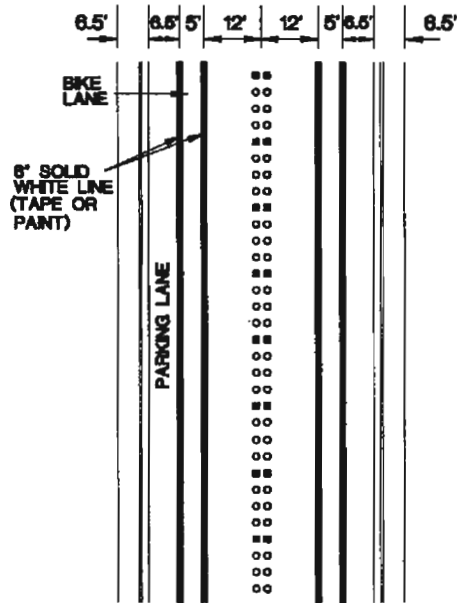

ALTERNATIVE C

NOTES:

1. LANE LINE DELINEATION SHALL COMPLY WITH STANDARD DRAWING NO. 244 & 244A.
2. BIKE LANES MUST BE A MINIMUM OF 4 FT. AND NO GREATER THAN 8 FT. WIDE; HOWEVER, A WIDTH OF 5 FT. IS PREFERRED.
3. ALL CURB LANES ARE MEASURED TO LIP OF GUTTER OR EDGE OF PAVEMENT IF CURB AND GUTTER DO NOT EXIST.

SPECIFICATION REFERENCE		UNIFORM STANDARD DRAWINGS CLARK COUNTY AREA		
628	PAINTING TRAFFIC STRIPING	TYPICAL DELINEATION FOR BIKE FACILITIES 60 FT. RIGHT-OF-WAY (PARKING ON BOTH SIDES)		
633	PAVEMENT MARKERS			
		DATE 6-8-95	DWG. NO. 244.3	PAGE NO. 50.3

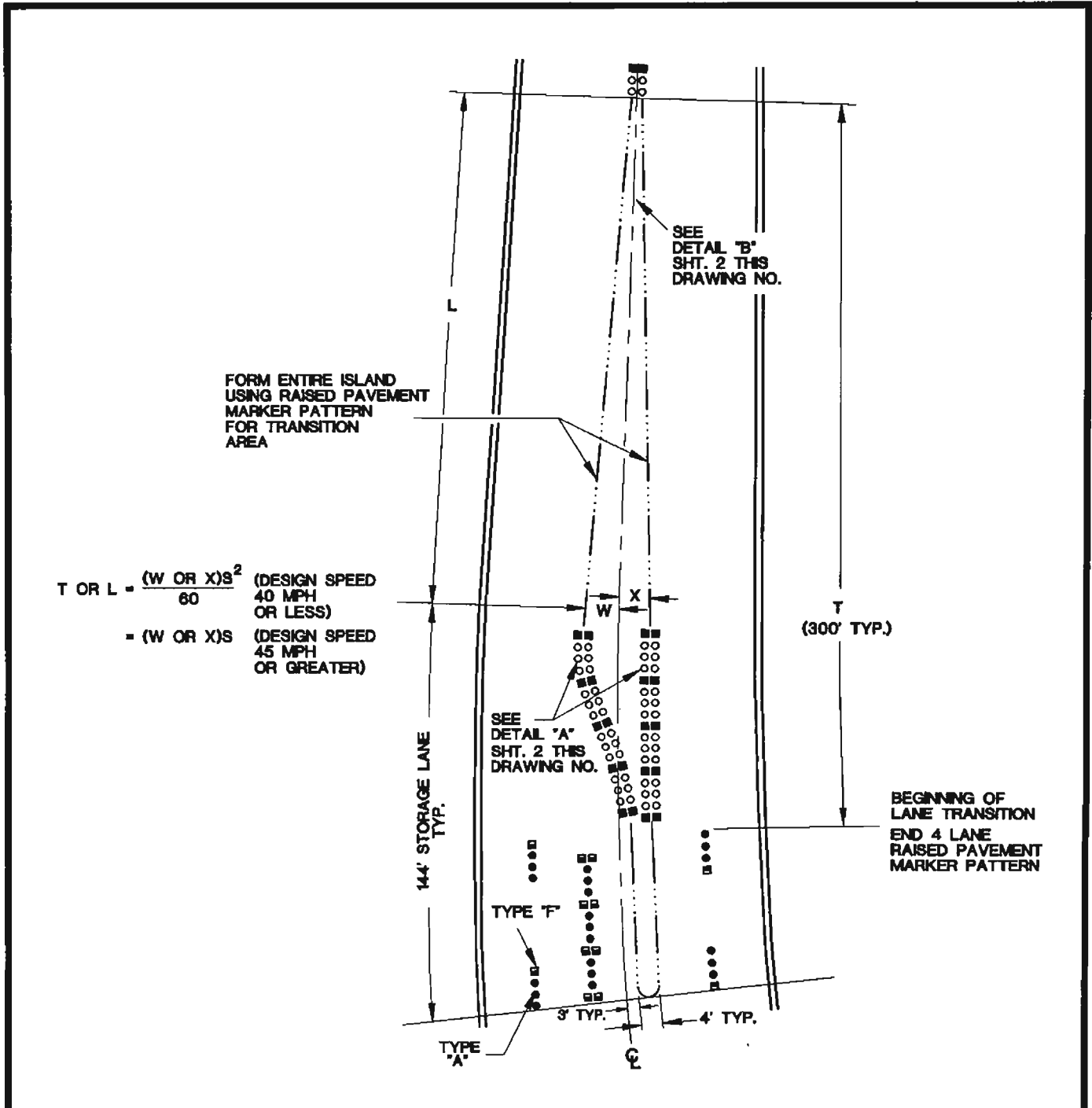

NOTE:

SEE SHEET 3 THIS DRAWING NUMBER IF PATTERN IS TO BE USED AT A GORE POINT TO DIVIDE TRAFFIC MOVING IN SAME DIRECTION.

SPECIFICATION REFERENCE		UNIFORM STANDARD DRAWINGS CLARK COUNTY AREA		
628	PAINING TRAFFIC STRIPING	TYPICAL LANE DELINEATION IN TRANSITION SECTIONS		
633	PAVEMENT MARKERS			
		DATE 6-11-93	DWG. NO. 245 (1 OF 3)	PAGE NO. 51

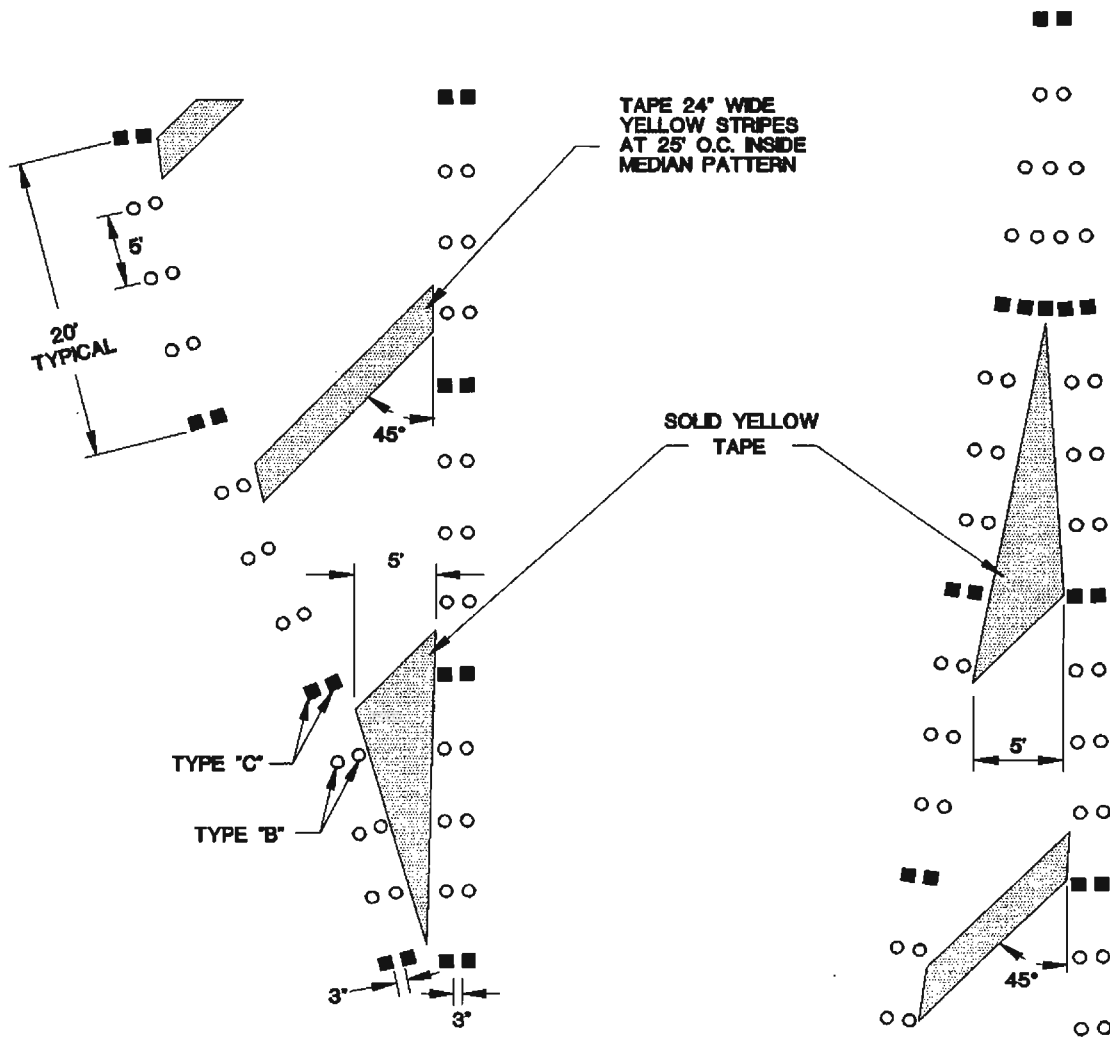

DETAIL "A"

DETAIL "B"

NOTE:

PAINT MAY BE USED IN LIEU OF TAPE AND/OR RAISED PAVEMENT MARKERS AT THE DISCRETION OF THE ENGINEER.

SPECIFICATION REFERENCE		UNIFORM STANDARD DRAWINGS CLARK COUNTY AREA	
628	PAINTING TRAFFIC STRIPING	DETAILS FOR TYPICAL LANE DELINEATION IN TRANSITION SECTIONS	
633	PAVEMENT MARKERS		
		DATE 6-11-93	DWG. NO. 245 (2 OF 3) PAGE NO. 51A

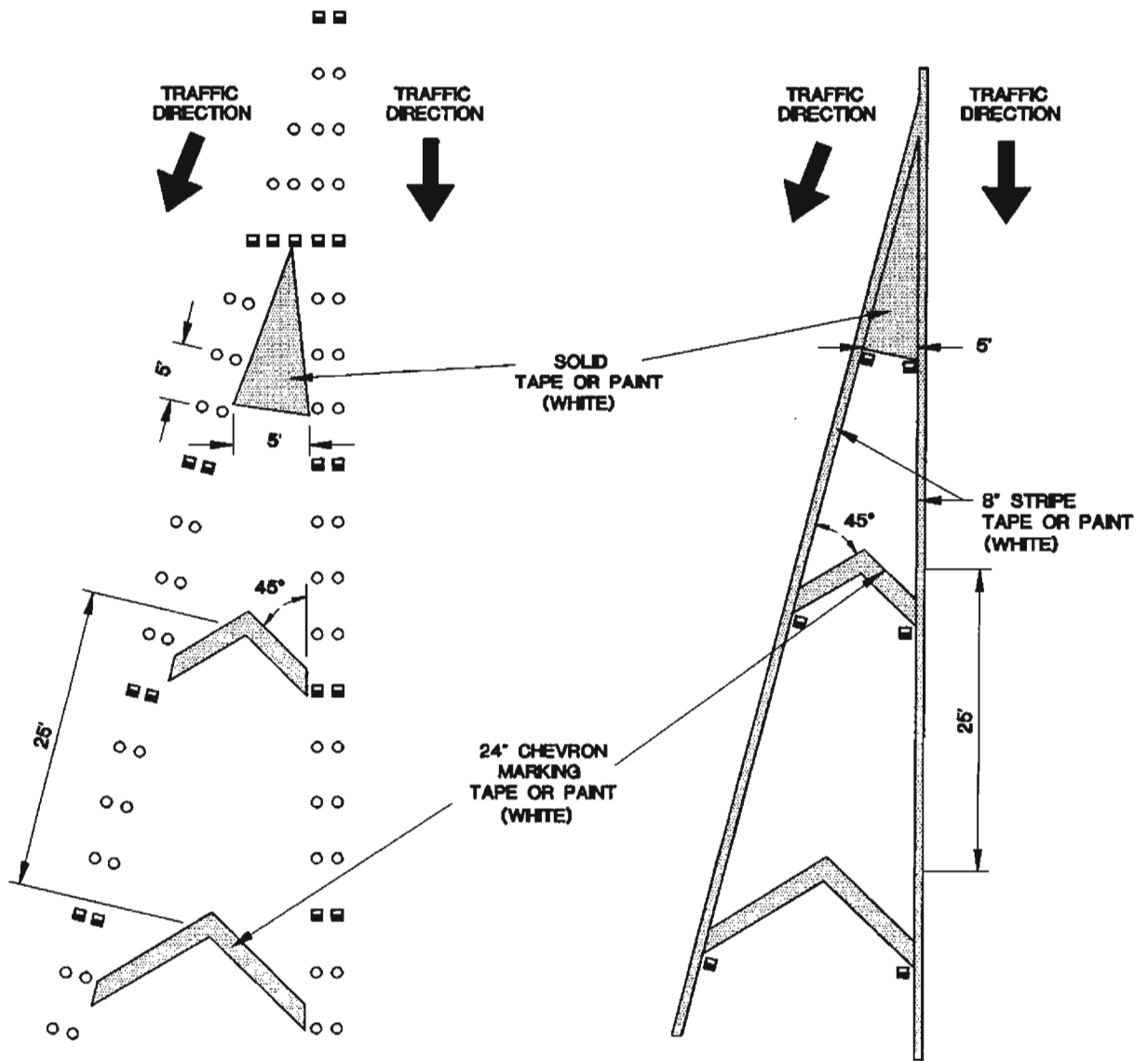

PAVEMENT MARKER DETAIL

TAPE OR PAINT DETAIL

SPECIFICATION REFERENCE		UNIFORM STANDARD DRAWINGS CLARK COUNTY AREA	
628	PAINTING TRAFFIC STRIPING	TYPICAL LANE DELINEATION IN TRANSITION SECTIONS WHERE TRAFFIC FLOW IN SAME DIRECTION	
633	PAVEMENT MARKERS		
		DATE 6-11-93	DWG. NO. 245 (3 OF 3) PAGE NO. 51B

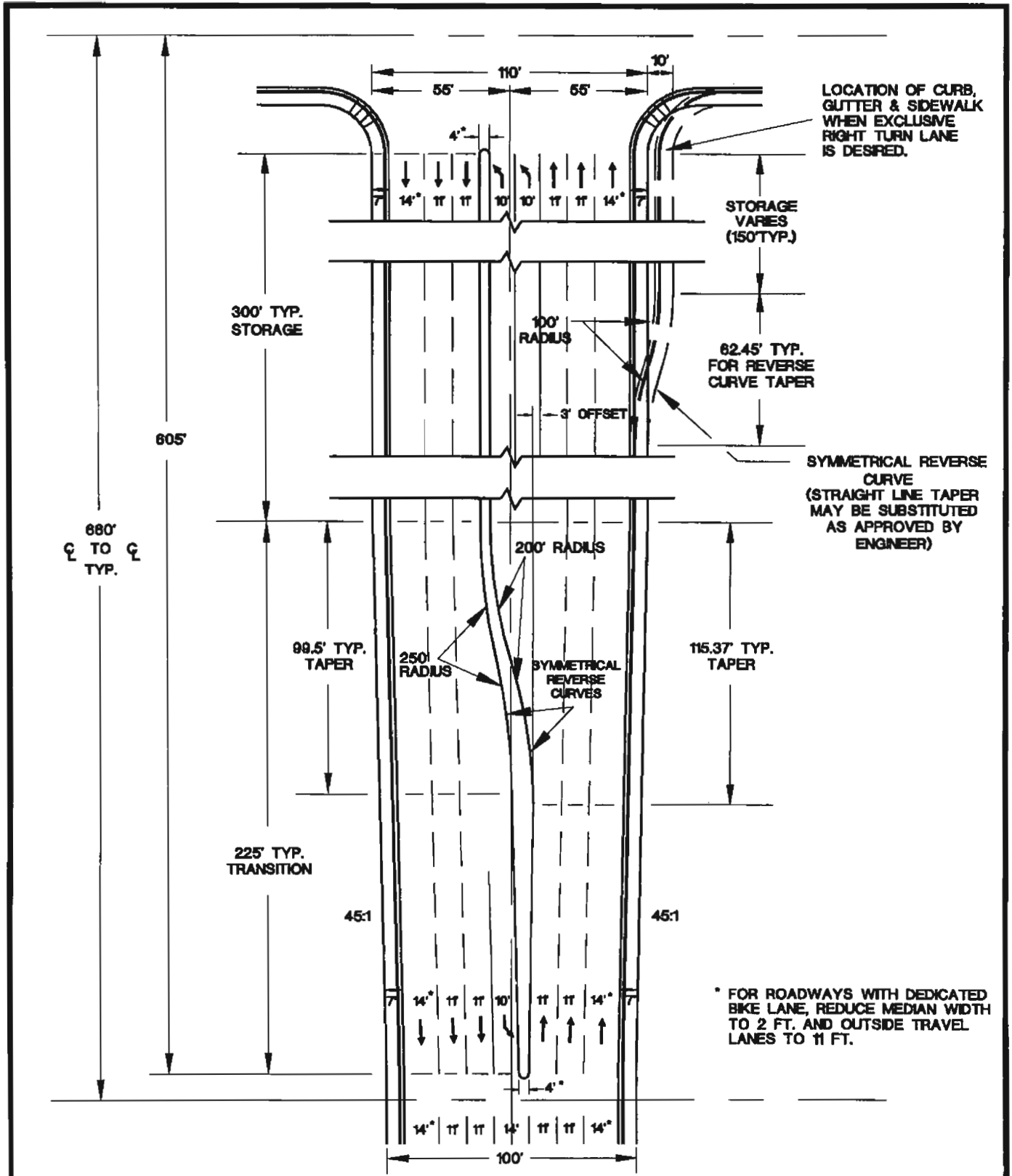

SPECIFICATION REFERENCE	

**UNIFORM STANDARD DRAWINGS
CLARK COUNTY AREA**

**TYPICAL LANE CONFIGURATION FOR
MAJOR STREET INTERSECTIONS
AND MEDIAN DETAIL
CASE I**

DATE 6-9-94	DWG. NO. 245.1 (1 OF 2)	PAGE NO. 51.1
-------------	-------------------------	---------------

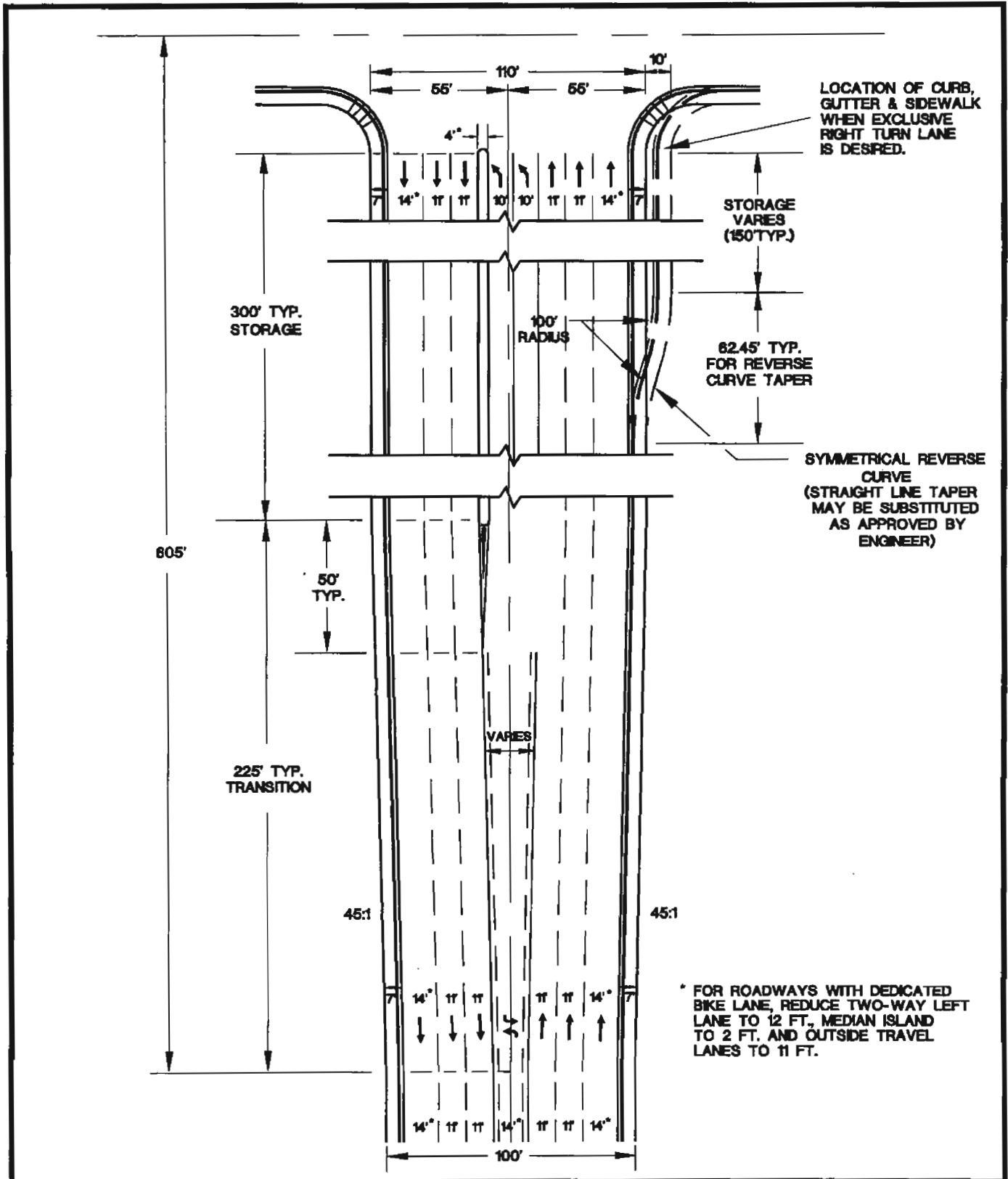

SPECIFICATION REFERENCE	

**UNIFORM STANDARD DRAWINGS
CLARK COUNTY AREA**

**TYPICAL LANE CONFIGURATION FOR
MAJOR STREET INTERSECTIONS
AND MEDIAN DETAIL
CASE II**

DATE 6-9-94 | DWG. NO. 245.1 (2 OF 2) | PAGE NO. 51.1A

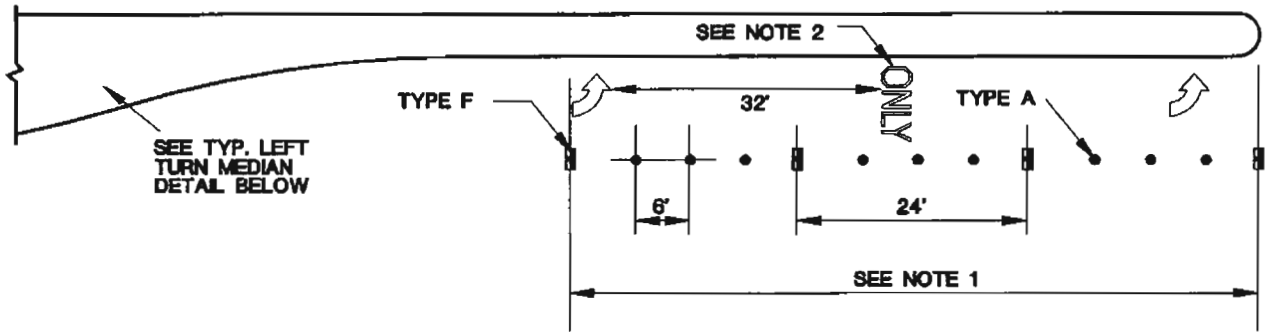

ADDED LEFT TURN LANE

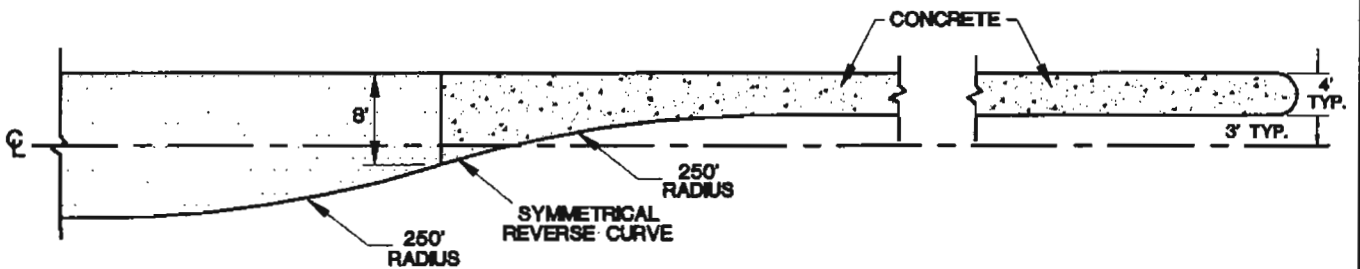

TYPICAL LEFT TURN MEDIAN DETAIL

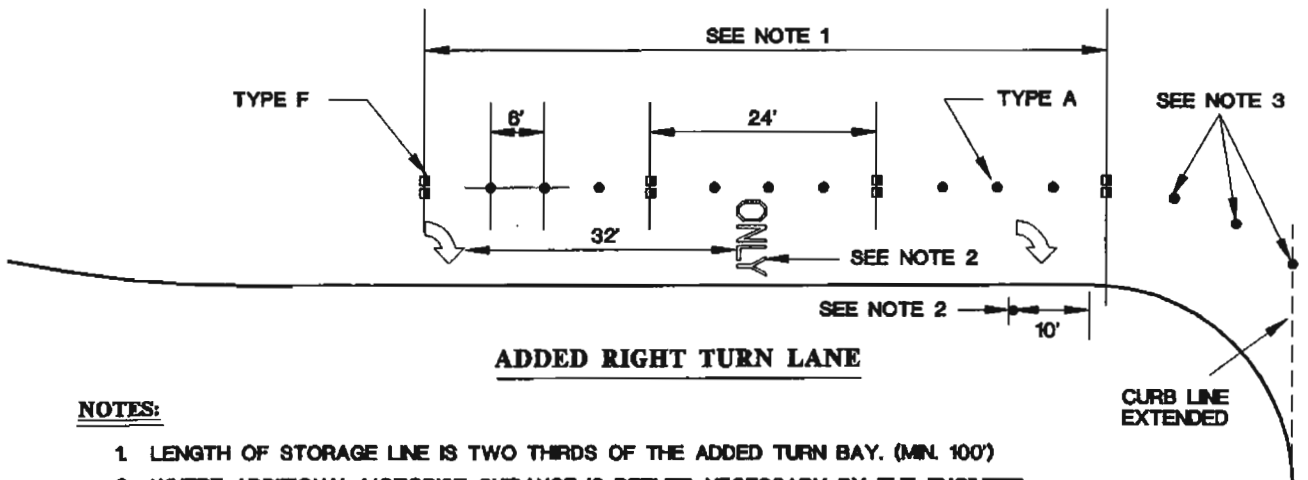

ADDED RIGHT TURN LANE

NOTES:

1. LENGTH OF STORAGE LINE IS TWO THIRDS OF THE ADDED TURN BAY. (MIN. 100')
2. WHERE ADDITIONAL MOTORIST GUIDANCE IS DEEMED NECESSARY BY THE ENGINEER, INSTALL R3-7R SIGN, ARROW SYMBOL AND "ONLY" SYMBOL PAVEMENT MARKINGS FOR THE LENGTH OF THE STORAGE LINE.
3. PAVEMENT MARKERS OR TAPE MAY BE USED FOR ADDITIONAL GUIDANCE AT THE DISCRETION OF THE ENGINEER.

SPECIFICATION REFERENCE		UNIFORM STANDARD DRAWINGS CLARK COUNTY AREA		
633	PAVEMENT MARKERS	STANDARD PAVEMENT MARKERS ADDED TURN LANE		
		DATE 8-11-93	DWG. NO. 246	PAGE NO. 52

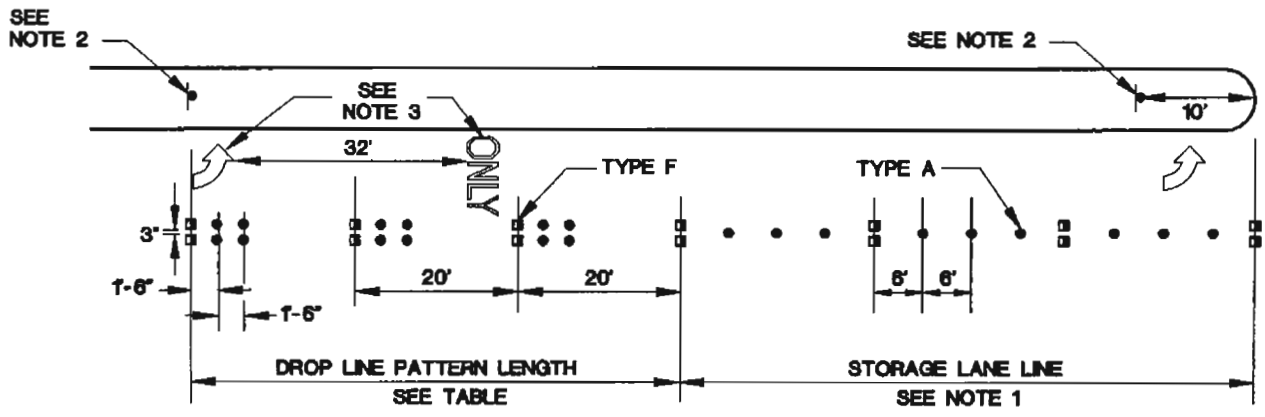

TYP. DROP LINE LENGTHS	
POSTED SPEED (MPH)	LENGTH (FT)
25	240
30	320
35	400
40	480
45	560
50	640
55	720

FORCED LEFT TURN LANE

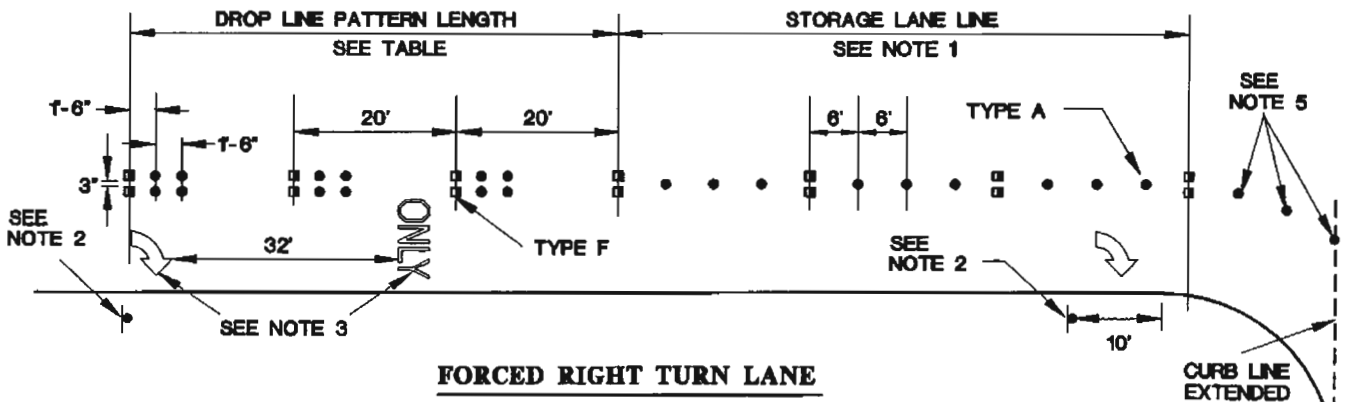

FORCED RIGHT TURN LANE

NOTES:

1. THE MINIMUM LENGTH OF STORAGE LINE IS 250 FT. ON ARTERIALS AND 150 FT. ON ALL OTHERS.
2. A MINIMUM OF 2@ R3-7R OR R3-7L SIGNS SHALL BE INSTALLED IN ADVANCE OF THE INTERSECTION AT DISTANCES APPROVED BY THE ENGINEER. RECOMMENDED LOCATIONS ARE SHOWN ABOVE.
3. ONE SET OF PAVEMENT MARKINGS CONTAINING ONE ARROW SYMBOL AND ONE "ONLY" SYMBOL SHALL BE PLACED AT THE BEGINNING OF THE DROP LANE.
4. WHERE ADDITIONAL MOTORIST GUIDANCE IS DEEMED NECESSARY BY THE ENGINEER, ADDITIONAL ARROW SYMBOL AND "ONLY" SYMBOL PAVEMENT MARKINGS AND OVERHEAD MOUNTED R3-5 SIGNS MAY BE INSTALLED.
5. PAVEMENT MARKERS OR TAPE MAY BE USED FOR ADDITIONAL GUIDANCE AT THE DISCRETION OF THE ENGINEER.

SPECIFICATION REFERENCE		UNIFORM STANDARD DRAWINGS CLARK COUNTY AREA		
633	PAVEMENT MARKERS	STANDARD PAVEMENT MARKERS FORCED TURN LANE		
		DATE 8-11-93	DWG. NO. 246A	PAGE NO. 52A

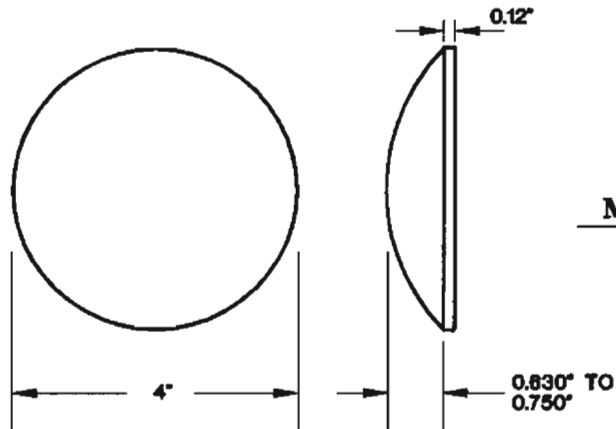

**TYPE A & B
MARKER DETAIL**
(NON-REFLECTIVE)

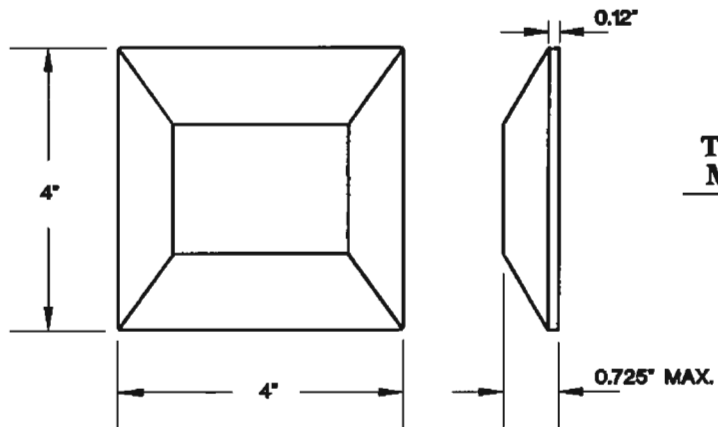

**TYPE C, D, E & F
MARKER DETAIL**
(REFLECTIVE)

LANE MARKER SCHEDULE

- TYPE A ● CIRCULAR WHITE CERAMIC MARKER
- TYPE B ○ CIRCULAR YELLOW CERAMIC MARKER
- TYPE C ■ TWO WAY YELLOW REFLECTOR
- TYPE D ▣ ONE WAY YELLOW REFLECTOR,
YELLOW TOWARD ONCOMING TRAFFIC
- TYPE E □ ONE WAY WHITE REFLECTOR,
WHITE TOWARD ONCOMING TRAFFIC
- TYPE F ▣ TWO WAY WHITE AND RED REFLECTOR,
WHITE TOWARD ONCOMING TRAFFIC

SPECIFICATION REFERENCE		UNIFORM STANDARD DRAWINGS CLARK COUNTY AREA		
633	PAVEMENT MARKERS			
		MARKER DETAILS AND LANE MARKER SCHEDULE		
		DATE 6-11-93	DWG. NO. 247	PAGE NO. 53

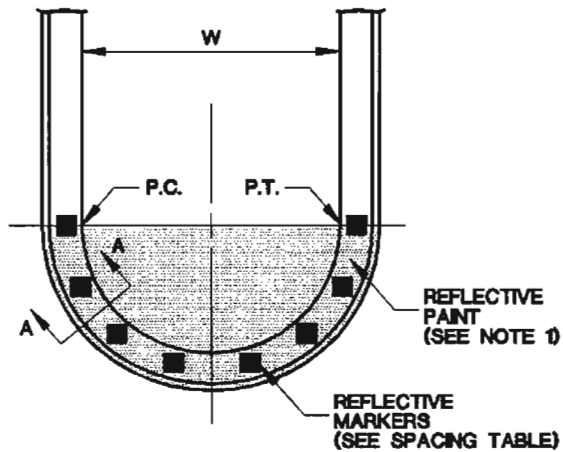

PLAN

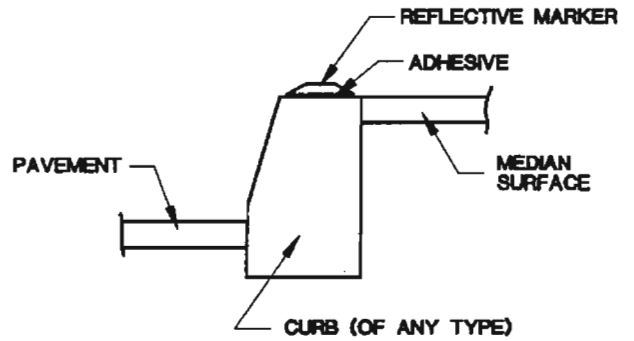

SECTION A-A

SPACING TABLE

"W"	NUMBER OF REFLECTORS PER MEDIAN NOSE *
1.0' TO 2.0'	3
2.0' TO 3.0'	4
3.0' TO 4.0'	5
4.0' & GREATER	1 EACH FOR EVERY 1.0' OF CURB LENGTH

* 1 MARKER EACH SHALL BE PLACED ON THE P.C. AND THE P.T. OF THE MEDIAN NOSE; ALL OTHERS SPACED EQUALLY BETWEEN P.T. & P.C.

NOTES:

1. ENTIRE MEDIAN SHALL BE PAINTED WITH REFLECTIVE PAINT, OF SAME COLOR AS REFLECTIVE MARKERS, FROM THE MEDIAN NOSE BACK 5 FEET OR TO THE P.C., WHICHEVER IS GREATER.
2. REFLECTIVE PAVEMENT MARKERS USED ON MEDIAN SHALL CONFORM TO STANDARD DRAWING NO. 247.
3. ORIENTATION OF THE REFLECTIVE MARKERS FACES SHALL BE MADE IN THE FIELD TO ENSURE THAT MARKERS ARE AIMED AT APPROACHING VEHICLES TO BEST ADVANTAGE, ESPECIALLY IN HORIZONTALLY CURVED ROAD SECTIONS.

SPECIFICATION REFERENCE		UNIFORM STANDARD DRAWINGS CLARK COUNTY AREA	
628	PAINTING TRAFFIC STRIPING	MEDIAN NOSE MARKINGS	
633	REFLECTIVE PAVEMENT MARKERS		
		DATE 6-11-93	DWG. NO. 248
		PAGE NO. 54	

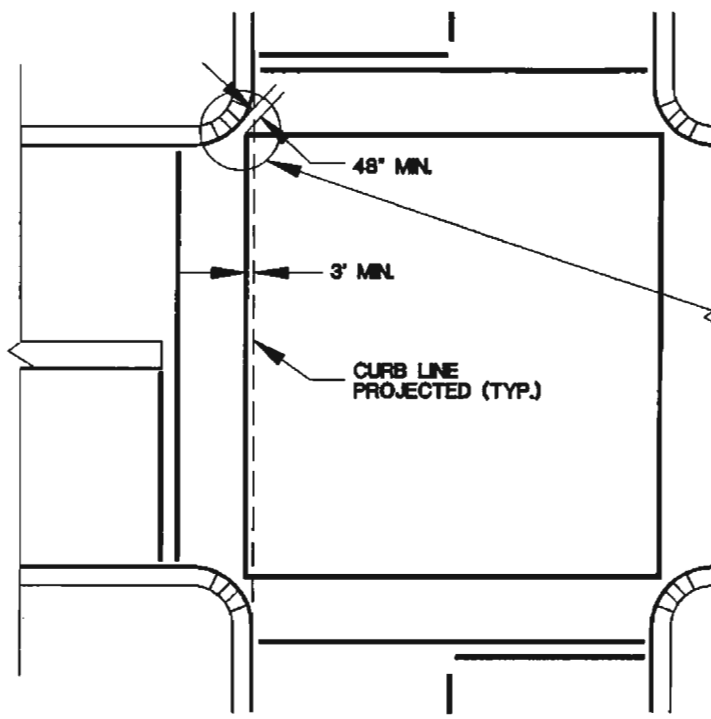

**TYPICAL MARKING
CURB RAMP IN
MIDDLE OF
CURB RETURN**

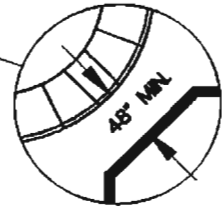

OPTIONAL DETAIL

NOTE:
USE MARKING PER
OPTIONAL DETAIL IF
NECESSARY TO OBTAIN
3' MINIMUM CLEARANCE
BETWEEN CROSSWALK
AND CURB LINE
PROJECTED.

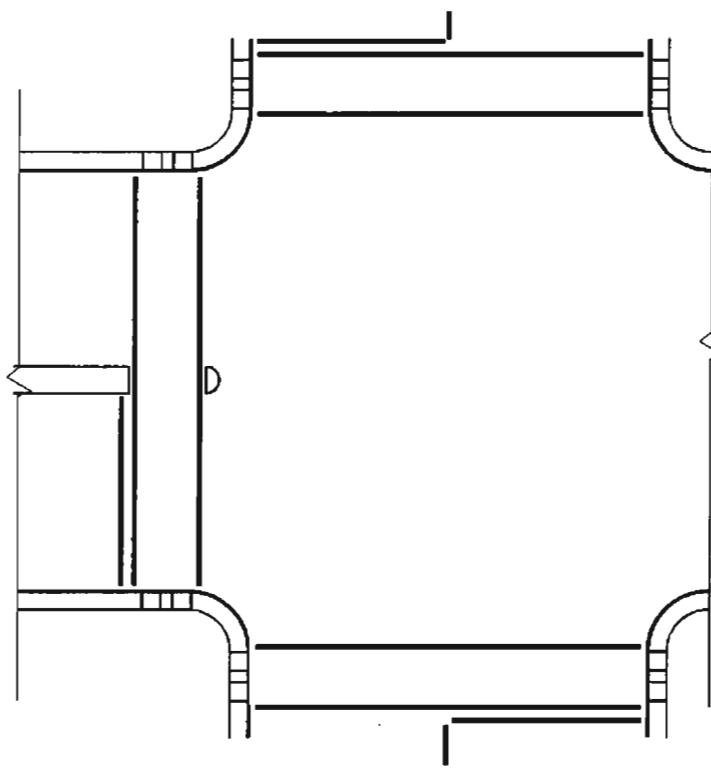

**TYPICAL MARKING
CURB RAMP
ADJOINING
CURB RETURN**

SPECIFICATION REFERENCE	

**UNIFORM STANDARD DRAWINGS
CLARK COUNTY AREA**

**CROSSWALK
MARKINGS**

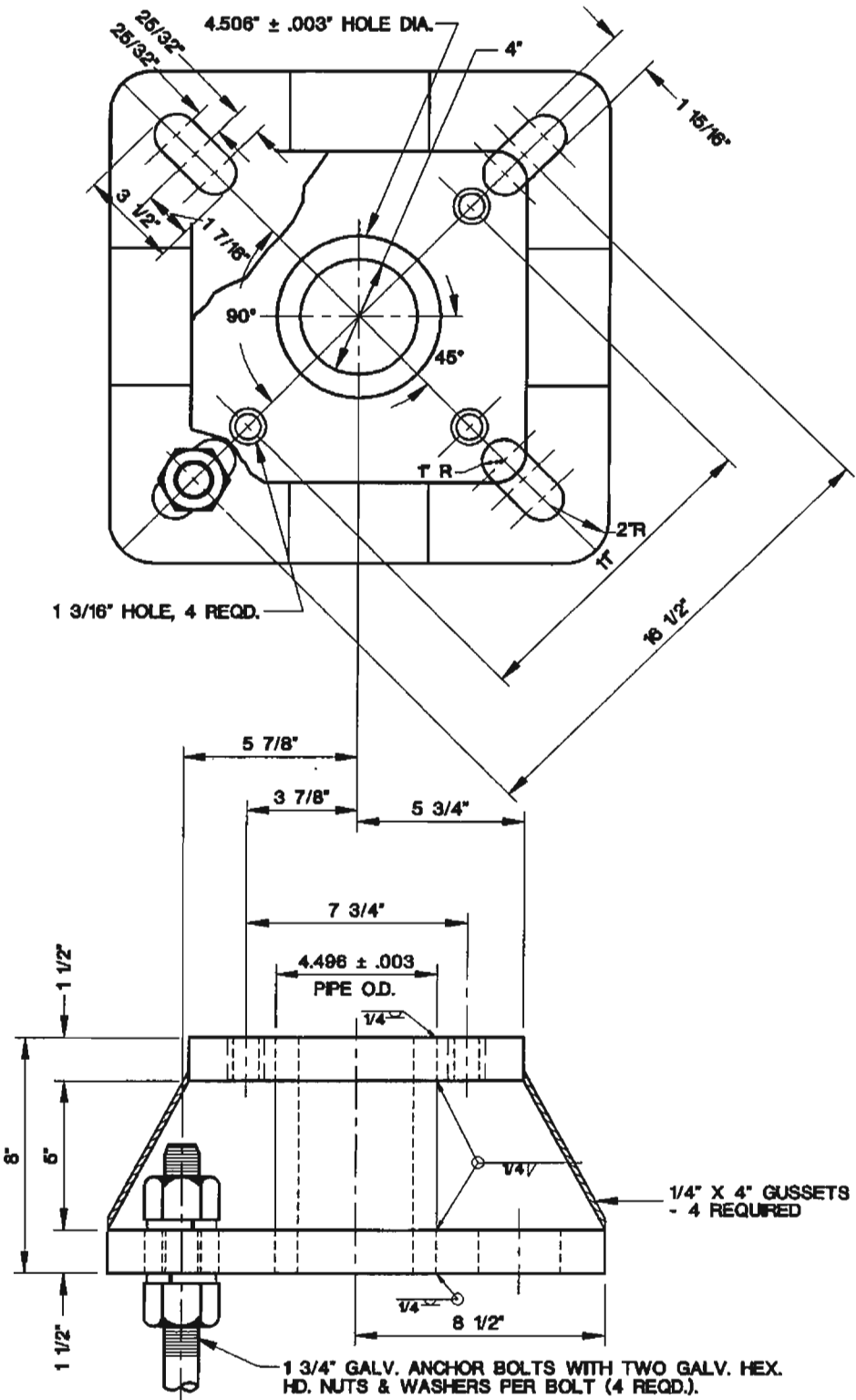

SPECIFICATION REFERENCE	

**UNIFORM STANDARD DRAWINGS
CLARK COUNTY AREA**

**BASE ADAPTOR PLATE
FOR 16-1/2" BOLT CIRCLE FOUNDATION**

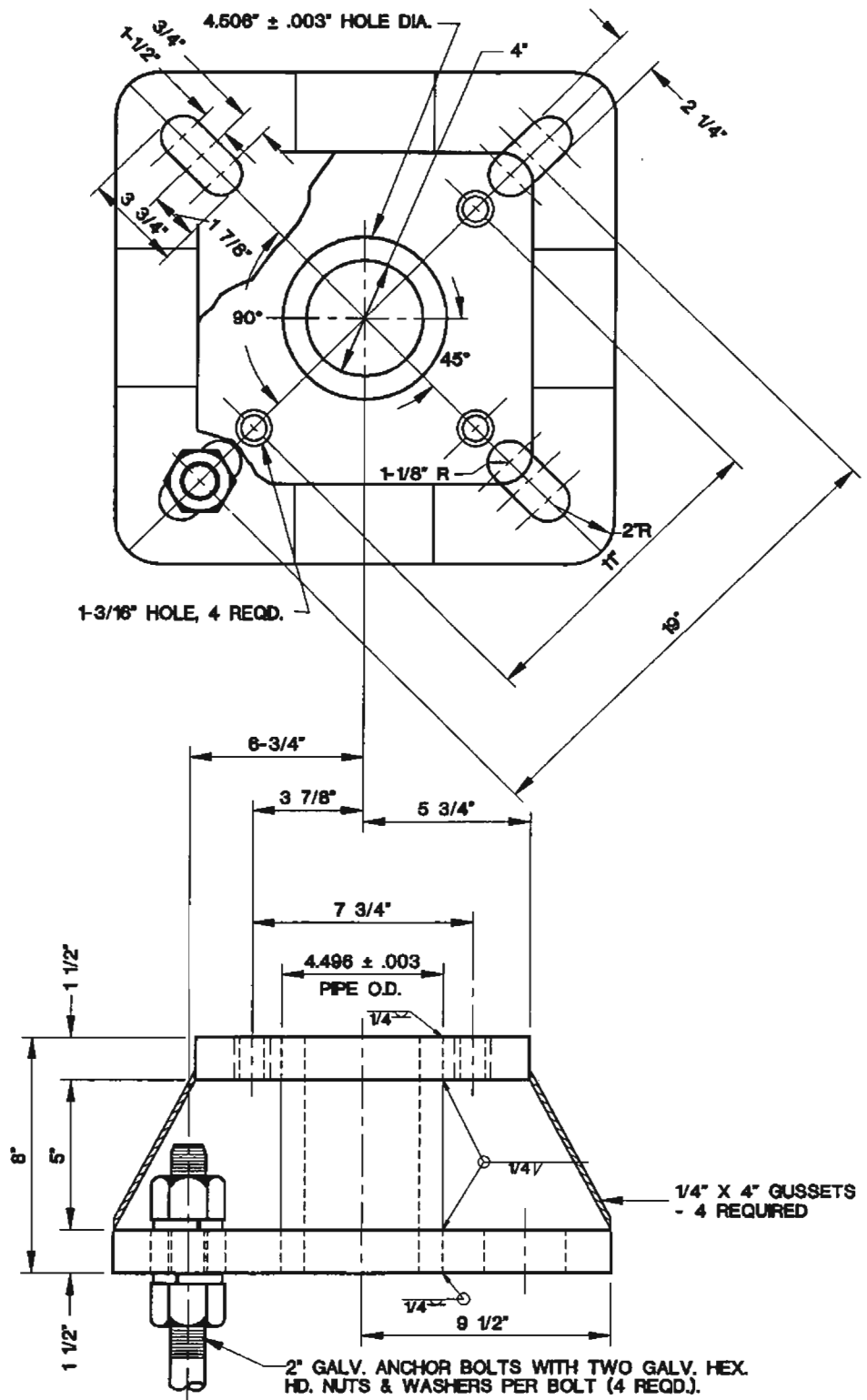

SPECIFICATION REFERENCE	

**UNIFORM STANDARD DRAWINGS
CLARK COUNTY AREA**

**BASE ADAPTOR PLATE
FOR 19" BOLT CIRCLE FOUNDATION**

DATE 2-11-93	DWG. NO. 323	PAGE NO. 82
--------------	--------------	-------------

UNIFORM STANDARD DRAWINGS, CLARK COUNTY AREA

TABLE OF CONTENTS

VOLUME I
SECTION 100
SYMBOLS AND ABBREVIATIONS

<u>DRAWING NUMBER</u>		<u>PAGE NUMBER</u>
101-104	Symbols	1-4
105-106	Abbreviations	5-6

SECTION 200
STREET IMPROVEMENTS

201	Minimum Back of Curb Radius	7
201.1	Additional Right-of-way Required at Major Intersections	7.1
202	Arterial Urban Area Street Sections (Clark County, City of Henderson, City of Boulder City and City of Mesquite)	8
203	Arterial Urban Area Street Sections (Cities of Las Vegas and North Las Vegas)	9
204	Collector Urban Area Street Sections (Clark County, City of Henderson, City of Boulder City and City of Mesquite)	10
205	Collector Urban Area Street Sections (Cities of Las Vegas and North Las Vegas)	11
206	Local Residential Urban Area Streets Sections (Clark County, City of Henderson, City of Boulder City and City of Mesquite)	12
207	Local Residential Urban Area Street Sections (Cities of Las Vegas and North Las Vegas)	13
208	Half Street Construction Sections	14
209	Access Roads	15
210	Private Street Sections	16
211	Knuckle	17
212	Cul-De-Sac	18
213	Hammerhead (Clark County and City of Mesquite Only)	19
214	Alley (Except Clark County)	20
215	Alley, Concrete (Except Clark County)	21
216	"L" Type Curb and Gutter	22
217	Roll Type Curb and Gutter Residential Area	23
217A	30" Roll Curb Residential Area	23A
218	Median Island Typical Section	24
219	"A" and "L" Type Island Curb	25
220	Tack on Island Curb	26

SECTION 200
STREET IMPROVEMENTS
CONTINUED

<u>DRAWING NUMBER</u>		<u>PAGE NUMBER</u>
221	Tack on Island (Except City of Henderson)	27
222	Residential Driveway Geometrics	28
222A	Commercial and Multi-Family Driveway Geometrics	28A
223	Residential Driveway	29
224	Commercial and Industrial Driveway (Option A)	30
225	Commercial and Industrial Driveway (Option B) or Private Street Access	31
226	Commercial and Industrial Driveway (Option B) (North Las Vegas)	32
227	Depressed Alley Driveway (City of Las Vegas)	33
228	Cross Gutter	34
229	Half Street Cross Gutter	35
230	Concrete Pavement Intersection Typical Layout	36
231	Concrete Pavement Typical Roadway Section	37
232	Concrete Pavement Construction Details	38
233	Concrete Pavement Joint Details	39
234	Sidewalk	40
234.1	Typical Bus Turnout	40.1
234.2	Bus Stop Loading Pad and Optional Sidewalk Ramp	40.2
235	Sidewalk Ramp	41-41D
236	Sidewalk Drain	42
237	Concrete Barrier Rail	43
238	Precast Bumper Block	44
239	Type I Monument	45
240	Type II Monument	46
241	Type III Monument	47
242	Type IV Monument	48
243	Typical Monument Location	49
244	Typical Centerline Delineation	50
244A	Typical Lane Line Delineation	50A
244.1	Typical Delineation for Bike Facilities 100 Ft. or Greater Right-of-way	50.1
244.1A	Typical Delineation for Bike Facilities 100 Ft. Right-of-way	50.1A
244.2	Typical Delineation for Bike Facilities 80 Ft. Right-of-way	50.2
244.2A	Typical Delineation for Bike Facilities 80 Ft. Right-of-way	50.2A
244.3	Typical Delineation for Bike Facilities 60 Ft. Right-of-way (Parking on Both Sides)	50.3

SECTION 200
STREET IMPROVEMENTS
CONTINUED

<u>DRAWING NUMBER</u>		<u>PAGE NUMBER</u>
245	Typical Lane Delineation in Transition Sections	51
	Details for Typical Lane Delineation in Transition Sections	51A
	Typical Lane Delineation in Transition Sections Where Traffic Flow in Same Direction	51B
245.1	Typical Lane Configuration for Major Street Intersections and Median Detail	51.1-51.1A
246	Standard Pavement Markers-Added Turn Lane	52
246.1	Bike Lane Signing & Striping Intersection with Exclusive Right-Turn Lane	52.1
246A	Standard Pavement Markers - Forced Turn Lane	52A
247	Marker Details and Lane Marker Schedule	53
248	Median Nose Markings	54
249	Standard Street Name Sign Post Installation	55
250	Street Name Sign Face Copy	56
251	Street Name Sign Blanks	57
252	Chain Link Fence (72" High or Less)	58
253	Chain Link Gates	59
254	Crosswalk Markings	59A

SECTION 300
STREET LIGHTING

301-306	Streetlight Locations at Intersections	60-65
307	Maximum Spacing Street Light Standards	66
308	Maximum Spacing Street Light Standards (City of Henderson)	67
309	Street Lighting Standard with 2" Pipearm	68
310	Street Lighting Standard with Double 2" Pipearm	69
311	Mast Arm Details for Tapered Single and Double Mast Arm Lighting Standards	70
312	Street Lighting Standards with Tapered Mast Arm	71
313	Street Lighting Standard with Double Tapered Mast Arm	72
314-316	Safety Base for Street Lighting Standard	73-75
317	Foundation for a 7 or 11 Gage Lighting Standard in an Open Area	76
318	Foundation for a 7 or 11 Gage Lighting Standard in Back Portion of Sidewalk	77
319	Foundation for a 7 or 11 Gage Lighting Standard Behind Sidewalk	78
320	Modified Existing Street Light Foundation for Installation of Underground Conduit	79
321	Type "H" Foundation	80

SECTION 300
STREET LIGHTING
CONTINUED

<u>DRAWING NUMBER</u>		<u>PAGE NUMBER</u>
322	Base Adaptor Plate for 16-1/2" Bolt Circle Foundation	81
323	Base Adaptor Plate for 19" Bolt Circle Foundation	82
324	Service Point on Wooden Pole	83
325	Street Lighting Service Point Located on the First Standard	84
326	240 Volt 2 Wire Wiring Diagram for Pole Mount Service Point	85
327	240 Volt 2 Wire Wiring Diagram for Padmount Service Point	86
328	Service Point Single Meter Padmount	87
329	Foundation for Single Meter Padmount Service Pedestal	88
330	Lighting Standard Wiring Diagram, 240 Volt, 3 Wire Underground System	89
331	Twin Lighting Standard Wiring Diagram, 240 Volt, 2 Wire Underground System	90
332	120 Volt, 1 Phase, 3 Wire Wiring Diagram for Pole Mount Service Point	91
333	Lighting Standard Wiring Diagram, 120 Volt, 1 Phase, 3 Wire Multiple Underground System	92
334	Overhead Double Conductor Connection for Series Street Lighting System	93
335	Overhead Single Conductor Connection for Series Street Lighting System	94
336	Concrete Around Pull boxes in Areas with no Sidewalk	95
337	No. 3-1/2" Pull Box	96
338	No. 5 Pull Box	97
339	No. 7 Pull Box	98
340	Steel Pull Box Cover	99
341	Utility Pull Box Locations, Sidewalk and Driveway	100

SECTION 400
DRAINAGE IMPROVEMENTS

401-402	Storm Drain Manholes General Notes	101-102
403	Type I Manhole	103
404	Type IA Manhole	104
405	Type II Manhole	105
406	Type III Manhole	106
407	Precast Manhole Tees	107
408	Concrete Collar Around Manholes	108
409	Standard Manhole Cover and Ring	109

SECTION 400
DRAINAGE IMPROVEMENTS
CONTINUED

<u>DRAWING NUMBER</u>		<u>PAGE NUMBER</u>
410	Standard Manhole Steps	110
411	Drop Inlet Type "A"	111
412	Drop Inlet Type "B" (Except Clark County)	112
413	Drop Inlet Type "C"	113
414	Drop Inlet Type "D"	114
415	Drop Inlet Types "A" and "B" Special Design	115
416	Beehive Drop Inlet	116
417	Drop Inlet Frame and Grate	117
418	Drop Inlet Steel Plate Anchorage	118
419	Drop Inlet Steel Plate and Protection Bar	119
420	Typical Open Channel	120

SECTION 500
UTILITIES AND MISCELLANEOUS IMPROVEMENTS

501	Typical Underground Utility Locations in Street	121
502	Trench Backfill Unpaved Areas	122
503	Granular Trench Backfill Paved Areas (Streets with 60' or Less R/W)	123
504	Slurry Cement Trench Backfill Paved Areas (Streets Greater than 60' R/W)	124
505	Pipe Trench Bedding Methods	125
506	Service Installation, 5/8", 3/4", and 1" Meter Sizes-Improved Area	126
507	Service Installation, 5/8", 3/4", and 1" Meter Sizes-Unimproved Area	127
508	Service Installation, Dual 5/8", 3/4", and 1" Meter Sizes-Improved Area	128
509	Service Installation, Dual 5/8", 3/4", and 1" Meter Sizes-Unimproved Area	129
510	Service Installation, 1-1/2" and 2" Meter Sizes-Improved Area	130
511	Service Installation, 1-1/2" and 2" Meter Sizes-Unimproved Area	131
512	Thrust Block Details	132
513	Anchor Block Details Reducer or Valve	133
514	Blow - Off Assembly Locations	134
515	Blow - Off Assembly 4", 6", 8", and 10" Mains	135
516	Fire Hydrant Installation	136
517	Valve Box Installation and Adjustment	137
518	Chlorination Requirements	138