

COVER

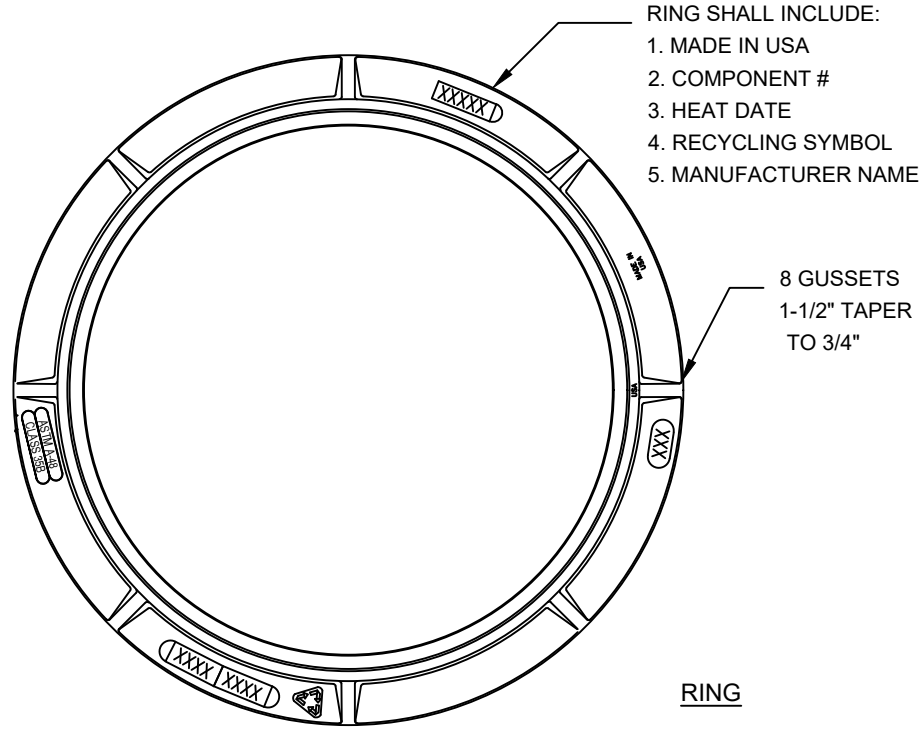

RING

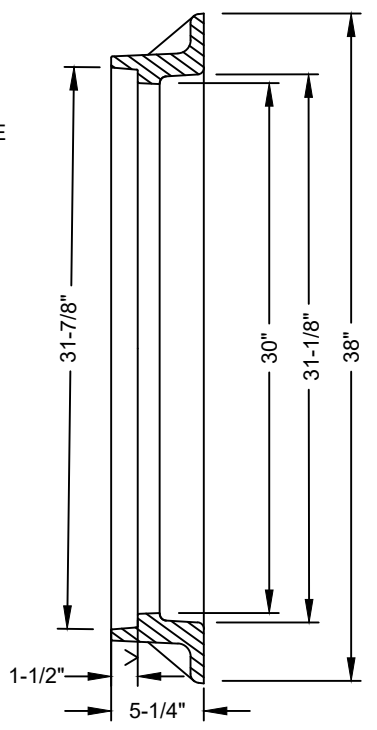

NOTES

1. RING AND COVER TO BE USA FOUNDRY NEENAH DF-1296 IN ACCORDANCE WITH ASTM A-48, CLASS 35B, OR APPROVED EQUAL.
2. CAST IRON SHALL HAVE MINIMUM TENSILE STRENGTH OF 35,000 P.S.I.
3. RING AND COVER MACHINED TO FIT.
4. WEIGHT OF RING 147 LBS. MINIMUM.
5. WEIGHT OF COVER 180 LBS. MINIMUM.
6. THE USE OF A 30\"/>

		AGENCY APPROVED	B	C	H	L	M	N	R
SPECIFICATION REFERENCE		UNIFORM STANDARD DRAWINGS CLARK COUNTY AREA							
712	MISCELLANEOUS METALS								
		STANDARD MANHOLE 30 INCH COVER AND RING							
		DATE 01-09-25	DWG. NO. 409.1						